

# Light Fidelity (Li-Fi) A Prototype Li-Fi System to Transfer Data Through Wireless Communication.

Siddhi Narvekar<sup>1</sup> Sukanya Sathe<sup>2</sup> Sayli Pawar<sup>3</sup> Shruti Mhapsekar<sup>4</sup> Prof. Varun Mishra<sup>5</sup>

<sup>1,2,3,4</sup>Students <sup>5</sup>Assistant Professor

<sup>1,2,3,4,5</sup>Department of Electronics and Telecommunication Engineering

<sup>1,2,3,4,5</sup>Atharva College Of Engineering, Mumbai - 400095, Maharashtra, India, University of Mumbai.

*Abstract*— The radio spectrum is highly congested and the demand for wireless data is much worse. Requirement of bandwidth for RF communication is rapidly exhausted. In the present day more bandwidth is found but it's clearly not enough. Using visible light for data transmission entails many advantages and eliminates drawbacks of transmission via electromagnetic waves outside the spectrum. Visible light communication (VLC) is a data communications medium which uses visible light between 400 and 800 THz (wavelength between 780–375 nm). Visible Light Communication (VLC) is a safe technology if the sender intends to transmit confidential data. LI-FI (light fidelity) aims to build a system which carries out communication using visible light that are employed for indoor illuminations. LI-FI (light fidelity) uses the concept of Visible light communication (VLC) or can be consider as Visible Light Communication (VLC) application. In this project, prototype LI-FI (light fidelity) system for PC to PC text message transfer using Visible Light Communication (VLC) is designed. The project is to establish the communication between any two PC's using a simple circuit consisting of led in the transmitter side and the photodiode in the receiver side and the communication protocol using visible light.

**Key words:** Li-Fi, VLC,

## I. INTRODUCTION

Light Emitting Diodes are set to penetrate many areas of everyday life. An interesting property of these devices in addition to their lightening capabilities is that they can also be utilized for data transmissions as well. The project aims to build a system which carries out communication using visible light that are employed for indoor illuminations.

We have designed a prototype LI-FI system to transfer text message. The same method can be used to transfer other files. Our idea is to send data as serial data using UART serial communication from one PC to another PC using VLC. The visible light communication is used at the transmitting ends and also for reception photodiodes are used at the receiving PC. Photo diode transistor is used to recover the data from visible light and inverting amplifier is used to get the data and processed by the controller connected to PC serial communication port. The project is mainly focused to develop an alternative to short range RF communication with high speed data transfer capability. This network has its application in a large organization such as hospitals, shopping malls, schools, colleges, libraries, etc. We have developed an application that uses VLC, which enables transferring data between two devices. This paper gives overall view of the basic LI-FI system prototype design to transfer text messages through wireless visible light communication and related applications in various fields & social environments. LI-FI can be considered a future technology.

## II. WORKING PRINCIPLE

LI-FI (light fidelity) works on the principle of visible light communication (VLC). Visible light communication (VLC) is a data communications medium which uses visible light between 400 and 800 THz (wavelength between 780–375 nm). Visible light communication used visible light range (wavelength between 780–375 nm) for data communication through an LED at transmitter end. At transmitter side mechanical data like audio, video, text message, files, etc. is converted to electrical signal and then LED converts electrical data to visible optical signal and send to the receiver. At receiver photo diodes are used to receive visible light signals. At receiver side these optical signals are recovered in original form. We have designed a prototype LI-FI system to transfer text message.

### III. BLOCK DIAGRAM

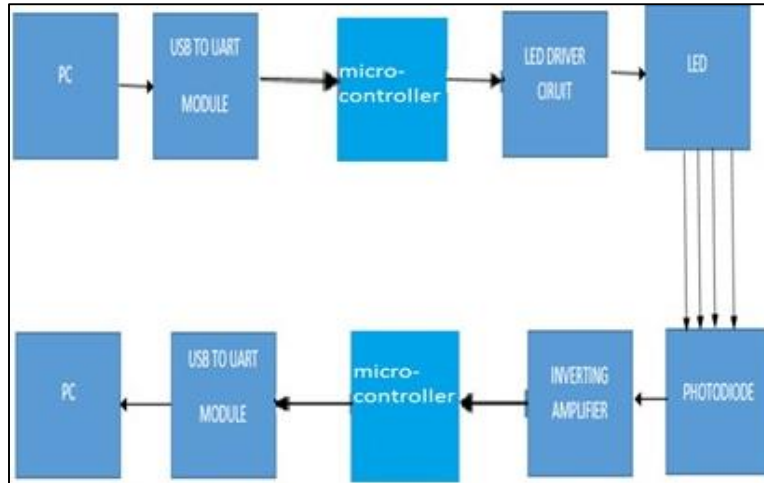

### IV. EXISTING SYSTEM

At the present time the short range communications presently involves technologies such as Bluetooth, Wi-Fi, RFID, Zigbee wireless technology, etc. Current wireless phones include 3 and 4G networks, Bluetooth and Wi-Fi technologies. Bluetooth and Wi-Fi provide short range point-to-point data transfer. These wireless technologies may choose to utilize some of the various encryption technologies available for data safety and confidentiality. Therefore these systems are too difficult to design.

### V. PROPOSED SYSTEM

We have designed a prototype LI-FI system to transfer text message. The same method can be used to transfer other files. Our idea is to send data as serial data using UART serial communication from one PC to another PC using VLC. The visible light communication is used at the transmitting ends and also for reception photodiodes are used at the receiving PC. Photo diode transistor is used to recover the data from visible light and inverting amplifier is used to get the data and processed by the controller connected to PC serial communication port.

### VI. BLOCK DIAGRAM DESCRIPTION

#### A. Led:

A light-emitting diode (LED) is a two-lead semiconductor light source. It is a p-n junction diode, which emits light when activated. When a suitable voltage is applied to the leads, electrons are able to recombine with electron holes within the device, releasing energy in the form of photons. This effect is called electroluminescence, and the color of the light (corresponding to the energy of the photon) is determined by the energy band gap of the semiconductor.

### VII. POWER SUPPLY

Power supply is a reference to a source of electrical power. A device or system that supplies electrical or other types of energy to an output load or group of loads is called a power supply unit or PSU. The term is most commonly applied to electrical energy supplies, less often to mechanical ones, and rarely to others.

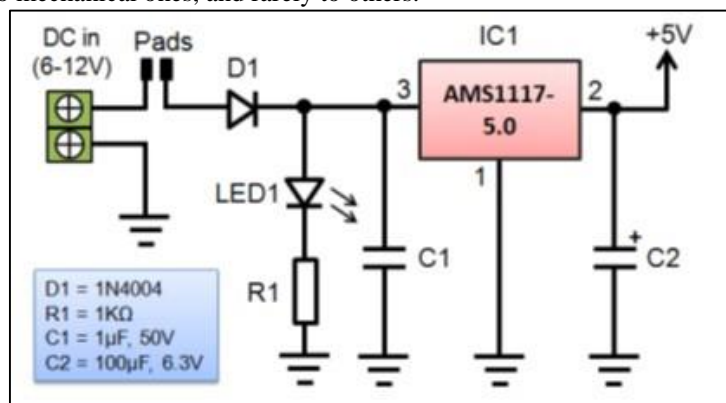

Supply will be given to this device from a battery. The reason why we will not be going for supply from a 230V mains supply because, this device will be used on the body of the human being. As the person using it in a few cases might be physically disabled, even if by any chance there is short circuit, the person will not be in a position to move away from the danger. That is the reason we prefer to use a battery in our system. We use a voltage regulator because, the embedded system works at 5V and

we don't have a 5V battery available in the market. Anything less than 5V, my system will not work, anything more than 5V, my system will get damaged.

A voltage regulator is used over here rather than a zener diode circuit or a potential divider circuit using resistors which are cost effective. The reason is because the latter two circuits are used in applications where there is fixed power (from the mains). We can't use the latter two circuits on batteries because, the voltage across the battery will reduce gradually over time. We are using an LDO (low drop out voltage) i.e., AMS1117 rather than the traditional 7805 of the difference in the drop out voltage. The drop out voltage of 7805 is 2.5V and the drop out voltage of AMS1117 is 1V. Which means that I can use a battery (for example a 9V battery) from 9V to 7.5V in a 7805 and after which even if I use the battery, the output voltage will be less than 5V. If I am using AMS1117, I can use a battery from 9V to 6V after which even if I use the battery, the output voltage will be less than 5V. The AMS1117 helps me in using the same battery for a longer duration.

On top of that, AMS1117 is low in cost and has got a lesser PCB footprint.

### VIII. TRANSMITTER

Light source can theoretically be used as transmitting device for VLC. However, some are better suited than others. For instance, incandescent lights quickly break down when switched on and off frequently. These are thus not recommended as VLC transmitters. More promising alternatives are fluorescent lights and LEDs. VLC transmitters are usually also used for providing illumination of the rooms in which they are used. This makes fluorescent lights a particularly popular choice, because they can flicker quickly enough to transmit a meaningful amount of data and are already widely used for illumination purposes. VLC will probably not be used for massive data transmission. High data rates as the ones referred to above, were reached under meticulous setups which cannot be expected to be reproduced in real-life scenarios. One can expect to see data rates of about 5 k bit/s in average applications, such as location estimation. The block diagram shown in fig 1 the distance in which VLC can be expected to be reasonably used ranges up to about 6 meters.

### IX. MICROCONTROLLER

Microcontrollers as the name suggests are small controllers. They are like single chip computers that are often embedded into other systems to function as processing/controlling unit. For example the remote control you are using probably has microcontrollers inside that do decoding and other controlling functions. They are also used in automobiles, washing machines, microwave ovens, toys ... etc, where automation is needed. Micro-controllers are useful to the extent that they communicate with other devices, such as sensors, motors, switches, keypads, displays, memory and even other micro-controllers. Many interface methods have been developed over the years to solve the complex problem of balancing circuit design criteria such as features, cost, size, weight, power consumption, reliability, availability, manufacturability. Many microcontroller designs typically mix multiple interfacing methods. In a very simplistic form, a micro-controller system can be viewed as a system that reads from (monitors) inputs, performs processing and writes to (controls) outputs. Embedded system means the processor is embedded into the required application. An embedded product uses a microprocessor or microcontroller to do one task only. In an embedded system, there is only one application software that is typically burned into ROM. Example: printer, keyboard, video game player.

Microprocessor - A single chip that contains the CPU or most of the computer

Microcontroller - A single chip used to control other devices

Microcontroller differs from a microprocessor in many ways. First and the most important is its functionality. In order for a microprocessor to be used, other components such as memory, or components for receiving and sending data must be added to it. In short that means that microprocessor is the very heart of the computer. On the other hand, microcontroller is designed to be all of that in one.

The microcontroller we are using over here is ATmega8. An 8 bit RISC architecture controller. The reason we are using ATmega8 is because of the architecture, low cost and the best of all is that it is open source.

#### A. Features:

- High-performance, Low-power AVR® 8-bit Microcontroller
- Advanced RISC Architecture
- 130 Powerful Instructions – Most Single-clock Cycle Execution
- 32 x 8 General Purpose Working Registers
- Fully Static Operation
- Up to 16 MIPS Throughput at 16 MHz
- On-chip 2-cycle Multiplier
- High Endurance Non-volatile Memory segments
- 8K Bytes of In-System Self-programmable Flash program memory
- 512 Bytes EEPROM
- 1K Byte Internal SRAM
- Write/Erase Cycles: 10,000 Flash/100,000 EEPROM (1)(3)
- Data retention: 20 years at 85°C/100 years at 25°C (2)(3)
- Optional Boot Code Section with Independent Lock Bits

- --In-System Programming by On-chip Boot Program
- --True Read-While-Write Operation
- Programming Lock for Software Security
- Peripheral Features
- Two 8-bit Timer/Counters with Separate Prescaler, one Compare Mode
- One 16-bit Timer/Counter with Separate Prescaler, Compare Mode, and Capture Mode
- Real Time Counter with Separate Oscillator.

#### Three PWM Channels

- 8-channel ADC in TQFP and QFN/MLF package
- --Eight Channels 10-bit Accuracy
- 6-channel ADC in PDIP package
- --Six Channels 10-bit Accuracy
- Byte-oriented Two-wire Serial Interface
- Programmable Serial USART
- Master/Slave SPI Serial Interface
- Programmable Watchdog Timer with Separate On-chip Oscillator
- On-chip Analog Comparator
- Special Microcontroller Features
- Power-on Reset and Programmable Brown-out Detection
- Internal Calibrated RC Oscillator
- External and Internal Interrupt Sources
- Five Sleep Modes: Idle, ADC Noise Reduction, Power-save, Power-down, and Standby
- I/O and Packages
- 23 Programmable I/O Lines
- 28-lead PDIP, 32-lead TQFP, and 32-pad QFN/MLF
- Operating Voltages
- 2.7 - 5.5V (ATmega8L)
- 4.5 - 5.5V (ATmega8)
- Speed Grades
- 0 - 8 MHz (ATmega8L)
- 0 - 16 MHz (ATmega8)
- Power Consumption at 4 Mhz, 3V, 25°C
- Active: 3.6 mA
- Idle Mode: 1.0 mA
- □□– Power-down Mode: 0.5 μA.

### **X. THE UART: WHAT IT IS AND HOW IT WORKS**

The Universal Asynchronous Receiver/Transmitter (UART) controller is the key component of the serial communications subsystem of a computer. The UART takes bytes of data and transmits the individual bits in a sequential fashion. At the destination, a second UART re-assembles the bits into complete bytes.

Serial transmission is commonly used with modems and for non-networked communication between computers, terminals and other devices.

There are two primary forms of serial transmission: Synchronous and Asynchronous. Depending on the modes that are supported by the hardware, the name of the communication sub-system will usually include if it supports Asynchronous communications and if it supports Synchronous communications.

Both forms are described below.

Some common acronyms are:

UART Universal Asynchronous Receiver/Transmitter

USART Universal Synchronous-Asynchronous Receiver/Transmitter

### **XI. PHOTODIODE**

A photodiode is a semiconductor device that converts light into current. The current is generated when photons are absorbed in the photodiode. A small amount of current is also produced when no light is present. Photodiodes may contain optical filters, built-in lenses, and may have large or small surface areas. Photodiodes usually have a slower response time as their surface area increases.

## **XII. INVERTING AMPLIFIER**

The inverting amplifier using an op-amp is one of the most widely used operational amplifier circuits especially as it can be used as a summing amplifier or virtual earth mixer.

As the open loop DC gain of an Operational Amplifier is extremely high we can therefore afford to lose some of this high gain by connecting a suitable resistor across the amplifier from the output terminal back to the inverting input terminal to both reduce and control the overall gain of the amplifier. This then produces an effect known commonly as Negative Feedback, and thus produces a very stable Operational Amplifier based system.

Negative Feedback is the process of “feeding back” a fraction of the output signal back to the input, but to make the feedback negative, we must feed it back to the negative or “inverting input” terminal of the op-amp using an external Feedback Resistor called  $R_f$ . This feedback connection between the output and the inverting input terminal forces the differential input voltage towards zero.

This effect produces a closed loop circuit to the amplifier resulting in the gain of the amplifier now being called its Closed-loop Gain. Then a closed-loop inverting amplifier uses negative feedback to accurately control the overall gain of the amplifier, but at a cost in the reduction of the amplifiers gain.

This negative feedback results in the inverting input terminal having a different signal on it than the actual input voltage as it will be the sum of the input voltage plus the negative feedback voltage giving it the label or term of a Summing Point. We must therefore separate the real input signal from the inverting input by using an Input Resistor,  $R_{in}$ .

As we are not using the positive non-inverting input this is connected to a common ground or zero voltage terminal as shown below, but the effect of this closed loop feedback circuit results in the voltage potential at the inverting input being equal to that at the non-inverting input producing a Virtual Earth summing point because it will be at the same potential as the grounded reference input. In other words, the op-amp becomes a “differential amplifier”.

## **XIII. FUTURE SCOPE**

- Range of operation can be extended over long distance.
- Every bulb can act as a Li-Fi hotspot.
- The enabling of the Internet-of-Things (100 times more devices).

## **XIV. BENEFITS**

The avoidance of the radio frequency spectrum crunch (10,000 times more capacity). Enabling very high peak data rates (10 Gbps). Significantly enhanced secure wireless communication (reduced interception of signals). Complete elimination of health concerns.

## **XV. APPLICATION**

- On ocean beds.
- RF restricted environment.
- Hospitals.
- In aircraft cabins.
- Street lamps.

## **XVI. ADVANTAGES**

- Achieve high speed data.
- Wireless communication.
- Low cost.
- Eliminates drawbacks of transmission via electromagnetic waves outside the spectrum.
- High security.
- Reliable.
- Easy to use.
- Not harmful to human body.

## **XVII. DISADVANTAGES**

Light can't pass through objects.

## **XVIII. CONCLUSION**

The Idea of Li-Fi technology currently attracting us a great deal of interest because it's latest and very efficient alternative to radio-based wireless technology. The possibilities are numerous and can be explored further. If this technology can be put into

practical use, every bulb can be used something like a Wi-Fi hotspot to transmit wireless data and we can proceed toward the cleaner, greener, safer and brighter future.

A growing number of people and their many devices access wireless internet, the airwaves are becoming increasingly clogged, making it more and more difficult to get a reliable, high speed signal. This may solve issues such as the short age of radio frequency bandwidth and also allow internet where traditional radio based wireless is not allowed such as aircraft or hospitals. One of the shortcomings however is that it only work in direct line of sight.

#### **ACKNOWLEDGMENT**

This paper is made possible through the help and support from everyone, including: parents, teachers, family, friends, and in essence, all sentient beings. We would like to thank Prof. Varun Mishra for her most support and encouragement. He kindly read our paper and offered invaluable detailed advices on grammar, organization, and the theme of the paper. We sincerely thank to our parents, family, and friends, who provide the advice and financial support. This paper would not be possible without all of them.

#### **REFERENCES**

- [1] International Journal of Applied Engineering Research, ISSN 0973-4562 Vol.7 No.11 © Research India Publications, 2012
- [2] An article on LI-FI appeared in The Economist (Jan 28th 2012): Visible-light Communication: Tripping the light fantastic - <http://www.economist.com/node/21543470>
- [3] Li-Fi Consortium - <http://www.lificonsortium.org>
- [4] Wireless data from every light bulb Harald Haas, TED Global, Edinburgh, July 2011
- [5] Li-Fi Technology - <http://oledcomm.com/lifi.html>
- [6] ISP Review - <http://www.ispreview.co.uk/index.php/2013/01/tiny-led-lights-set-to-deliver-wifi-style-internet-communications.html>, January 2013.
- [7] Li-Fi, Internet at speed of light - [gadgeteer.com/2011/08/29/Li-Fi-internet-at-the-speed-of-light/](http://gadgeteer.com/2011/08/29/Li-Fi-internet-at-the-speed-of-light/)