

Humanoid Robotic Arm

Arti Babar¹ Swaraj Chiwhane² Shubham Pawar³ Mohit Surase⁴ Poonam Gupta⁵

⁵Project Guide

^{1,2,3,4}Department of Computer Engineering

^{1,2,3,4,5}G. H. Raisoni College of Engineering & Management, Pune, Maharashtra, India

Abstract— A basic Robot plays quite important role in making our lives more efficient and productive. Here we propose to build a robotic arm controlled by human arm movement gestures whose input is acquired through the use of Leap motion sensors. The basic development of this arm is based on Arduino UNO platform in addition with leap motion controller for input processing, which will all be interfaced with each other using wireless module. The Arduino UNO kit is programmed to restrain the servo motors and Arduino's input is passed to the motion sensors. For proper control mechanism and flexibility of the arm, six different servo motors are used. Finally, this prototype of the arm may be supposed to overwhelm the problem such as place or pick difficult objects or non-hazardous objects that are at a long distance from the user and performing daily household activities with accuracy.

Keywords: Hand detection, Gesture Control, Leap Motion, Humanoid Robotic Arm

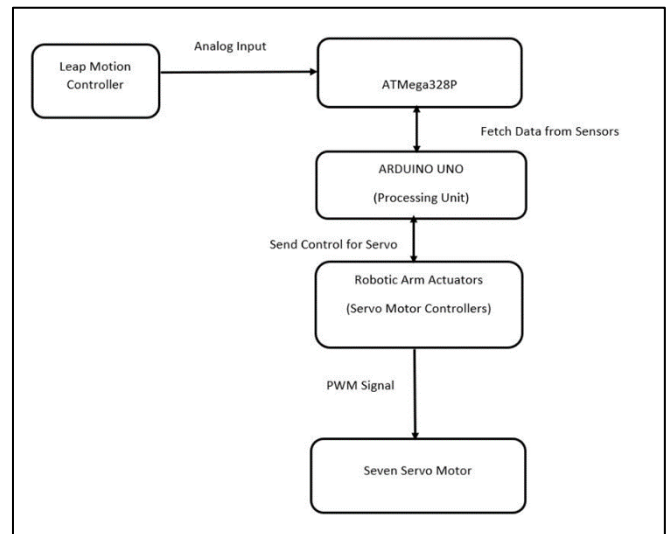

Fig. 1: Flowchart of the System

I. INTRODUCTION

In early years, we used keypad or joystick to control the robotic arm. It required a great deal of practices and figuring to control the mechanical arm to get it to the ideal position. The usage of the leap motion cause to explicitly acquire the hand gesture and gives set of points. Existing system consist of robotic arm that can be used only for pick and place, the arm is based on Arduino UNO microcontroller one servo and three DC motors are connected depending upon the system it will work. The existing system has quite shorter cycle times and cannot interact with human and also needs constant monitoring. To enhance the arm and resolve the difficulties in existing system we improved the whole system by transmitting the information in form of wired and added the prosthetic arm which consists of five fingers and can overcome the limitations of existing system. Also by adding 5 DC motors, each for one figure and one for the wrist, the efficiency of arm is increased.

The proposed arm is able to pick and place 4-5 kg of weight which will help humans reduce their work. An arm with five fingers can grip objects in one instance and in better way which is an advantage.

II. LEAP MOTION CONTROLLER

The Leap Motion Controller is a device that connects with a PC or Mac and allows the users to control the digital objects via motions. Leap Motion controller is a USB device that works on the basis of infrared technology. Its two Infrared cameras and three Infrared LEDs I detects the movement of hands done on the top of device. Like any hardware, the strength of this technology goes to be within the apps and there aren't any groundbreaking apps yet. The LED's inside the Leap Motion device generate pattern less Infrared Light and also the cameras produce around 200 frames per second of the reflected data. This data is passed to the connected computer via USB cable. The Leap Motion Software analyzes the data using "complex mathematics" in such a way which is still not revealed by the company. Somehow, it synthesizes the 3D position data by comparing the 2D frames created by 2 cameras.

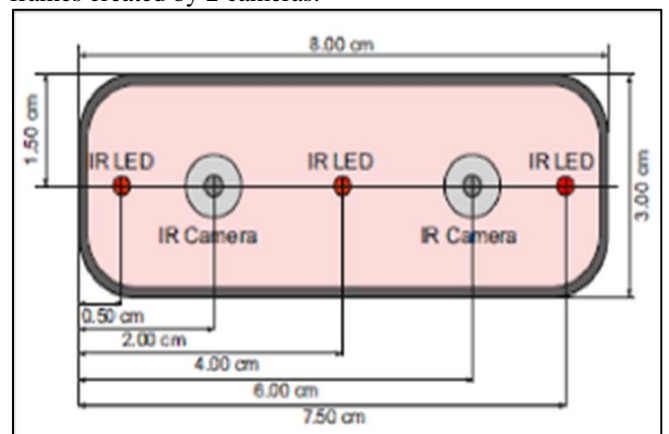

Fig. 2: Construction of Leap Motion Controller

This device constitutes a wide interaction area of eight cubic feet, which develops into an inverted pyramid –

the meeting point of the two cameras'. Earlier, the device controller's capture range was hardly up to 2 feet i.e. 60 cm above the device. With the help of Orion beta software, we are able to expand it to 2.6 feet i.e. 80cm. This range is prohibited by LED light proliferation via space, as it turns out to be a lot of hard to gather your hand's position in 3D besides a specific separation. Driven light force is naturally confined by the most extreme current that can be drawn over the USB connection.

The USB controller of the device reads the information received from the sensors into the local memory and performs the required resolution changes. This information is then cascaded by means of USB to the Leap Motion detecting software. The information appears as gray scale stereo appearance of the close infrared light range, isolated into the right and left cameras. Normally, the main objects you can see are those straightforwardly enlightened by the Leap Motion Controller's LEDs. Nonetheless, incandescent light will remove the darkness from the scene in infrared. You may likewise see that specific things, similar to cotton shirts, can seem white regardless of whether they are dull in the spectrum.

III. SYSTEM ARCHITECTURE

To overcome the limitations of the existing system we are going to make robotic arm which is controlled by "Leap motion controller". The robotic arm is mechanical arm with nearly similar functions to a human arm and it is programmable according to the requirement of the users. It can perform variety of functions and can perform the tasks where human can't go. While assembling the fingers, the parts are adjusted accurately before attachment. We are keeping all servo motors at specific degrees before appending the servo pulleys to servo motors. When attaching the servo pulleys, keeping all the fingers in the same position (according to the servo angles). Then wrapping around the servo pulley unless braid wires or strings gets extended.

After servo motors are fixed inside the forearm, to connect the servo's to the power supply and Arduino, we are using a breadboard. Negatives of the breadboard are connected to 'GND' port of Arduino. And all the GND's are connected with each other.

Connections to the Servo Motors:

- Servo Motor-1 connected to port i6 of the Arduino.
- Servo Motor-2 connected to port i7 of the Arduino.
- Servo Motor-3 connected to port i8 of the Arduino.
- Servo Motor-4 connected to port i9 of the Arduino.
- Servo Motor-5 connected to port i10 of the Arduino.

The leap motion communicates and send signal to Arduino with the help of computer and the microcontroller ATmega328p sends the angles to servo motors and rotates them accordingly. With the help of fish wires the moments of fingers are controlled and five motors are used for fingers and one servo motor for wrist rotation.

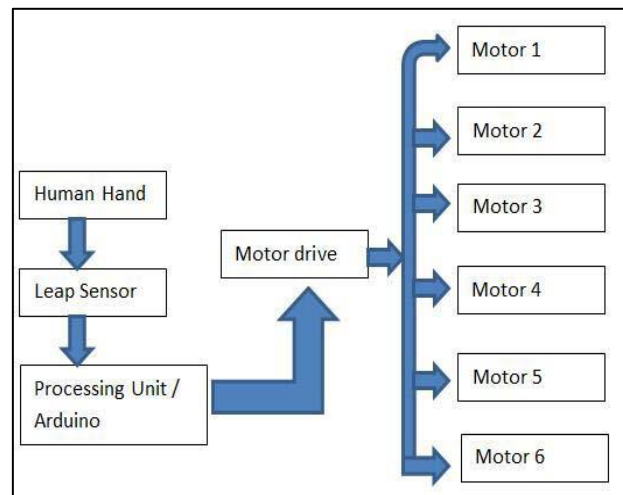

Fig. 3: Architecture of humanoid arm

IV. GRAPHICAL USER INTERFACE

Processing is often used for basic Graphical user interface (GUI interface) which is here used for controlling the robotic arm a public-domain programming language and development environment. At first it was brought into existence as software sketchbook and to teach computer programming fundamentals within a ocular context. Serial functions are directly available in the processing for pushing the serial data through Bluetooth. The Processing application sends servo data to the Arduino adaptable board in an easy format.

V. INTERFACE

Arduino has an existing processing library. This library is used for the processing and communicating. This library permits you to regulate an Arduino board from Processing without writing code for the Arduino. Alternatively, you upload a standard firmware code (program) to the board and communicate with it using the library. The firmware is termed Firmata, and is enclosed within the Arduino software. The robotic arm is moving in accordance with the Movement of the leap motion sensor. The leap motion detector is connected to the computer system. Interface is created using the processing software which accepts the data from the leap sensor. The Interface has sliders that controls the servo motors. The data is given to the Arduino through Bluetooth. Arduino receives the data which has been interfaced with processing. Hence, the data from leap sensor is send through Bluetooth to the arduino board. We have written aduino code for controlling the motors. Using the arm and finger movements we can control the robotic arm.

VI. APPLICATIONS

We have developed 'Humanoid Robotic Arm' which has a main purpose of performing human tasks. This arm is specifically designed for reducing the human efforts and also physically challenged people so that they can perform daily tasks with ease. The robotic arm is mechanical arm with nearly similar functions to a human arm and it is programmable according to the requirement of the users. It allows us to perform tasks like get some help in household

activities, holding objects, cutting different items and also work in areas which are not suitable for humans such as nuclear affected, deep sea, high pressure and hostile climates like space stations. All the tasks that need to perform can be done using natural human arm movements with the help of leap motion technology.

VII. CONCLUSION

The main aim of making this paper is to mimic the real time hand movements into a robotic arm with the help of leap motion controller. Ongoing research suggests that it is possible to make a robot to copy the human movement. The system can be used in the field of robotics to reduce the human efforts and also ensures the safety of human as it can be used to reach the hazardous places. Our paper explains that leap motion technology would one day change the ways to interact with machines in the easiest way possible. The results concluded that the system is able to detect real time hand movements efficiently and mimic accordingly. For future development it can be considered that leap motion technology will enable new ways to human machine interaction in the field of robotics.

REFERENCES

- [1] Chung-HsienKuo, Yu-Wei Lai, Kuo-Wei Chiu, Shih-TsengLee. in "Motion Planning and Control of Interactive Humanoid Robotic Arms" IEEE International Conference on Advanced Robotics and its Social Impacts Taipei, Taiwan, Aug. 23-25, 2008.
- [2] Navneetlal BW, Rahul MP, Namrata SN Eknath SS. Hand gesture controlled robotic arm. International Journal on recent and Innovation Trends in Computing and Communication. 2016; 4(4):435-7.
- [3] Robot-arm control system using LEAP motion controller Y. Pititeeraphab | P. Choitkunnan | N. Thongpance | K. Kullathum | Ch. Pintavirooj 2016 International Conference on Biomedical Engineering (BME-HUST) Year: 2016 | Conference Paper
- [4] Controlling a robot using leap motion Chang Chen | Liang Chen | Xuefeng Zhou | Wu Yan 2017 2nd International Conference on Robotics and Automation Engineering (ICRAE) Year: 2017 | Conference Paper
- [5] https://www.youtube.com/watch?v=iv9nM_qTgPw&feature=youtu.be
- [6] <https://www.youtube.com/watch?v=xVpLQHQMaw>
- [7] <https://www.youtube.com/watch?v=kOXqSPvK0ls&feature=youtu.be>
- [8] <https://www.instructables.com/id/Mind-Controlled-Robotic-Arm/>