

# Design and Analysis of Wheelchair Lifting Mechanism for Public Bus

Waibhaw Meshram<sup>1</sup> Parag Narkhade<sup>2</sup> Sejal Ambade<sup>3</sup> Shubham Meshram<sup>4</sup> Sushil Bhokre<sup>5</sup>

<sup>1</sup>Professor <sup>2,3,4,5</sup>B.E Student

<sup>1,2,3,4,5</sup>Department of Mechanical Engineering

<sup>1,2,3,4,5</sup>G.H Raison Academy of Engineering & Technology Nagpur, Maharashtra, India

**Abstract**— The project's aim is to create a mechanism that will facilitate the transportation of people with disabilities in bus. This will encourage the integration of disabled people in the community and will also consist a technical challenge for the design. In this project the lifting mechanism in which the platform is lift vertically with the help of scissor mechanism. The main objective of the use of scissor mechanism is to reach the desire height or level. Now a day many disable people, old people and wheelchair have face the problem for getting on or off from the bus. This lifting mechanism will be help full for those disable people. The required data for the design of lifting mechanism will be collected from the bus such as ground clearance and chassis distance etc. with the help of measuring device. This study deals with the design and development of lifting mechanism used to lift wheelchair. In this project we will be creating CAD model of the mechanism and performing FEA on mechanism it will assist us to know the stresses and displacement.

**Keywords:** CAD Model, FEA, Scissor Lift

## I. INTRODUCTION

Many person such as disabled people, older people, pregnant women, and wheelchair users have facing the problem for getting on or off from a bus. They can not get on a vehicle alone and someone else should help them to get on and off. In several cases there are special vehicles that use ramp for transportation of disabled people. Wheel chair lift mechanism can be solving many problem of disable person. In our project we are design lifting mechanism for wheel chair which is help the wheel chair user to get in a vehicle. In this mechanism we uses scissor lift mechanism to lift the platform from ground floor to vehicle floor. A scissor lift is use to lift the weight vertically that consists of a platform. The mechanism incorporated to get this function with the use of linked, folding supports in a criss-cross pattern, known as a mechanical device. The pressure is applied to the outside surface of the lowest set of supports in order to get the vertical motion, because of this pressure the criss-cross pattern elongates to propel the work platform vertically upwards, the platform can be assisted with an extending 'bridge', this bridge helps in closer access in the work area thus eliminating inherent limits of only vertical motion.



Fig. 1.1: Scissor Lift

The scissor elevator contains multiple stages of cross bars which may convert a linear displacement between two points on the series of cross bars into a vertical displacement increase by a mechanical advantage factor. This issue depends on the position of the points chosen to attach with actuator and the number of cross bar stages. The amount of force needed from the mechanism is additionally amplified, and result in very large forces required to start lifting even a moderate quantity of weight if the actuator is not in an optimal position. Actuator force isn't constant, since the load ratio decreases as a function of lift height.

The lifts may be classified according to energy used as hydraulic, pneumatic or mechanical. Each of those mechanisms has its advantage and disadvantage, which are studied and change per its application in various industries. Scissor lift design is preferred over alternative lifting devices obtainable in the market because of its result. The frame is extremely durable & strong enough with an increase in structural integrity.

A. Types of scissor lifts are as follows

1) Hydraulic Lifts

The hydraulic scissors lift is operate using the fluid pressure that raises the platform via power through the utilization of pressurized hydraulic oil. Slight speed variation is possible due to temperature fluctuations that may alter the viscosity of the hydraulic oil.

2) Pneumatic Lifts

The pneumatic lifts are operated by using air pressure and they are very economical because the power supply is carried out by compressing the atmospheric air. Most of the units don't need electricity and so is used at anyplace where the air is available.

3) Mechanical Lifts

The mechanical lifts are extended through a rack and pinion system or power screw, each of which might convert rotational motion. All the electric lifts are mechanical. The benefit of mechanical lift is that the teeth of its gear system prevent from slippage essentially.

B. Purpose of the Project

The project consists in the development of the product until the stage of an analytical prototype and its modelling, the next stages being continued by the time the material resources are available.

The first aspects of the project were identified in order to be able to start the process of design. Among them there are:

- 1) The product has to be able to lift all types of wheelchairs (standard wheelchairs) and the maximum possible weight for these cases, which is 400kg.
- 2) The product has to adapt to the constraints of the bus design:
  - space inside the bus
  - time of operation

- safety
- stability
- accessibility.

## II. DESIGN CALCULATION

Given data: -

Weight = 400Kg

Distance to lift = 860 mm

Assume Data: -

Length of Link= 800mm

Hydraulic Pressure = 3 N/mm<sup>2</sup>

Thickness of Link = 10 mm

Solution:

### A. Force Calculation:

Force required to lift 400 Kg weight

$$F = m \times g$$

$$F = 400 \times 9.81$$

$$F = 3924 \text{ N} = 4000 \text{ N}$$

### B. Design of Link for Bending:

$$\frac{M}{I} = \frac{\sigma}{Y}$$

$$\sigma = \frac{M}{I} \times Y = \frac{250}{1.5} = 166.67 \text{ mpa}$$

1) The load is acting on a half of a link

Total length = 800 mm

Half Length = 400 mm

$$\text{Total perpendicular force} = \frac{1}{2} \times b \times w$$

$$1000 = \frac{1}{2} \times 400 \times w$$

$$W = 5 \text{ N/mm}$$

2) Maximum bending moment (m)

$$m = \frac{wl^2}{9\sqrt{3}}$$

$$M = 51320.02 \text{ N-mm}^2$$

3) Moment of Inertia (I)

$$I = \frac{bh^3}{12}$$

$$I = 104166.66 \text{ mm}^4$$

Now,

$$\frac{M}{I} = \frac{\sigma}{Y}$$

$$\frac{51320.02}{104166.66} = \frac{\sigma}{25}$$

$$\sigma = 12.31 \text{ N/mm}^2$$

Allowable bending stress is less than yield stress therefore design is safe

### C. Design of Link for Buckling:

According to Euler's formula

$$\text{Critical Load} = P_{cr} = \frac{\pi^2 EI}{le^2}$$

$$P_{cr} = 84334.99 \text{ N}$$

We know that

$$A = b \times h = 50 \times 10 = 500 \text{ mm}^2$$

$$\text{Critical stress} = \frac{P_{cr}}{A}$$

$$= \frac{84334.99}{500}$$

$$\text{Critical stress} = 168.66 \text{ N/mm}^2$$

Calculated critical stress is less than the standard value of mild steel (250N/mm<sup>2</sup>) Therefore design is safe

### D. Design of Pin:

Allowable stress

$$\tau_{all} = \frac{0.5 \times \text{Yeild stress}}{\text{F.O.S}}$$

$$\tau_{all} = 31.25 \text{ N/mm}^2$$

Now,

$$\tau_{all} = \frac{P}{2A}$$

Where,

P = Force applied on pin

A = Cross section area of pin

$$\tau_{all} = \frac{2000}{2 \times \frac{\pi}{4} \times D^2}$$

$$D = 6.38 \text{ mm} = 10 \text{ mm}$$

### E. Hydraulic Cylinder Selection:

Mass = 400Kg

F = 4000N

P = F/A

Assume pressure is 3N/mm<sup>2</sup>

$$3 = \frac{4000}{\frac{\pi}{4} \times D^2}$$

$$D = 41.2 \text{ mm}$$

## III. CAD MODELING

### A. CAD Drawings:

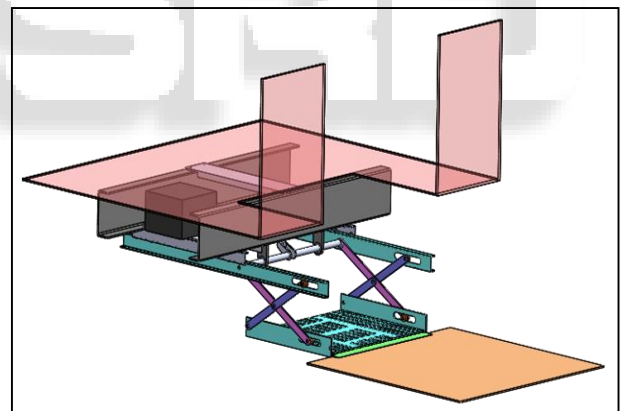

Fig. 3.1: Isometric view of lift at lower position

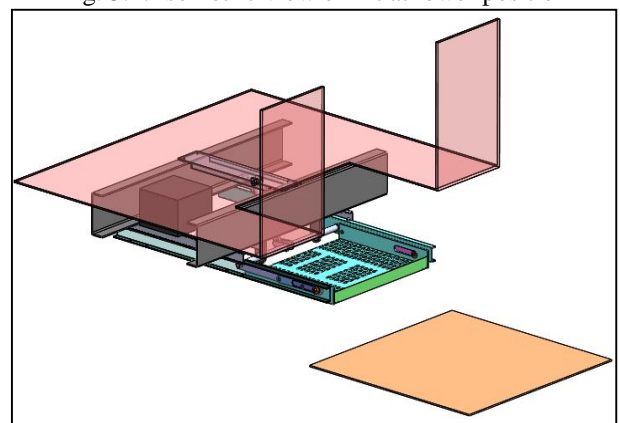

Fig. 3.2: Isometric view of lift at middle position

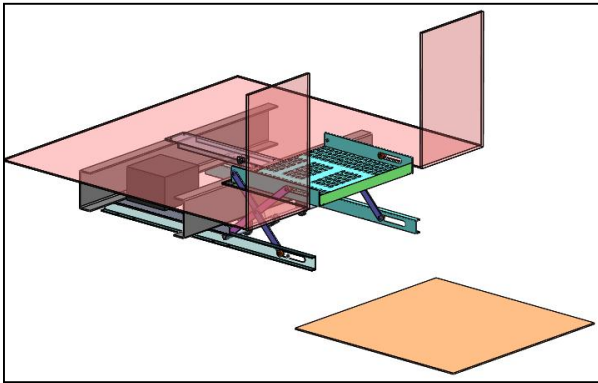

Fig. 3.3: Isometric view of lift at top position

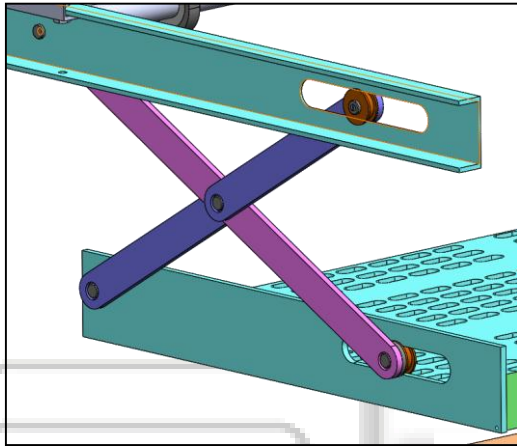

Fig. 3.4: Links

#### IV. FINITE ELEMENT ANALYSIS

##### A. Case I: Platform at Lower Position

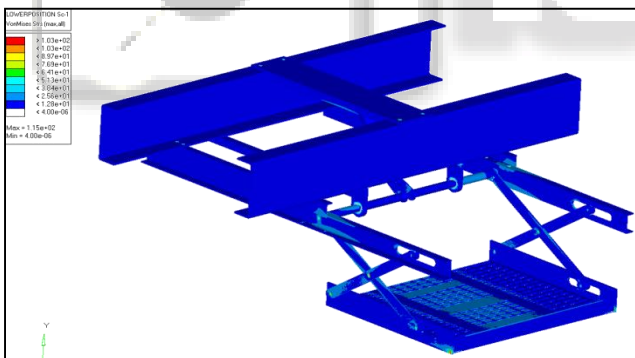

Fig. 4.1: Maximum Vonmises stress 115MPa in lift mechanism assembly

##### B. Case II: Platform at Mid level

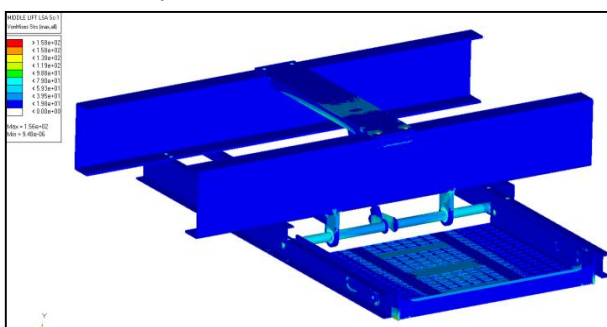

Fig. 4.2: Maximum Vonmises stress 156MPa in lift mechanism assembly

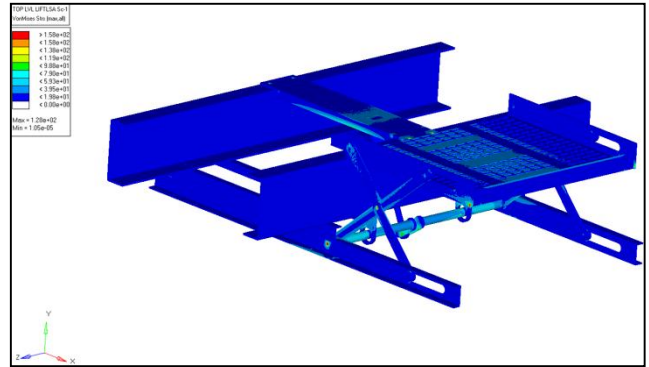

Fig. 4.3: Maximum Vonmises stress 128MPa in lift mechanism assembly

#### V. RESULT DISCUSSION

We have done the analysis of wheelchair lifting mechanism for 3 different cases and find out the stresses. In this all condition applied 4000N load on platform.

##### A. Case I: Platform at Lower Level

In this case the platform of the weight lifting mechanism start from the lower position. In this condition the maximum stress is 115 MPa on a link and assembly.

Parameter	Case I	Case II	Case III
Assembly	115 MPa	156 MPa	128 MPa
Shaft	88.6 MPa	116 MPa	97.4 MPa
Frame	69.7 MPa	69.7 MPa	58.7 MPa
Platform	76.8 MPa	109 MPa	91.5 MPa
Link	115 MPa	156 MPa	128 MPa

Table 5.1: Maximum Vonmises

##### B. Case II: Platform at Mid Level

The platform at mid position of the mechanism frame at this position the stress generates in assembly and link are 156 Mpa. In this case the stress is maximum other than two cases.

##### C. Case III: Platform at Upper Level

In this case the platform of lifting mechanism at bus floor level the maximum stress generate in assembly and link are 128 MPa and the stress in shaft is 97.4 MPa.

#### VI. CONCLUSION

The purpose of this project is to obtain the optimal design for lifting mechanism which is use for lifting the wheelchair on the bus. On the basis of objective, data accumulated and design calculations the CAD model of the lifting mechanism design using Solidworks. After CAD modelling the Finite Element Modelling and Finite Element Analysis was carried out by using HYPERMESH and Nastran to validate the Designed CAD model.

This analysis we calculate the stresses on assembly and other parts for 3 different cases and compare this stress with the material yield stress. The M.S material is used for the manufacturing because its cost is less and easily available. The yield stress of mild steel is 250MPa. The stress obtains from the analysis in case I platform at lowest position is 115MPa, stress in case II platform at mid position is 156MPa and stress in case III platform at top position is 128MPa. The maximum stress is 156MPa which obtain in case II this stress

compare with the material yield stress which is less than the material yield stress. The linear static analysis results shows that the stresses are well within the safe limit, hence the design is safe.

#### REFERENCES

- [1] ZHAO Cong, "The Design of Wheelchair Lifting Mechanism and Control System" Computer Aided Drafting, Design and Manufacturing Volume 24, Number 2, June 2014, Page 43
- [2] Rasoul Pourhassana, "Design of a Novel Mechanism for Transportation of Wheelchair and Disabled People into Public Buses" Australian Journal of Basic and Applied Sciences, 5(5): 866-874, 2011 ISSN 1991-8178
- [3] Long-Chang Hsieh, "The Innovative Design of Wheelchair with Lifting and Standing Functions" Proceedings of Engineering and Technology Innovation, vol. 4, 2016, pp. 10 - 12- 10
- [4] Y. Wilburt Moses Paul, "CONCEPTUAL DESIGN AND ANALYSIS OF EASY LIFT STAIRS FOR ELDERLY AND PHYSICALLY CHALLENGED PASSENGERS" International Journal of Scientific & Engineering Research, Volume 7, Issue 4, April-2016 83 ISSN 2229-5518
- [5] Gaffar G Momin, "Design, Manufacturing & Analysis of Hydraulic Scissor Lift" International Journal of Engineering Research and General Science Volume 3, Issue 2, Part 2, March-April, 2015 ISSN 2091-2730
- [6] M. Kiran Kumar, "Design & Analysis of Hydraulic Scissor Lift" International Research Journal of Engineering and Technology (IRJET) Volume: 03 Issue: 06 | June-2016