

Generation of Power by using Soil Cell

U. P. Dudhpachare¹ Prof. Rashmi Singh²

¹M. Tech Student ²Guide

^{1,2}VIT Nagpur, India

Abstract— In this paper a wireless environment monitoring system using renewable and cost-efficient soil energy. The D-size (55.8 cm³) soil energy cell with carbon and zinc electrodes can produce electricity depending on the water contents and microbial reactions in the soil. The soil cell is used for understanding the electrical characteristics of the cell. The wireless sensing system, including temperature and air moisture sensors, a custom low-power capacitive sensor readout silicon chip, a microcontroller, and a ZigBee transmitter, is to be demonstrated for long-term environmental monitoring solely by the fabricated D-size soil cell. The capacitive sensor readout chip is to be fabricated in a 0.18- μ m CMOS process. The total power consumption of the wireless temperature and air moisture monitoring system in the sleep mode and the active wireless data communication operations, should be within the acceptable values. The new technology can enable remote field environment monitoring with less labour-intensive work and battery replacement.

Key words: ZigBee, Soil Cell, Wireless, RC Circuit, CMOS, D-size

I. INTRODUCTION

Soil is the most spatially complex stratum on Earth, containing minerals and many organisms, such as bacteria, fungi, algae, protozoa, nematodes, and earthworms. The organic matter in subsurface environments and aquatic sediments represents a large potential source of energy. Some bacteria in the soil are known to generate electricity (exo-electrogens) without the provision of an exogenous media [6]. The soil energy can be an alternative energy source to remedy the environment and energy endeavours. Through biochemical reactions from the activities of the microorganisms, the energy in the soil can be released as electricity and heat. Recently, the chemical-to-electricity conversion processes from bacteria are utilized to establish microbial fuel cells [10]. The electrical properties of the soil are affected by the type of soil, density, operating frequency, water content, and soluble salts and minerals. The equivalent circuit provides insights for optimizing the MFC design and enhancing the output power.

The emerging technology of wireless sensor networks (WSNs) provides real time controls and communication with the physical world to reduce the risk of food shortages and casualties from disasters. To be widely deployed, wireless sensor nodes reliable energy source for their long-term operations. Wiring a power-source to sensors not only costs a vast amount of labor and resources but also leads to potential contamination produced by the batteries. To demonstrate the potential applications of the soil cells, we will design and fabricate a wireless temperature and air moisture sensing system on a printed circuit board (PCB). The capacitive humidity sensor readout IC will be employed to convert the humidity-caused capacitance deviations to frequency deviations. The readout IC will include a regulated RC oscillator and a DC-DC voltage boosting charge pump

circuitry. The data from the wireless sensors is sent to the microcontroller for data processing. The final readings will be sent to the ZigBee module for transmission to the smart phone as an output. Thus the overall system will include the DC-DC converter, low power microcontroller, air humidity sensor, custom capacitive humidity sensor readout IC, and a ZigBee transceiver with embedded temperature.

II. LITERATURE SURVEY

Design of a wireless environment monitoring system with the help of renewable soil energy. The microbial fuel cells developed for converting the chemical energy to electrical energy with the help of D-size cell. The wireless sensors are used to monitor the environmental conditions using wireless temperature and air moisture sensor system[1]. The system includes a DC-DC converter, low power microcontroller, air humidity sensor, custom capacitive humidity sensor readout IC, and a Bluetooth low-energy transceiver with embedded temperature sensor. The data from the temperature sensor is sent to the microcontroller for data processing. The microcontroller periodically wakes up the sensor and wireless transmitter only at a short-time interval. A synchronous loop is added to ensure that the microcontroller can capture the correct sensor data. Debris flows carrying saturated solid materials in water flowing down slopes often cause severe damage to the lives and properties in their path. Close monitoring and early warning are imperative to save lives and reduce damage. Current debris-flow-monitoring systems usually install sensor equipment along the riverbanks and mountain slopes to detect debris flows and track their data[2]. Unfortunately, most of this equipment indirectly collects data only from a distance. So far, there is no way to understand what is happening inside a debris flow and to collect its internal parameters, not to mention doing this in real time. To answer this challenge, this paper presents a novel multifunctional wireless sensor for monitoring debris flows. The core idea is to let these sensors drift with the debris flow, to collect flow information as they move along, and to wirelessly transmit the collected data to base stations in real time. The design of such a sensor needs to address many challenging issues, including cost, deployment efforts, long-term standby, and fast reaction. This paper addresses these issues and reports our evaluation results. Ultralow voltage nanoelectronics powered directly, and solely, from a tree. There are varying electrical potentials throughout the structures of vascular plants and their surrounding environments resulting from the transport of charged ions. Nanotechnology allows one to tap into these potentials to create a sustainable power supply which is useable by electronic circuits [4]. We characterized the performance of big leaf maple *Acer macrophyllum* trees as a power supply and found voltages on the order of hundreds of millivolts. Nanotechnology has enabled the creation of ultralow voltage and ultralow power circuits that can use living trees directly as a power source. We designed and fabricated two low-power

integrated circuits (ICs) for remote sensing networks and successfully powered them solely from *Acer macrophyllum*. The first circuit, built in a 130 nm CMOS process, is a boost converter generating a stable 1.1 V output. It consumes only 10 nanowatts when duty-cycled and it can operate on voltages as low as 20 mV. The second circuit, built in a 90 nm CMOS process, is a 0.045 Hz oscillator consuming only 2.5 nW during constant operation. These two circuits can provide useable voltage, timing signals, and “wake-up” functionality to remote sensor nodes in environmental monitoring [3]. The results of recent researches in electro-physiology have familiarised us with the view that any physiological process accompanied by chemical changes involves an associated electrical change. Haacke and Klein have shown that electrical currents in plants are essentially a manifestation of vital phenomena, and those differences in electric potential are connected both with respiration and carbon assimilation. Waller's investigations have also shown that the excitation of living vegetable protoplasm gives electrical response no less than that of animal protoplasm. He has demonstrated that leaves in a condition of active metabolism give an instant electrical response to the influence of sunlight, which was modified under conditions affecting protoplasmic activity. Apparently almost immediately upon the perception of the stimulus of light, electrical energy begins to be absorbed in the process of photosynthesis. Waller approaches very suggestively the existence of two opposing forces in the presence of analytic and synthetic processes, and recognises that the functions of assimilation and respiration might be mutually antagonistic as regards visible electric effects. His conception that "the product of dissociation gives current from the focus of dissociation, whereas a product of association, during its formation, gives rise to a current in the opposite direction," is of great interest.

III. RESEARCH ANALYSIS

- To design sustainable environment monitoring system
- To develop a system with low maintenance cost
- To use Soil Energy for environment monitoring using wireless sensor system
- To develop a Microbial fuel cell for converting chemical energy into electrical energy
- To implement temperature sensor and air-moisture humidity sensor using microcontroller
- To read the data of microcontroller using Silicon chip
- To transmit the readings by using wireless medium ZigBee transceiver
- To send the data to the smart phone

IV. METHODOLOGY

In this paper the method for communication is ZigBee interface is another part of the transmitter section. The pin 3 (data in) of ZIGBEE module is connected to the USART transmission (TX-25) pin of port C in PIC. This wireless transmission follows USART protocols and is according to IEEE 802.15.4. ZIGBEE is a transceiver, in the transmitter section it is used as the transmitter. The receiver address of this ZIGBEE module is set as the address of the ZIGBEE module in the main server, so that data is sent to this receiver

only. It is a low power, low cost wireless mesh networking standard and it uses the ISM band for its transmission. The details of this interface are given. The Controller requires oscillator for clock generation, for this a crystal oscillator 16 MHz is connected between pin 13 & 14. Parasitic capacitor of 33pf is used to increase the stability of the oscillator.

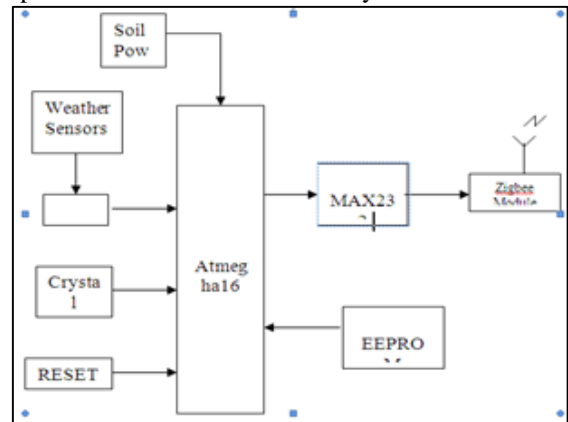

Fig. 1: Transmitter Section of the Wireless Monitoring System.

In the receiver section the ZIGBEE module can be used as receiver. This module receives the data sent by the transmitters. The supply to the ZIGBEE module (3.3V) is given by the supply circuitry in fig with LM317. To interface with the computer we have to convert the TTL logic into RS232 logic, for this purpose we use the IC MAX232. MAX232 is a dual driver/receiver that includes a capacitive voltage generator. The drivers (T1 & T2), also called transmitters, convert the TTL/CMOS logic input level into RS232 level. The transmitter (pin 10-T2 in) take input from ZIGBEE's data out pin (pin 2 of ZIGBEE) and send the output to RS232's receiver at pin 7 (T2 out) of MAX232. We use four capacitors, two for doubling the voltage and other two for inverting the voltage.

The capacitors are connected between pin 1 and pin 3, pin 4 and pin5, pin 2 and VCC, and pin 6 and GND. The transmitter output (T2 out) from MAX232 (RS232 logic) is connected to pin 2 (receive data) of RS232 port. Thus the data received are given to PC. The pin 5 of RS232 port is connected to ground.

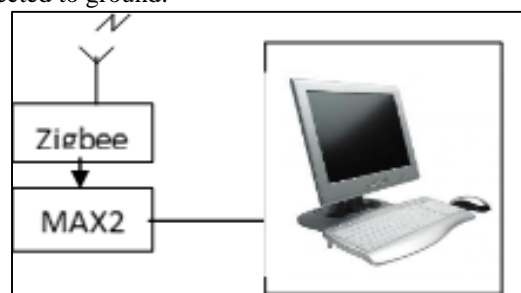

Fig. 2: Receiver Section of the Wireless Monitoring System.

In view of all these things, the design of wireless parameter progress helps in an industry to monitor the parameter in real time with the use of ZigBee, is an easy installation platform, cost-effective method for the low bit rate transmission, so with the help of the ready ZigBee platform by using the embedded language we interface the module with the PC by the help of Visual Basic we monitor the parameters in the system.

V. INTERFACING WITH SYSTEM

In this paper the ambient temperature will be displayed on. An 89s52 Microcontroller will be used for handling all the required computations and control. In following we have briefly discussed details of a Microcontroller and the project in general. A temperature sensor DS 1820 is used for sensing the ambient temperature. The system will get the temperature from the IC and it will display the temperature over the seven segment display and this temperature was compared with the value stored by the user and if the Transformer temperature goes beyond the Preset temperature then Coolant system will on and if temperature goes below to a fixed value then Coolant system will OFF.

A. PC Interfacing Circuit

In the receiver section the ZIGBEE module can be used as receiver. This module receives the data send by the transmitters. The supply to the ZIGBEE module (3.3V) is given by the supply circuitry in fig with LM317.

To interface with the computer we have to convert the TTL logic into RS232 logic, for this purpose we use the IC MAX232. MAX232 is a dual driver/receiver that includes a capacitive voltage generator. The drivers (T1 & T2), also called transmitters, convert the TTL/CMOS logic input level into RS232 level. The transmitter (pin 10-T2 in) take input from ZIGBEE's data out pin (pin 2 of ZIGBEE) and send the output to RS232's receiver at pin 7 (T2 out) of MAX232. We use four capacitors, two for doubling the voltage and other two for inverting the voltage. The capacitors are connected between pin 1 and pin 3, pin 4 and pin5, pin 2 and VCC, and pin 6 and GND. The transmitter output (T2 out) from MAX232 (RS232 logic) is connected to pin 2 (receive data) of RS232 port. Thus the data received are given to PC. The pin 5 of RS232 port is connected to ground.

VI. CONCLUSION

Compared to other renewable energies, such as solar and tidal energy, soil energy is easily accessible, insensitive to environment changes, and does not require expensive infrastructure. The system can be further utilized for remote field experiments and environment monitoring in energy-constrained areas to avoid frequent battery replacement. To improve the output power of a soil cell, cultured bacteria and prepared soil substrate can be used. The new technology can enable promising applications in environmental monitoring and green electronics.

REFERENCES

- [1] Yu-Chun Kuo, Jen-Chien Hsieh, Hsi-Yuan Tsai, Yu-Te Liao, Member, IEEE, and Huang-Chen Lee, Senior Member, IEEE, Fu-To Lin, Student Member, IEEE, "A Self-Powering Wireless Environment Monitoring System Using Soil Energy" ,IEEE SENSORS JOURNAL, VOL. 15, NO. 7, JULY 2015
- [2] H.-C. Lee, A. Banerjee, Y.-M. Fang, B.-J. Lee and C.-T. King, "Design of a multifunctional wireless sensor for in-situ monitoring of debris flows," IEEE Trans. Instrum. Meas., vol. 59, no. 11, pp. 2958–2967, Nov. 2010.
- [3] C. Himes, E. Carlson, R. J. Ricchiuti, B. P. Otis, and B. A. Parviz, "Ultralow voltage nanoelectronics powered

- directly, and solely, from a tree," IEEE Trans. Nanotechnol., vol. 9, no. 1, pp. 2–5, Jan. 2010
- [4] M. C. Potter, "Electrical effects accompanying the decomposition of organic compounds," Proc. Roy. Soc. London Ser. B, Contain. Papers Biol. Character, vol. 84, no. 571, pp. 260– 276, Sep. 1911.
- [5] M. Rahimnejad et al., "Thionine increases electricity generation from microbial fuel cell using *Saccharomyces cerevisiae* and exoelectrogenic mixed culture," J. Microbiol., vol. 50, no. 4, pp. 575–580, Aug. 2012
- [6] E. Parra and L. Liwei, "Microbial fuel cell based on electrodeexoelectrogenic bacteria interface," in Proc. IEEE 22nd Int. Conf. Micro Electro Mech. Syst., Jan. 2009, pp. 31–34.
- [7] D. R. Bond and D. R. Lovley, "Electricity production by *Geobacter sulfurreducens* attached to electrodes," Appl. Environ. Microbiol., vol. 69, no. 3, pp. 1548–1555, 2003.