

# A Novel Approach to Development of an Ultra-High-Speed Optical Signal Processing Technology in Optical Communication Systems

S.Kannadhasan<sup>1</sup> M.Shanmuganatham<sup>2</sup>

<sup>1</sup>Lecturer <sup>2</sup>Lecturer (S.G) & Vice Principal

<sup>1,2</sup>Department of Electrical & Electronics Engineering

<sup>1,2</sup>Tamilnadu Polytechnic College, Madurai, Tamilnadu, India

**Abstract**— Each time we take a count the number of subscribers for high-speed internet services increases, with the number of ADSL (Asynchronous Digital Subscriber Line). In an attempt to respond to such demand for large capacity optical communications technologies are currently being developed to increase the transmission speeds of optical signals and provide a highly dense multiplexing of wavelengths (DWDM: Dense Wavelength Division Multiplexing), as well as to expand the bandwidth for optical amplifiers. Out of all these technologies this paper concentrates on the ultra high-speed optical communication technology for increasing high-capacity communications and an overview of the 160Gbit/s optical transmitter receiver. This will be followed by a description of the orientation of recent research and development being conducted on a global scale with an introduction to the activities relating to the ultra high-speed optical signal processing technology.

**Key words:** Optical transmitter, Optical Receiver, Optical TDM, Optical 3R

## I. OVERVIEW OF OPTICAL TRANSMITTER – RECEIVER DEVELOPMENT

An optical Time division multiplexing (optical TDM) and demultiplexing technology was established to generate a 160 Gbps optical data signal from a series of mutually independent 40 Gbps data which were then demultiplexed back into 40Gbps optical data signals after transmission [1]. The optical TDM technology is intended to realize ultra high-speed optical communications that surpass the limits of operating speeds of electronic circuits. A conceptual diagram of the 160Gbit/s optical TDM method is provided in Figure 1. This method uses an Electro Absorption Modulator (EAM) for the generation of short pulses, the modulation of data and optical gating. The sender quadrifurcates the short optical pulses generated with a 40GHz electric clock signal before converting them into individually modulated data by using a 40Gbit/s electrical signal.

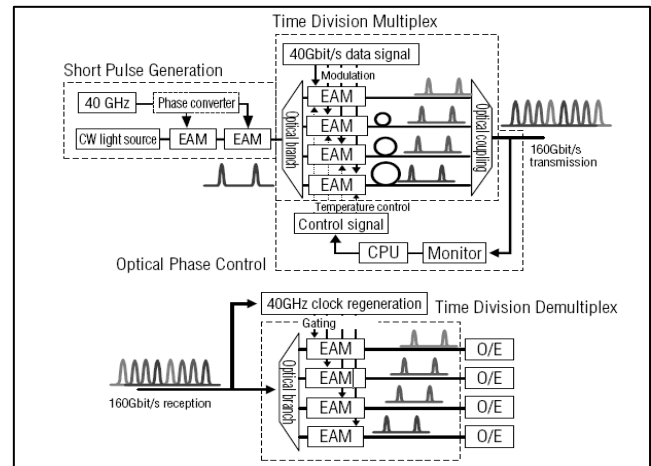

Fig. 1: Conceptual diagram of 160Gbit/s optical TDM method

This optical data signal is then used to generate a 160Gbit/s optical signal through a bit interleave with the condition of the light remaining the same in terms of temporal axis. The receiver regenerates a 40GHz electrical clock signal based on the 160Gbit/s optical data signal and the clock signal is used to perform optical gating for the condition of the light to convert the data signal into 40Gbit/s optical signals before the opt to-electrical conversion (O/E) takes place to obtain 40Gbit/s electrical data signals. Furthermore, this equipment is designed to allow the sender to monitor the signal being sent and set or sustain an arbitrary carrier wave phase difference for the four channels, as shown in the figure [2]. A 160Gbit/s optical transmitter-receiver, for which this method is applied, was developed to conduct validation experiments on the WDM transmissions of four wavelengths, as well as long distance transmissions that span as far as 640km.

## II. RESEARCH AND DEVELOPMENT OF ULTRA-HIGH SPEED OPTICAL COMMUNICATION TECHNOLOGIES

A lot of effort is being put into activities relating to ultra-high-speed optical communications using the optical TDM technology overseas as well. A glance over the activities conducted by major international academic organizations reveals that the number of announcements relating to 160Gbit/s transmissions has been increasing [3]. Research and development of ultra-high-speed optical communications in recent years has started developing a new vision as shown below, which stems from the perspective of accelerating speeds and extending capacity.

- Development of technologies for building optical networks that use existing infrastructures and are stable with a high performance and large capacity, at low prices.

- Waveform reshaping technologies, represented by the optical 3R (re-shaping, re-timing and re-amplifying) signal regenerations.

Studies into the waveform shaping technologies, such as the optical 3R signal regeneration technologies that respond to ultra high-speed signals at a rate of 80Gbit/s or higher, as well as new signaling methods, such as differential phase shift keying (DPSK), are also spreading [4]. The criteria for recent ultra high-speed optical communication technologies has started to shift toward compensation technologies for the optimization of existing networks, waveform shaping technologies for the purpose of long distance transmissions and others that can be categorized as ultra high-speed optical signal processing technologies intended for transmission speeds of 160Gbit/s.

### III. DEVELOPMENT OF ULTRA HIGH SPEED OPTICAL SIGNAL PROCESSING TECHNOLOGY

Since the development of the 160Gbit/s optical transmitter-receiver the following developments of ultra high-speed optical signal processing technologies have been performed, in order to apply the equipment to a practical system:

- 1) Channel slot identifying technology for the demultiplex of optical TDM signals.
- 2) Clock extraction technology that accommodates multiple bit rates.
- 3) Optical 3R signal regenerating technology for 80Gbps and 160Gbps optical signals.

### IV. CHANNEL SLOT IDENTIFICATION FOR OPTICAL TDM SIGNALS

A channel slot identifying technology is developed for optical TDM signals by using a control technology for the carrier wave phase difference between the channels of optical TDM signals, which is a characteristic of the 160Gbps optical transmitter-receiver. This technology is used to perform identifications based on the existing conditions of light (without opto-electrical conversions) in the time division demultiplexed channels of the receiver, as shown in Figure 1. This essential technology is for the interface when adopting the developed equipment to high-speed networks for ultra high-speed optical communications [5]. The optical phase changes the driving temperature of the EA modulator during bit interleaving for time division multiplexing and is controlled by adjusting the carrier wave phase difference. Figure 2 shows optical spectrums of various optical phases that have been generated using this technology, as well as optical signal waveforms. The optical phase is indicated by the difference in phase with the first channel (notated as '0'). It is possible to see the waveforms of optical spectrum emission lines, wavelengths and intervals change as conditions of the optical phase change [6]. For the condition of '0, 0,  $\pi$ ,  $\pi$ ' in Figure 2 (d), for instance, an optical spectrum line of 80GHz intervals (0.64nm intervals) is emitted. By expanding this fact further, we discovered that the component of 40GHz (spectrum line with 0.32nm intervals) was at its greatest when the condition was '0,  $\pi$ , 0, 0'.

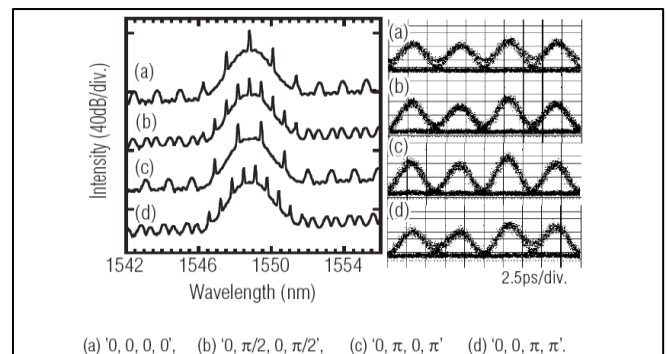

Fig. 2: Optical spectrums and optical signal waveforms for the respective phase conditions

Figure 3 shows the results of experiments indicating that channel slots can be identified. Results of the ordinary method (when the optical phase is '0, 0, 0, 0') are also shown for the purpose of comparison. The upper row of Figure 3 indicates the change in frequency when the voltage of the Voltage Controlled Oscillator (VCO) is cyclically changed. This is a situation wherein partial clock signals can be extracted by making such changes with amplitudes, which exceed the feeding range of the clock extractor as well as the retention range [7]. In other words a condition that remains constant with 39.81312GHz is a condition wherein the clock of a 40GHz signal can be extracted. By adjusting the quality of the four optical signals from a time division multiplex, on the other hand, it has become possible to identify the time division demultiplexed channels through the measurement of bit error rates (BER) at the time of reception.

The middle row of Figure 3 indicates the measurement results of BER and shows that the BER is measured when the clock signal is being extracted. Even though with ordinary methods the values of BER for separated channels differ depending on the situation, the value is constant with this method and the BER of all separated channels remains at  $6 \times 10^{-7}$ . Using this method, therefore, it is possible to verify that channel slots of optical TDM signals can be identified. Furthermore, the transmission range and dispersion resistance of these optical phase conditions were evaluated in simulations and verifications show that they do not undergo any extreme deterioration. There is, however, an issue regarding the occurrence of fluctuated eye height between channels of optical TDM signals when the driving temperature of the EA modulator changes. This arises due to the thermal dependency of the optical absorption characteristics of the EA modulator. Two methods are being considered to resolve this issue.

The first involves the monitoring of eye height changes arising from optical phase controls and equalization for fluctuation using a variable optical attenuator (VOA). Figure 4 indicates the circuitry for this method. Low frequency tone signals that vary in terms of frequency are superimposed at each channel and the optical TDM channel is identifiable from such tone signals. This is a method wherein the optical intensities of these four identified optical signals are input into the VOA calculation circuit where adjustments are made to equalize the eye height by applying VOA voltages [8]. Actual equipment has been prototyped and is currently used for the evaluation of collaborative operations with the optical phase controller.

The second method involves the positioning of liquid crystals in the optical path of the optical TDM module to control the optical phase by varying the applied alternating current voltage. Figure 5 shows the optical spectrums obtained when an optical phase control was performed by liquid crystals using short optical pulses of 40GHz with an actual prototyped quadruple multiplexing module. The waveform shown in (a) represents the optical spectrum when using ordinary 160GHz pulse strings (equivalent to Figure 4 (a) when reverted to data signals), while (b) shows the optical spectrum when the carrier is suppressed (equivalent to Figure 4(c)). Both of these spectrums have realized a side mode suppression ratio of approximately 20dB, indicating that an optical phase control can be realized favorably by using liquid crystals. These two methods will be compared for studies in the future in order to establish an optimum channel slot for identifying a technology that uses the optical phase control technology.

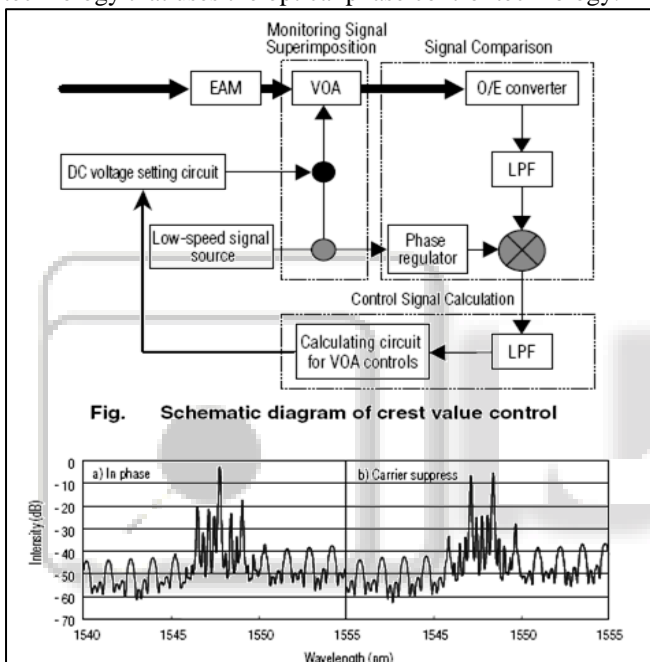

Fig. 3: Optical spectrum of 160GHz output light with 40GHz short optical pulse input

### V. CLOCK EXTRACTION TECHNOLOGY ACCOMODATES MULTIPLE BIT RATES

Clock signal generation plays an important role for the synchronization of the 160Gbit/s optical communication to networks of lower speeds (such as OC-N, where N=768, 192, 48 or 16) via Optical Add Drop Multiplex (ADM) or Cross Connect (XC). A clock extractor that supports multiple bit rates was created by further Clock signal generation plays an important role for the synchronization of the 160Gbit/s optical communication to networks of lower speeds (such as OC-N, where N=768, 192, 48 or 16) via Optical Add Drop Multiplex (ADM) or Cross Connect (XC). A clock extractor that supports multiple bit rates was created by further.

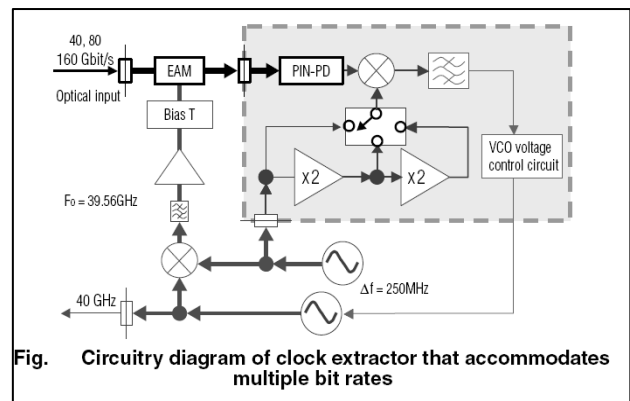

Fig. 4: Circuitry diagram of clock extractor that accommodates multiple bit rates

A circuitry diagram of the clock extractor, which accommodates multiple bit rates, is shown in Figure 6. When the electrical signal resulting from the mixing of the 40GHz clock signal with the component of difference in frequencies ( $\Delta f$ ) used for phase difference comparisons is input into the RF terminal of the EA modulator, by entering 40, 80 and 160Gbps optical signals in the optical input section of the EA modulator, the PIN-PD outputs are  $\Delta f$ ,  $2x\Delta f$  and  $4x\Delta f$  respectively.

When the phase difference comparison signal is switched to  $\Delta f$ ,  $2x\Delta f$  and  $4x\Delta f$ , the 40GHz electrical clock signal can be extracted from the optical signals of the three aforementioned bit rates. Prototype equipment was actually built and as an initial evaluation the 160Gbps optical signals, along with the 80Gbps and 40Gbps optical signals (pulse widths of 3ps) generated from the 160Gbps optical signals, were used to verify that clock signals can be extracted from the three types of bit rates respectively.

The performance of the prototyped clock extractor that accommodates multiple bit rates was evaluated by comparing it with the performance of the conventional clock extractor (dedicated to 160Gbps) [9]. The capture range and locking range are 0.7MHz and 8MHz respectively when using 160Gbps optical signals. This resulted in a narrower scope than the performance of the conventional clock extractor (capture range of 1.2MHz and locking range of 11.5MHz). This may occur due to the frequency components mutually affecting the components of the phase difference as noise. Furthermore, with regard to the phase jitter, no superimposition of jitter was found other than the variance arising from multiplications, with 1% or less (0.06ps or less) for the one cycle time slot of 160Gbps signals, which is equivalent to the conventional extractor performance. In the future we intend to look into the possibility of extending the feeding range and retention range, as well as proceed with the evaluation of 40Gbps and 80Gbps optical signal inputs with adjusted pulse widths.

### VI. OPTICAL 3R SIGNAL REGENERATING TECHNOLOGY

As the speed of the optical signal is raised higher, the transmission range becomes shorter by distance inversely proportional to the squared speed. We have thus far been able to validate an error-free transmission of optical signals traveling at 160Gbps over a distance of 640km. Instead of maintaining this service in the domestic market we instead applied 160Gbps optical signal transmissions to backbone networks, as it is essential to extend the transmission range

to cover long distances. Furthermore, the optical 3R signal regenerators can be small in number for the WDM systems with basic transmission rates accelerated to ultra high-speeds (same overall transmission capacity with a reduced number of wavelength channels), thereby reducing economical limitations [10]. We are, therefore, working on an optical 3R regenerating technology for 80Gbit/s and 160Gbit/s optical signal transmissions. Initially we were looking into an optical 3R signal regenerating technology that utilizes cross absorption modulation (XAM) effects of the EA modulator, however, the operating speeds of EA modulators would not be able to support the rate of 160Gbit/s, since the performance of the regenerated optical signal was already inadequate at a rate of 80Gbit/s. The current status of our efforts to deal with such issues is described below.

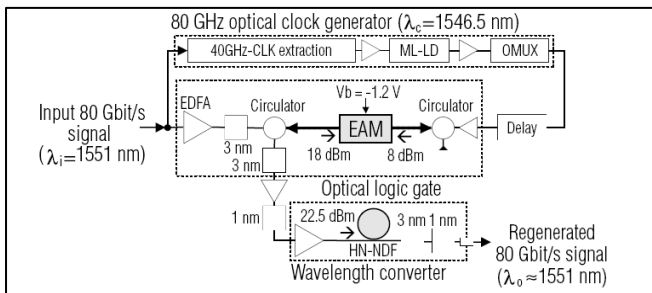

Fig. 5: Circuitry of 80Gbit/s optical 3R regenerating transponder

Figure 7 shows a circuitry diagram of an 80Gbit/s optical 3R signal regenerator. The circuitry is composed of blocks of the 80GHz optical clock signal generating section that provides a clock signal, which is synchronized to input 80Gbit/s optical signals, the optical logic gate section, which uses the XAM of the EA modulator, as well as the waveform reshaping and wavelength converting section that utilizes the normal dispersion fiber (HN-NDF: Highly Non-linear Normal Dispersion Fiber), self-phase modulation (SPM) and spectrum slicing.

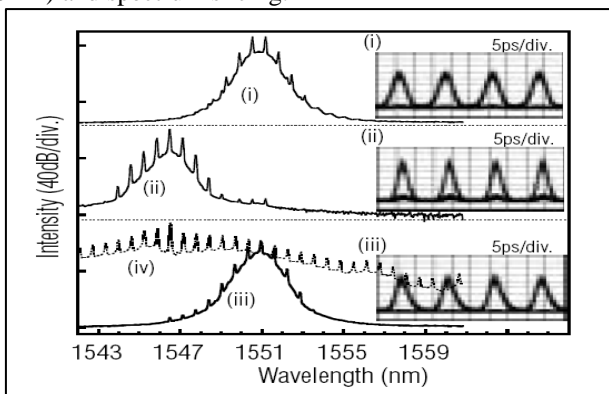

Fig. 6: 80Gbit/s signal regenerating process

Figure 8 shows the process of 80Gbps optical 3R signal regeneration from optical spectrums and optical signal waveforms. First of all, the 80Gbps input signal with a signal wavelength of 1551nm (i) collides with the 80GHz clock signal with a wavelength of 1546.5nm inside the EA modulator and converted into a regenerated signal with a wavelength of 1546.5nm (ii) by the XAM logic gate of the EA modulator. Next, this regenerated signal is spread like a spectrum (iii) by using the spectrum dispersion of SPM at HN-NDF and the optical spectrum is sliced off to a wavelength that is the same as the input signal. This then

results in the output of an optical 3R regenerated signal (iii). Even if the offset of the wavelength conversion from the optical spectrum, shown in Figure 8, is approximately 5nm it is clear that a favorable waveform shaping effect is obtained.

This waveform reshaping effect in particular is verified to be contributing to the elimination of noise at zero levels (spaces) in comparison with the waveform of the optical signal. A cyclical transmission experimentation system was actually built to conduct transmission experiments by regenerating and relaying 80Gbps optical 3R signals. The cyclical transmission experimentation system is comprised of a non-zero dispersion-shifted fiber (NZDSF), two spans of an 80km range, an optical amplifier and a dispersion compensation fiber (DCF). The reception sensitivity for each cycle (stipulated with BER = 10<sup>-9</sup>) for each case with or without optical 3R signal regeneration is shown on the left, BER is shown on the upper right and an eye diagram indicating the condition after transmission over 11,200km is shown on the lower right of Figure 9.

Results obtained showed that when the optical 3R signal regeneration and relay are not performed, there is a deterioration of reception sensitivity by approximately 10dB over the transmission range of 800km, whereas when the optical 3R signal regeneration and relay are performed the deterioration of the reception sensitivity decreases with the extension of the transmission range and yields an almost constant reception sensitivity (- 22dBm) at a transmission range of 1,000km or more [11]. It was verified that if an optical 3R signal regeneration and relay are not performed, a significant error floor will occur at a range of 800km, whereas if a transmission is performed with the optical 3R regeneration and relay the transmission will remain error-free beyond the transmission range of 5,600km. Furthermore, no significant deterioration in the waveform was seen in the eye diagram after transmission over an 11,200km range, which yielded a result with the highest level in the world for a transmission rate of 80Gbps.

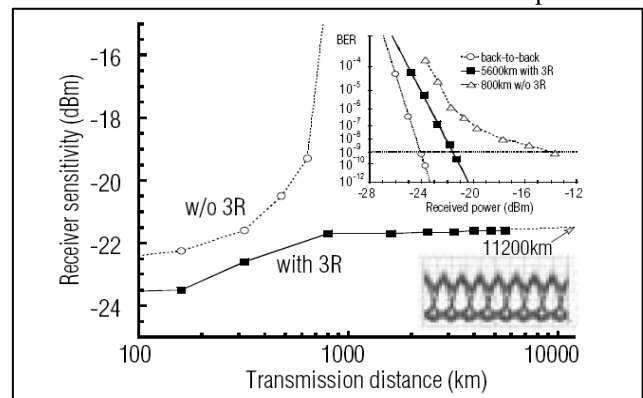

Fig. 7: All optical 3R transmission evaluation results

On the other hand for the 160Gbps optical 3R signal regeneration, the initial study on the optical signal regeneration technology uses a fiber base optical logic gate that adopts, instead of the XAM effect provided by the EA modulator, the non-linear effects provided by the nonlinear loop mirror (NOLM), which is known to have a superior high-speed response performance and is capable of performing the 160Gbps signal regeneration. Figure 10 shows the experimentation system for 160Gbps optical 3R signal regeneration.

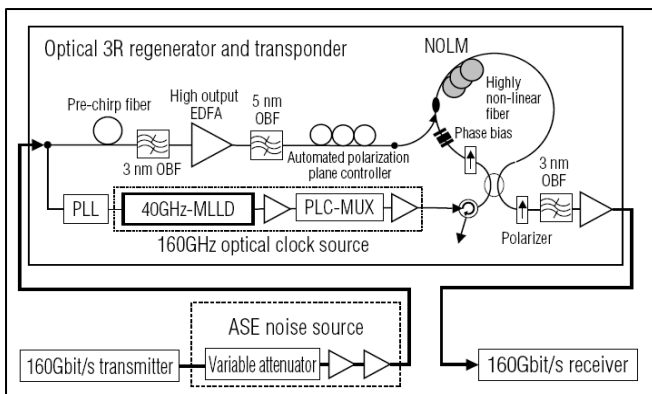

Fig. 8: 160Gbit/s signal regeneration experimentation system using non-linear loop mirrors (NOLM)

Highly non-linear fiber is connected in a loop with the NOLM via an optical coupler and the 160GHz optical clock signal is propagated in both directions, clockwise and counterclockwise [12]. The 160Gbps transmission signal is input to propagate in the clockwise direction via an optical coupler located on the loop. The phase of the 160GHz optical clock signal propagated in the same direction is changed by 180 degrees depending on the signal pattern.

The optical clock signal with an optical phase changed in this manner is output from the output port of the optical coupler as a regenerated signal. Figure 11 indicates the results of the evaluation on the change in the signal quality (Q factor) resulting from the application of the optical 3R signal regeneration to the signal with which the optical signal-to-noise ratio (SNR) deteriorated. We were able to verify the prospective of the NOLM functioning effectively as a logic gate since we were able to obtain improvements with the Q factor by up to a maximum of 2.5dB after the regeneration of the optical 3R signal. We believe that further improvement of the optical 3R signal regeneration performance is possible in the future through such means as reducing the NOLM insertion losses as well as optimizing the configuration.

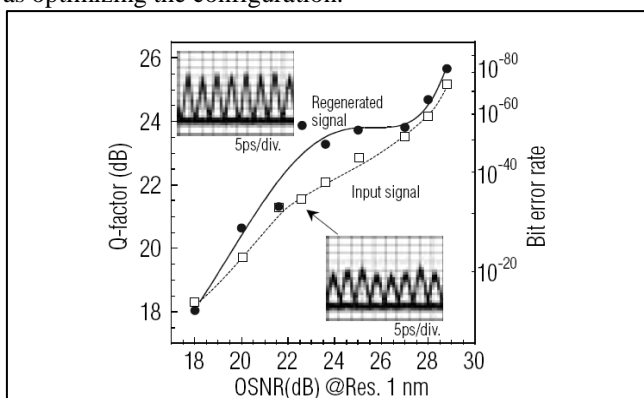

Fig. 9: Performance of 160Gbit/s signal regeneration by NOLM

## VII. CONCLUSION

The ultra-high-speed optical communication technologies suited for ultra-high-speed and large capacity communication networks on a global scale are often reported to have a transmission speed of 160Gbit/s by many organizations. In order to realize such applications in actual networks it is essential to have ultra-high-speed optical signal processing technologies that include compensating

technologies for wavelength dispersions and polarized dispersions on transmission lines, as well as conversion technologies for bit rates and wavelengths. This paper described the current status of development for the channel slot identification of optical TDM signals, the extraction of clock signals accommodating multiple bit rates and the optical 3R signal regeneration technology using the 160Gbit/s optical transmitter- receiver. We expect many organizations to develop ultra-high speed optical signal processing technologies for the purpose of practical implementation and believe that in the near future 160Gbit/s ultra-high-speed optical communications will be implemented in the field. We hope that these technologies will greatly contribute toward the advent of the ubiquitous network society and make our lives richer.

## REFERENCES

- [1] A. Kim, Y. Ju, Y. Soo Kim, S.M. Nahm, Hybrid fiber radio systems for pico-cell communications, *Microw. Opt. Technol. Lett.* 33 (June (5)) (2002) 328–330.
- [2] S. Sarkar, S. Dixit, B. Mukherjee, Hybrid wireless-optical broadband-access network (WOBAN): a review of relevant challenges, *J. Lightwave Technol.* 25 (11) (2007 Nov.) 3329–3340.
- [3] B. Patnaik, P.K. Sahu, Long-haul 64-channel 10-Gbps DWDM system design and simulation in presence of optical Kerr's effect, in: *ACM-Conference on Communication, Computing & Security (ICCCS)*, NIT, Rourkela, 2011, pp. 62–66.
- [4] A. Sheetal, A.K. Sharma, R.S. Kaler, Simulation of high capacity 40 Gb/s long haul DWDM system using different modulation formats and dispersion compensation schemes in the presence of Kerr's effect, *Optik* 121 (2010) 739–749.
- [5] T. Schafer, E.W. Laedke, M. Gunkel, C. Karle, A. Posth, K.H. Spatschek, S.K. Turitsyn, Optimization of dispersion-managed optical fiber lines, *IEEE J. Lightwave Technol.* 20 (June (6)) (2002).
- [6] M. Ortsiefer, R. Shau, G. Bohm, F. Kohler, M.C. Amann, Low-threshold index-guided 1.5  $\mu\text{m}$  long wavelength vertical-cavity surface-emitting laser diodes with high efficiency, *Appl. Phys. Lett.* 76 (16) (2000) 2179–2181.
- [7] D. Kedar, S. Arnon, Urban optical wireless communication networks: the main challenges and possible solutions, *IEEE Commun. Mag.* 42 (May (5)) (2004) 2–7.
- [8] M. Najjar, H. Rezig, Performance study of high bit rate indoor wireless optical networks, in: *International Conference on Transparent Optical Networks-Mediterranean Winter*, December, Marrakesh, Central Morocco, 1991, pp. 1–5.
- [9] C. Singh, Y.N. Singh, J. John, K.K. Tripathi, A review of indoor optical wireless systems, *IETE Tech. Rev.* 19 (January–April (01&02)) (2002) 3–17.
- [10] L. Jia, J.Q. Liu, D.P. Taylor, Optical communication using subcarrier PSK intensity modulation through atmospheric turbulence channels, *IEEE Trans. Commun.* August (55) (2007) 1598–1606.
- [11] S.M. Haas, J.H. Shapiro, Capacity of wireless optical communications', *IEEE J. Sel. Areas Commun.* 21 (2003 Oct) 1346–1357.

- [12] B. Patnaik, P.K. Sahu, Design and study of high bit-rate free-space optical communication system employing QPSK modulation, *Int. J. Signal and Imaging Systems Eng.*, Inder Science Publication, in press.
- [13] H. Tapse, D.K. Borah, Performance of regular low density parity check codes over hybrid optical/RF channels, in: *IEEE-Global Telecommunications Conference (GLOBECOM)*, 2008, pp. 1–6.
- [14] L.C. Andrews, R.L. Phillips, *Laser Beam Propagation through Random Media*, SPIE Optical Engineering Press, Bellingham, Washington, 1998
- [15] D. Dahan, G. Eisenstein, Numerical comparison between distributed and discrete amplification in a point-to-point 40-Gb/s 40-WDM-based transmission system with three different modulation formats, *J. Lightwave Technol.* 20 (March (3)) (2002) 379–388.
- [16] Kagawa *et al.*: “640km SMF Transmission Experiment of 160Gbit/s Signal Using Four 40Gbit/s OTDM Modules”, 2003 General Conference of the Communications Society of the Institute of Electronics, Information and Communication Engineers, B-10-116, September 2003.
- [17] H. Murai *et al.*: “Single Channel 160Gbit/s Carrier-Suppressed RZ Transmission over 640 km with EA Modulator based OTDM Module”, *ECOC2003*, 2003.

