

Controlling LED based on Received Signal Strength Indication (RSSI)

Rahul Raikwar

M.Tech Student

Department of Computer Engineering

College of Engineering, Pune, India

Abstract— Now-days, wireless technology has grown widely in every field. They have become part of our daily home scenarios to improve the quality of life by obtaining information about environment, energy consumption etc. The world today uses different technologies like Radio Frequency (RF), Infrared (IR), Bluetooth, Zigbee and WiFi. These technologies have different advantages like feasibility, easy accessibility, scalability etc. In today's scenario, we make use of modern household appliances like LED lights, microwave, televisions etc. Different techniques are introduced so as to reduce the effort required in controlling these appliances. An effort is being made to enable the user to control the LED light remotely. An Arduino Uno board with microcontroller ATmega 328 is used for controlling the LED. The LED is connected to the Wifi module ESP 8266. The signal strength of wifi is measured using RSSI (Received signal strength indication). This signal strength is received on the android application in the smartphone. The different signal strengths received are compared and the LED connected to the Wifi with highest value of signal strength is controlled at any instant of time.

Key words: LED, Wifi, Arduino, ATmega 328, ESP 8266, RSSI

I. INTRODUCTION

The arrival of twenty first century saw a high rise in the invention and usage of different lighting appliances like CFL lights, LED etc. Internet also became the indispensable part of human life. Wifi provided an on-the-go availability feature to devices like mobiles, laptops etc. thus converting them into smart devices. More focus is given to make the controlling these devices and appliances easier for the users and in the least possible time. LED (Light emitting diode) is a two lead semiconductor light source. It is a p-n junction diode that emits light when activated. LED has many advantages over traditional light sources, including lower energy consumption, longer lifetime, improved physical robustness, smaller size and less switching time. The paper "Real Time Based Temperature Control Using Arduino", controls cooling system automatically according to the room temperature. The system is designed with Arduino (microcontroller) and Arduino are increasingly being used to implement control systems. Since the system is intended to control the cooling system, it is therefore important to understand Arduino controlled system well. Nowadays with the advancement of technology particularly in the field of micro-controllers, all the activities in our day-to-day living have become part of information technology and we find controllers in each and every application. Thus, the trend is directing towards micro-controller based paper works. A micro-controller contains a CPU, clock circuitry, ROM, Ram and I/O circuitry on a single integrated circuit package. The purpose of this paper work is to present control theory that is relevant to the analysis and design of controlled

systems, with an emphasis on basic concepts and ideas. It is assumed that a digital micro-controller chip with reasonable software is available for computations and simulations so that many tedious details can be left to the micro-controller. The control system design is also carried out up to the stage of implementation in the form of micro-controller programs. In this paper work, the program is written in Arduino IDE and facilitates the control of LED lights by using Wifi.

A. Motivation

The motivation behind this work was to enable the users to control LED lights by using the signal strength of wifi so as to make possible the controlling the lights remotely and in a less time. An android application was developed to control the lights with the help of mobile phone. An arduino uno board was used to communicate between the wifi and the android application. The signal strength of wifi was obtained by using the Received signal strength indication (RSSI).

B. Aims and Objectives

To enable the user to control the LED lights remotely using the signal strength of wifi with the help of android application through the mobile phone.

- To receive the signal strength of wifi over the android application with the help of RSSI (Received signal strength indication).
- To enable the user to control any light depending on the highest value of signal strength at any instant of time.

II. LITERATURE SURVEY

While looking for the hardware and the wifi module that suited the purpose of project, the major concerns were cost, easy to design the system and availability of the entire module. An arduino uno board was chosen to implement the system. It is an open source hardware that consists of single board microcontrollers and microcontroller kits. It is used for building digital devices and interactive objects that can sense and control objects in the physical world. It consists of both the physical programmable circuit board (microcontroller) and a piece of software or IDE (Integrated Development Environment) that runs on the computer. It consists of 14 digital input/output pins (of which 6 can be used as PWM outputs), 6 analog inputs, USB connection, Power jack, reset button etc. The microcontroller ATmega 328 is used with arduino. It is an 8-bit RISC based microcontroller with 32 KB of flash memory with read-while-write capabilities and combination of EEPROM and SRAM. Arduino boards are relatively inexpensive as compared to other microcontroller platforms. It is cross platform i.e. it can run on windows, macintosh and linux operating systems.

It is a low cost wifi chip with full TCP/IP protocol stack and microcontroller unit. It is a self-contained SOC which can give access of wifi to the microcontroller. It

comes with different AT commands firmware which allows to get functionality like arduino wifi shield. It is an economic module and has a huge and growing community support.

III. METHODOLOGY

We have taken 3 arduino uno boards, 3 wifi modules and 3 LED lights. The LED is connected to the pin 3 of arduino uno board. The pins 10 and 11 of arduino are connected to the pins 3 and 4 respectively of the wifi module. These are used for receive (RX) and transmit (TX) between arduino and wifi module.

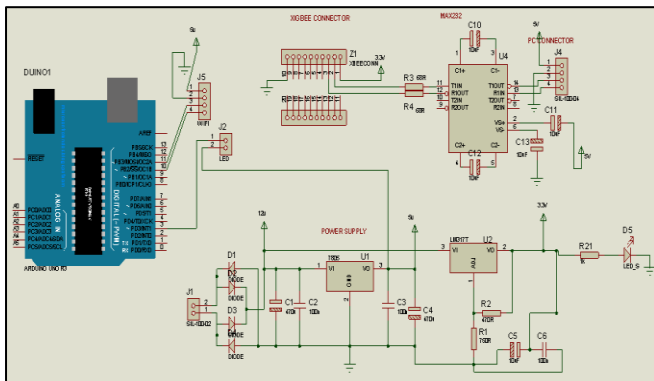

Fig. 01: System architecture

The power supply circuit consists of two capacitors of 1000 μ F and 100 nF each of which are connected in parallel to each other. They are used to maintain the proper voltage level of the current flowing through the circuit. Two ICs used in the power supply circuit are- LM 317 and 7805. The IC LM 317 acts as a positive voltage regulator. It is an adjustable linear voltage regulator. It is used to regulate the voltage of ESP 8266 wifi module. The IC 7805 is used to regulate the voltage of arduino uno board. It maintains the output voltage at a constant value.

The IP addresses of the three wifi modules are set to 192.168.43.79, 192.168.43.80 and 192.168.43.81 respectively. The network SSID is set to "project" and password is set to "12345678". When the power is turned ON, the wifi module sends its signal strength to the respective arduino uno board to which it is connected. It happens at a delay of every 10 secs. Now, the arduino uno board sends the received signal strength of the wifi to the android application at an interval of every 10 secs. The values of the signal strengths of all the three wifi modules are compared in the android application. When the user presses the LED On button, the LED with the highest value of signal strength will be turned ON. The android application sends the binary data using senddata(O) method to the corresponding arduino and the arduino turns the LED ON. When the android application sends the binary data using senddata(F) method to the corresponding arduino, that arduino turns the LED OFF. At any instant of time, the particular LED turned ON or OFF depends on the values of signal strength of the corresponding wifi module to which the LED is connected.

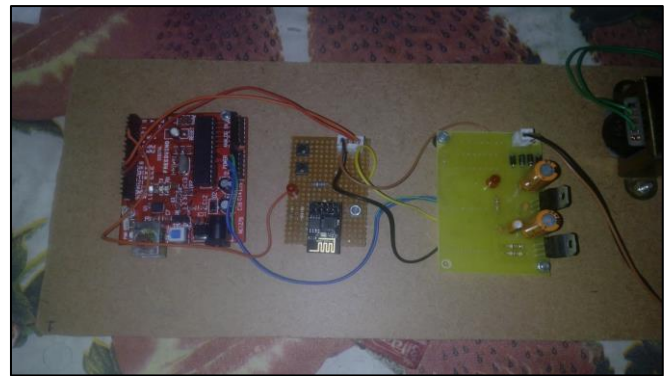

Fig. 02: System Design

IV. EXPERIMENTAL RESULTS

The android application controls the LEDs based on the values of signal strengths received from different wifi modules through arduino uno boards. The signal strength values are negative (0-100 dbm). But we have ignored the negative sign for ease of comparison.

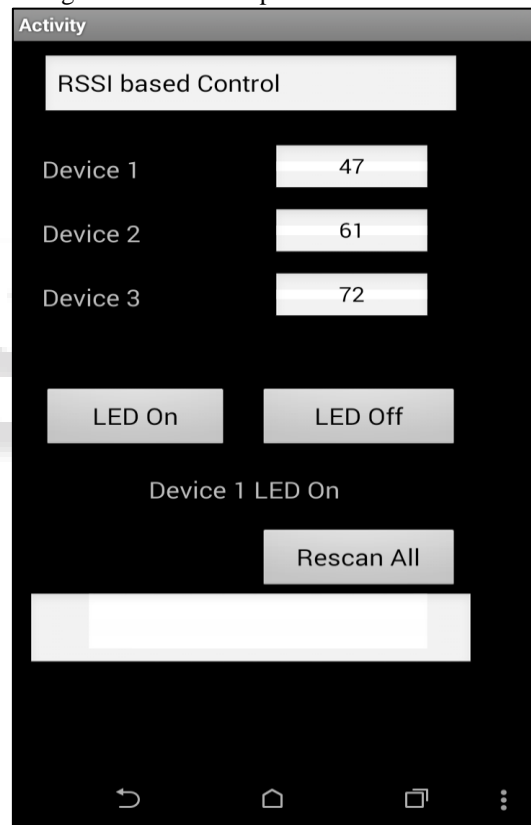

Fig. 02: LED 1 turned ON

In the above fig., the value of signal strength of wifi corresponding to LED 1 is highest. So, the LED 1 will become ON on clicking on the button.

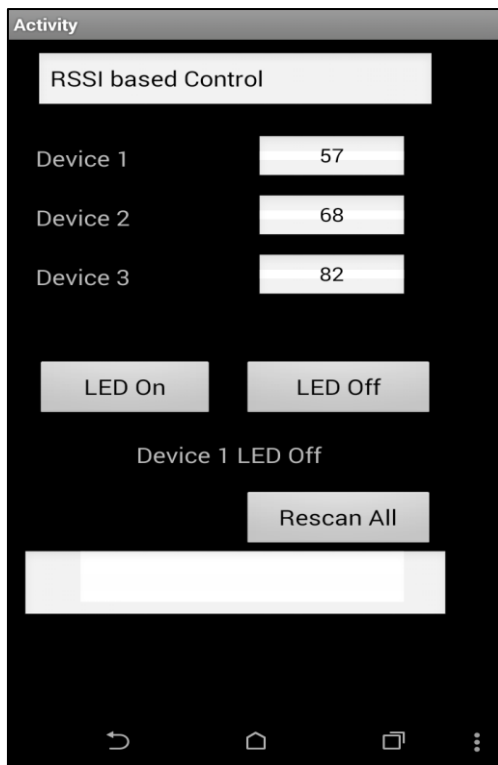

Fig. 03: LED 1 turned OFF

In the above, fig., as the value of signal strength of wifi corresponding to LED 1 is highest and if LED 1 is already turned ON, so the LED 1 will be turned OFF on clicking the button for LED Off.

V. CONCLUSION

The signal strength of wifi has been successfully used to turn the LED ON/OFF using RSSI with the help of android application. The arduino uno board is used to communicate between the LED and the android application. The user can control different LEDs from the android application through the mobile phone and the LED controlled at any instant of time depends on the location of the user as the signal strength of wifi varies with location.

VI. FUTURE SCOPE

The system of using arduino and wifi with RSSI can be used to lock and unlock the doors of a car with the help of android application.

The system of arduino with wifi using RSSI can have many applications in health care systems, disaster management systems, opening the door of a shop when the owner of a shop comes near the shop, airports, malls etc.

REFERENCES

- [1] Amir Atabekov, Jing He, Patrick Ooto Bobbie, "Internet of Things-Based Framework To Facilitate Indoor Localization Education", IEEE 40th Annual Computer Software and Applications Conference (COMPSAC), volume 2, 2016
- [2] Chaohui Lv, Yu Hao, Mengyuan Xie, " Intelligent Stage LED light control system based on Android Smartphone", 9th International Congress on Image and Signal Processing , Bio medical Engineering and Informatics, 2016

- [3] Diksha Sangla, Harmanjit Singh, Jitesh K Chawla, Smriti Ranjan, Shaina Parvanda, "Wi-Fi Signal Strength Indicator", International Journal of Computer Applications (0975-8887)
- [4] Navjot Kaur Walia, Parul Kalra, Deepti Mehrotra, "An IoT by Information Retrieval Approach: Smart Lights controlled using WiFi", 6th International Conference-Cloud System and Big Data Engineering, 2016
- [5] Arduino; Unsigned Long Data Type Reference Sheet, <https://www.arduino.cc/en/Reference/UnsignedLong>.