

# Solar Operated Automatic Seed Sowing Machine

John Chembukkavu<sup>1</sup> Aslam Basheer<sup>2</sup> Basil N Basheer<sup>3</sup> Sivasekhar BR<sup>4</sup>

<sup>1</sup>Assistant Professor <sup>2,3,4</sup>B. Tech. Student

<sup>1,2,3,4</sup>Department of Electrical & Electronics Engineering

<sup>1,2,3,4</sup>IESCE Chittilappilly PO Thrissur Kerala, India

**Abstract**— the real power required for machine equipment depends on the resistance to the movement of it. Even now, in our country 98% of the contemporary machines use the power by burning of fossil fuels to run IC engines or external combustion engines. This evident has led to widespread air, water and noise pollution and most importantly has led to a realistic energy crisis in the near future. Now the approach of this project is to develop the machine to minimize the working cost and also to reduce the time for digging and seed sowing operation by utilizing solar energy to run the robotic machine. In this machine solar panel is used to capture solar energy and then it is converted into electrical energy which in turn is used to charge 12V battery, which then gives the necessary power to a shunt wound DC motor. This power is then transmitted to the DC motor to drive the wheels. And to further reduction of labor dependency, IR sensors are used to maneuver robot in the field. Here 4 post sensors are used to define the territory and robot senses the track length and pitch for movement from line to line. Seed sowing and digging robot will move on different ground contours and performs digging, sow the seed and water the ground after closing.

**Key words:** Seed Sowing Machine, Solar Operated Automatic Seed Sowing Machine

## I. INTRODUCTION

Today the environmental impact of agricultural production is very much in focus and the demands to the industry is increasing. In the present scenario most of the countries do not have sufficient skilled man power in agricultural sector and that affects the growth of developing countries. Therefore farmers have to use upgraded technology for cultivation activity (digging, seed sowing, fertilizing, spraying etc.). So it's a time to automate the sector to overcome this problem. In India there are 70% people dependent on agriculture. So we need to study on improving agricultural equipment. Innovative idea of our project is to automate the process of digging and seed sowing crops such as sunflower, baby corn, groundnut and vegetables like beans, lady's finger, pumpkin and pulses like black gram, green gram etc. and to reduce the human effort. Since we have lack of man power in our country, it is very difficult to do digging and sowing operation on time, Automation saves a lot of manual work and speed up the cultivation activity. The energy required for this robotic machine is less as compared with other machines like tractors or any agriculture instrument, also this energy is generated from the solar energy which is found abundantly in nature. Pollution is also a big problem which is eliminated by using solar plate. The Project Proposal and Feasibility Study explored the feasibility of our chosen project, provided a structured plan for the design, and was a milestone for the project at the end of seventh semester. This Final Design Report discusses the design details of the project by displaying

various decisions the team made throughout the des process Lastly, it discusses future design work the team would like to do in the next prototype stage.

## II. LITERATURE SURVEY

In recent years, there has been an acute shortage of agricultural labourers during sowing season due to increased employment opportunities in urban areas for rural youth. Due to non availability of labour and work animals during sowing seasons, in many places the seed is sown even when the soil is at a low moisture content which affects the germination, plan I. Stand and yield. Therefore in order to mechanize crop sowing operation under rain fed conditions, a suitable seed drill is vital as it places the seed in the zone of adequate moisture and at desired depth. The bullock drawn seed drill gives proper seed rate, uniform distribution and correct placement of seed resulting in higher yield and reduces human physical strain.

## III. BLOCK DIAGRAM

The block diagram gives a brief idea about various important parts of the solar operated automatic seed sowing machine. Here the important parts are solar panel ,battery, microcontroller, DC motor. Microcontroller is brain of the system which will control the entire system in response to the instructions. Here solar panel is using for charging the battery. Battery is the power supply for the system. Four motors are used for digging and sowing mechanism and movement of the machine.

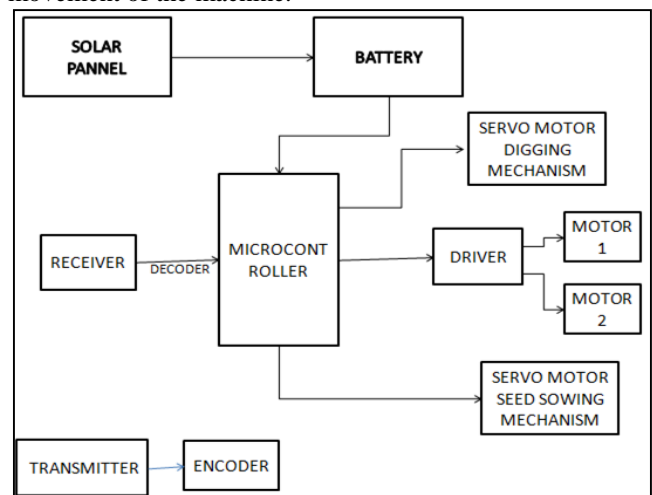

Fig. 1: Block diagram

#### IV. MICRO CONTROLLER: ATMEGA 328

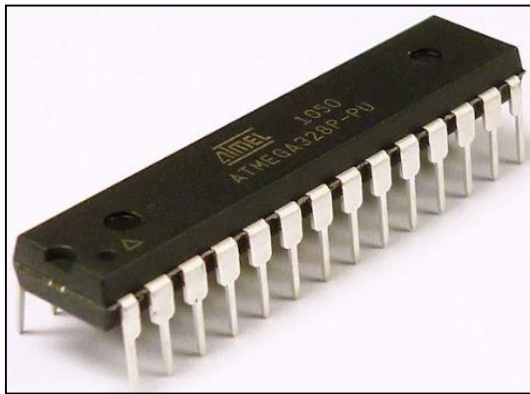

Fig. 2: ATmega IC

The high-performance Atmel 8-bit AVR RISC-based microcontroller combines 32 KB ISP flash memory with read-while-write capabilities, 1 KB EEPROM, 2 KB SRAM, 23 general purpose I/O lines, 32 general purpose working registers, three flexible timer/counters with compare modes, internal and external interrupts, serial programmable USART, a byte-oriented 2-wire serial interface, SPI serial port, 6-channel 10-bit A/D converter (8-channels in TQFP and QFN/MLF packages), programmable watchdog timer with internal oscillator, and five software selectable power saving modes. The device operates between 1.8-5.5 volts. By executing powerful instructions in a single clock cycle, the device achieves throughputs approaching 1 MIPS per MHz, balancing power consumption and processing speed.

Today the ATmega328 is commonly used in many projects and autonomous systems where a simple, low-powered, low-cost micro-controller is needed. Perhaps the most common implementation of this chip is on the ever popular Arduino development platform, namely the Arduino Uno and Arduino Nano models.

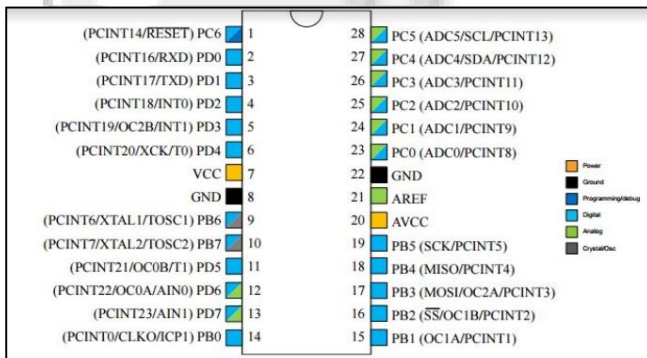

Fig. 3: Pin Diagram of ATmega 328

#### V. RF BIT TRANSMITTER RECEIVER

The RF module, as the name suggests, operates at Radio Frequency. The corresponding frequency range varies between 30 kHz & 300 GHz. In this RF system, the digital data is represented as variations in the amplitude of carrier wave. This kind of modulation is known as Amplitude Shift Keying (ASK). Transmission through RF is better than IR (infrared) because of many reasons. Firstly, signals through RF can travel through larger distances making it suitable for long range applications. Also, while IR mostly operates in line-of-sight mode, RF signals can travel even when there is an obstruction between transmitter & receiver. Next, RF

transmission is more strong and reliable than IR transmission. RF communication uses a specific frequency unlike IR signals which are affected by other IR emitting sources.

This RF module comprises of an RF Transmitter and an RF Receiver. The transmitter/receiver (Tx/Rx) pair operates at a frequency of 434 MHz. An RF transmitter receives serial data and transmits it wirelessly through RF through its antenna connected at pin4. The transmission occurs at the rate of 1Kbps - 10Kbps. The transmitted data is received by an RF receiver operating at the same frequency as that of the transmitter. The RF module is often used along with a pair of encoder/decoder. The encoder is used for encoding parallel data for transmission feed while reception is decoded by a decoder. HT12E-HT12D, HT640-HT648, etc. are some commonly used encoder/decoder pair IC.

#### VI. MOTOR DRIVER

L293D is a dual H-bridge motor driver integrated circuit (IC). Motor drivers act as current amplifiers since they take a low-current control signal and provide a higher-current signal. This higher current signal is used to drive the motors. L293D contains two inbuilt H-bridge driver circuits. In its common mode of operation, two DC motors can be driven simultaneously, both in forward and reverse direction. The motor operations of two motors can be controlled by input logic at pins 2 & 7 and 10 & 15. Input logic 00 or 11 will stop the corresponding motor. Logic 01 and 10 will rotate it in clockwise and anticlockwise directions, respectively. Enable pins 1 and 9 (corresponding to the two motors) must be high for motors to start operating. When an enable input is high, the associated driver gets enabled. As a result, the outputs become active and work in phase with their inputs. Similarly, when the enable input is low, that driver is disabled, and their outputs are off and in the high-impedance state.

##### A. Servo Motors

Servo motors have been around for a long time and are utilized in many applications. They are small in size but pack a big punch and are very energy-efficient. These features allow them to be used to operate remote-controlled or radio-controlled toy cars, robots and airplanes. Servo motors are also used in industrial applications, robotics, in-line manufacturing, pharmaceuticals and food services. The servo circuitry is built right inside the motor unit and has a positionable shaft, which usually is fitted with a gear (as shown below).



Fig. 4: Hitec HS-322HD Standard Heavy Duty Servo

To fully understand how the servo works, you need to take a look under the hood. Inside there is a pretty simple set-up: a small motor, potentiometer, and a control circuit. The motor is attached by gears to the control wheel. As the motor rotates, the potentiometer's resistance changes, so the

control circuit can precisely regulate how much movement there is and in which direction. When the shaft of the motor is at the desired position, power supplied to the motor is stopped. If not, the motor is turned in the appropriate direction. The desired position is sent via electrical pulses through the signal wire. The motor's speed is proportional to the difference between its actual position and desired position. So if the motor is near the desired position, it will turn slowly, otherwise it will turn fast. This is called proportional control. This means the motor will only run as hard as necessary to accomplish the task at hand.

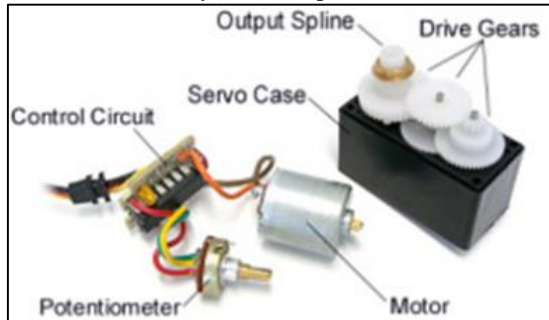

Fig. 5: The guts of a servo motor (L) and an assembled servo (R)

Servos are controlled by sending an electrical pulse of variable width, or pulse width modulation (PWM), through the control wire. There is a minimum pulse, a maximum pulse, and a repetition rate. A servo motor can usually only turn 90 degrees in either direction for a total of 180 degree movement. The motor's neutral position is defined as the position where the servo has the same amount of potential rotation in the both the clockwise or counter-clockwise direction. The PWM sent to the motor determines position of the shaft, and based on the duration of the pulse sent via the control wire; the rotor will turn to the desired position. The servo motor expects to see a pulse every 20 milliseconds (ms) and the length of the pulse will determine how far the motor turns. For example, a 1.5ms pulse will make the motor turn to the 90-degree position. Shorter than 1.5ms moves it to 0 degrees, and any longer than 1.5ms will turn the servo to 180 degrees.

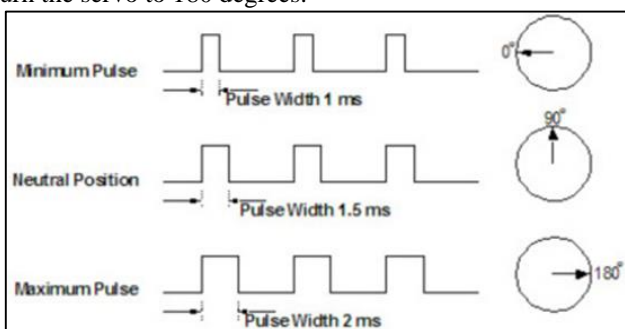

Fig. 6: Variable Pulse width control servo position

When these servos are commanded to move, they will move to the position and hold that position. If an external force pushes against the servo while the servo is holding a position, the servo will resist from moving out of that position. The maximum amount of force the servo can exert is called the torque rating of the servo. Servos will not hold their position forever though; the position pulse must be repeated to instruct the servo to stay in position.

### B. Servo Motor Applications

Servos are used in radio-controlled airplanes to position control surfaces like elevators, rudders, walking a robot, or operating grippers. Servo motors are small, have built-in control circuitry and have good power for their size. In food services and pharmaceuticals, the tools are designed to be used in harsher environments, where the potential for corrosion is high due to being washed at high pressures and temperatures repeatedly to maintain strict hygiene standards.

### VII. SOLAR PANEL



Fig. 7: Solar panel

A 15 W heavy duty aluminum framed solar panel is using for charging the 12 V battery. Solar panel is of size of 12 inch x 18 inch. Guarantee of power of solar panel is 90% within 10 years 80 within 25 years

### VIII. WORKING MACHINE

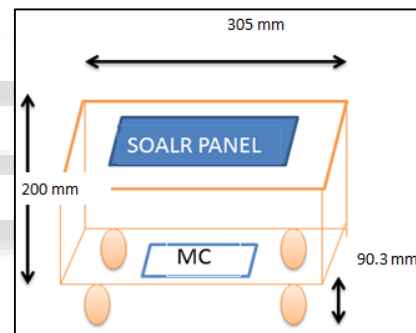

Fig. 8: Structure of Machine

#### A. Specification of seed drills

Sowing can be divided into two main phases. The uniform feed of seeds from the grain hopper to openers and the preparation of furrows, the placement, of seeds in them and covering of the furrows with soil to the same depth. Distribution of seeds on the area sown must be uniform. The metering mechanisms of die seed drills must drop the seeds uniformly. The average non-uniformity between separate mechanisms must not exceed 3 per cent for cereals and 4 per cent for leguminous crops. The amount of seeds in each row must be the same and must correspond to the adopted seed rate. During sowing, seeds must not be damaged in the metering mechanisms, openers and other parts of the seed drill. Furrow openers must create a slightly compressed furrow bottom and the furrow depth must be constant. Seeds are laid on the compressed bottom and covered with wet soil.

#### B. Factors which influence the improvement of seed drill design

The design of agricultural mat bines involves the understanding of the variable field conditions and other

factors which influence machinery performance, including environmental and human related factors. Machines should be operationally reliable and economically acceptable to the farmer. In the case of agricultural machinery design, the relevant scientific principles concerning soils, plants and plant, parts and other biological materials are also considered. Designers of farm machines must integrate analytical design and results of experimental investigations which are simple to fabricate, affordable, light in weight, easy to maintain, and require readily available and low-cost materials.

#### IX. CONCLUSION

We have studied well about the project work of solar operated automatic seed sowing machine. We wish to complete this project in section wise. As the first step by taking some approximate measures we designed a machine structure and components to be used and their ratings. After that for choosing the main component dc motor is depended up on the net weight of the system. By taking approximate weights we choose the motor rating. to initiate this project's hardware in the seventh semester ,we fabricated the frame for the machine. We choose aluminum as the material because it cheaper, stronger and reliable comparing with carbon fiber. The remaining works of the project will be done in the eighth semester. It includes the purchasing of the components, its testing, make practice for seed sowing.

#### REFERENCES

- [1] SAHAY (1990), Principals of Agricultural Engineering (2005), Volume 1, Text book published by Jain brothers, New Delhi, India.
- [2] International Journal of Emerging Technology & Research Volume 1, Issue 3, Mar-Apr, 2014 (www.ijetr.org) ISSN (E): 2347-5900 ISSN(P): 2347-6079“Automatic Seed Planter Punching Type”
- [3] Dr. HAJILAL M.S Department of Farm Power Machinery and Energy (FPME) Kelappaji college of Agricultural Engineering & Technology, Thavannur.
- [4] Dr. JAYAN P.R, Associate Professor. Kelappaji college of Agricultural Engineering & Technology, Thavannur.
- [5] Dr. SASIKALA D, Associate Professor Head of the Department of Irrigation and Drainage Engineering (IDE). Kelappaji college of Agricultural Engineering & Technology, Thavannur.
- [6] Dr. P K SURESHKUMAR Associate Professor Dept. of Ag.Engg College of Horticulture, KAU Vellanikkara, Thrissur.