

Development of a Cell Phone based Vehicle Remote Control System using Solar Power

D.Naga¹ M.Ramesh²

¹M.Tech. Student ²Associate Professor

^{1,2}Department of Electronics and Communication Engineering

^{1,2}Jyothishmathi College of Engineering and Technology

Abstract— This paper presents the technical construction of a standalone vehicle controlled by GSM communication network. The designed GSM based solar powered vehicle could be operated from almost anywhere under GSM network which is powered by solar energy using 5 watt photo voltaic (PV) panel, stored in 3 similar 4V rechargeable batteries. The operation commences with a call generated from a cell phone which is auto received by another phone stalked in the vehicle motor driver. In the course of a call, if any of the buttons, 2, 4, 6 or 8, is pressed a tone corresponding to the button pressed is heard at the other end of the transmission which is called Dual Tone Multiple Frequency (DTMF) tone. The received tone in the cell phone at vehicle end is processed by a set of relays. These relayed signals are sent to the motor driver IC (L293D) which drives the motor forward, reverse, right or left. Most importantly as the car will be running by solar energy, so the vehicle can be sent to a long distance not worrying about the charge of the battery, since it accumulates the greater portion of the energy required from the external PV panel that absorbs and converts sunlight to generate the driving power, though there will be DC battery as a backup.

Key words: Solar Vehicle, Remote Controlled Transport, Solar Robot, GSM based Remote

I. INTRODUCTION

A remote control vehicle is typically defined as any mobile device that is controlled by a means that does not restrict its motion with an origin external to the device. This is often a radio control device, cable between control and vehicle, or an infrared controller. A remote control vehicle (RCV) differs from a robot in that the RCV is always controlled by a human and takes no positive action autonomously [2]. One of the key technologies which underpin this field is that of remote vehicle control. It is vital that a vehicle should be capable of proceeding accurately to a target area; maneuvering within that area to fulfill its mission and returning equally accurately and safely to base [1].

The first general use of radio control systems in models started in the late 1940s with single channel self-built equipment; commercial equipment came soon thereafter. Initially remote control systems used escapement, (often rubber driven) mechanical actuation in the model [23]. Commercial sets often used ground standing transmitters, long whip antennas with separate ground poles and single vacuum tube receivers [5]. The first kits had dual tubes for more selectivity. Such early systems were invariably super regenerative circuits, which meant that two

controllers used in close proximity would interfere with one another [6].

II. DESIGN AND CONSTRUCTION

In this project the vehicle is attached with a mobile phone under GSM communication network which is controlled by a user mobile phone. With the help of user mobile phone we can move the vehicle in desired direction as per our requirement. This project is constructed from a very compact dual tone multi-frequency (DTMF) based decoder, and the GSM network controlled vehicle organizes the switching from the decoded and power switching device for controlling the motor drive of the vehicle using two cell phones.

We know RC (Remote Controlled) cars or vehicle do not have a high range of wireless network. This means that the operator has to be in touching distance to the receiver of the vehicle. Thus it is clear that a remote controlled vehicle cannot be applied for an array of duty due to its lacking of controlling range. This is where GSM controlled vehicle steps in. Using two GSM able phones we can create a controlling mechanism for the vehicle. Here we do not have to worry about the range for operation, if sensors such as IR sensors and camera or 3G enabled mobile phones are used, as most of the world is under the assortment of GSM network [9]. By using this prospect we can take this vehicle and turn it for human benefits. These vehicles can be used as firefighting robots, battle vehicles or applied in vast places where it's not possible or dangerous for any human being to go.

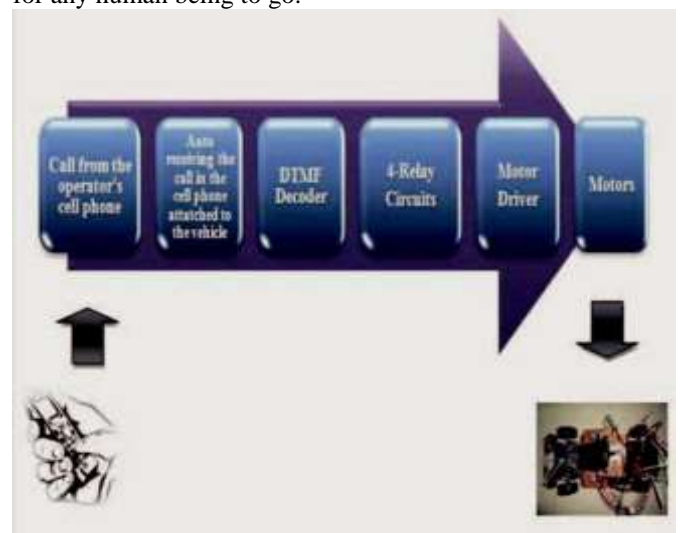

Fig. 1: Block diagram of GSM network controlled vehicle.

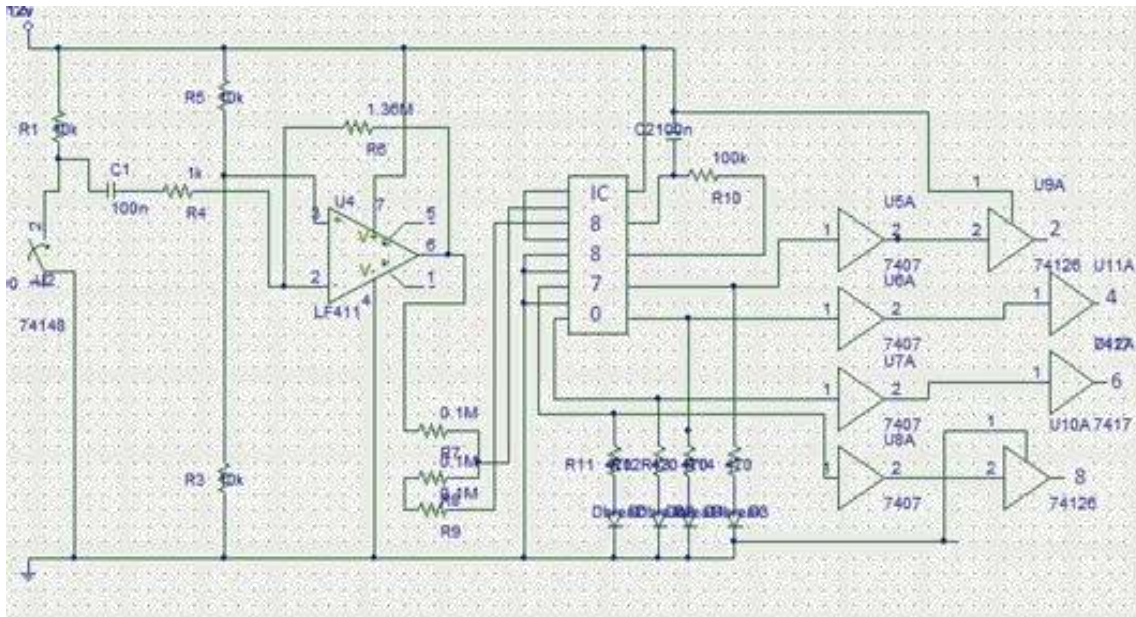

Fig. 2: Circuit diagram of the DTMF operation

The solar powered standalone vehicle was controlled by a mobile phone that made calls to the mobile phone attached to the vehicle. In the course of the call if any button was pressed, pulse sound corresponding to the pressed button was heard at the other end of the call. This tone is called dual tone multi frequency (DTMF) [3]. The vehicle received this DTMF tone with the help of phone

stacked in the vehicle. The connection between the cellphone and the decoder is made with the help of a universal 3.5mm audio jack. The received tone was processed by the relays Q1, Q2, Q3, and Q4. The relays are wired such that for a particular pulse from the DTMF voltage will pass through only one relay and the other three relays are closed [4].

When no buttons is pressed	Button '1' is pressed and held	Release button '1'	Button '2' is pressed and held	Release button '2'	Button '0' is pressed and held
Logic 0	Logic 1	Logic 0	Logic 1	Logic 0	Logic 1
Q ₄ : 0	Q ₄ : 0	Q ₄ : 0	Q ₄ : 0	Q ₄ : 0	Q ₄ : 1
Q ₃ : 0	Q ₃ : 0	Q ₃ : 0	Q ₃ : 0	Q ₃ : 0	Q ₃ : 0
Q ₂ : 0	Q ₂ : 0	Q ₂ : 0	Q ₂ : 1	Q ₂ : 1	Q ₂ : 1
Q ₁ : 0	Q ₁ : 1	Q ₁ : 1	Q ₁ : 0	Q ₁ : 0	Q ₁ : 0

Table 1: Logic Table for Turn on and Turn off for the Set Of relays [26]

L: Low (Logic 0) H: High (Logic 1)

Thus it's possible for the motor drives to drive the motors for forward or backward motion or make a turn. The mobile that makes a call to the mobile phone stacked in the vehicle acts as a remote [8]. The DTMF decoder and the switching circuit is designed to permit a digital signal processing device control high power external loads by issuing commands encoded as audio DTMF signals. The relays direct the overall operation of the DTMF decoder to perform the actual DTMF audio tone pair decoding. When a valid tone pair is detected by the DTMF decoder, an interrupt is signaled the tone pair code from the decoder and places the symbol in an internal quell for further processing [5]. DTMF signaling is used for telephone signaling over the line in the voice-frequency band to the call switching center [5]. The version of DTMF used for telephone dialing is known as touch-tone. DTMF assigns a frequency (consisting of two separate tones) to each key so that it can easily be identified by the electronic circuit. The signal generated by the DTMF encoder is the direct algebraic summation, in real time, of the amplitudes of two sine (cosine) waves of different frequencies, i.e., pressing '5' will send a tone made by adding 1336 Hz and 770 Hz to the other end of the mobile [1]. The tones and assignments in a DTMF system are shown in Table II.

Dig	Low	High	D ₄	D ₃	D ₂	D ₁	D ₀
-----	-----	------	----------------	----------------	----------------	----------------	----------------

it	Frequency (in Hz)	Frequency (in Hz)					
1	697	1209	H	L	L	L	H
2	697	1336	H	L	L	H	L
3	697	1477	H	L	L	H	H
4	770	1209	H	L	H	L	L
5	770	1336	H	L	H	L	H
6	770	1477	H	L	H	H	L
7	852	1209	H	L	H	H	H
8	852	1336	H	H	L	L	L
9	852	1477	H	H	L	L	H
0	941	1209	H	H	L	H	L
*	941	1366	H	H	L	H	H
#	941	1477	H	H	H	L	L
A	697	1633	H	H	H	L	H
B	770	1633	H	H	H	H	L
C	852	1633	H	H	H	H	H
D	941	1633	H	L	L	L	L
An	L	0	0	0	0
y	L	0	0	0	0

Table 2: DTMF Data Output [24]

Here, the relays are switches that open and close circuits electronically. Relays control one electrical circuit by opening and closing contacts in another circuit. When a

relay contact is normally open (NO), there is an open contact when the relay is not energized. When a relay

contact is Normally Closed (NC), there is a closed contact when the relay is not energized.

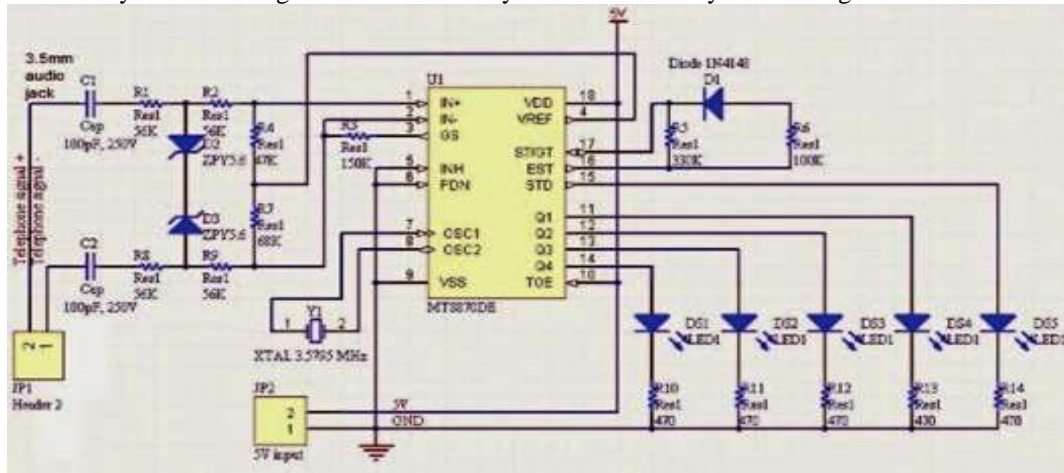

Fig. 3: Connection diagram of DTMF circuit

In either case, applying electrical current to the contacts will change their state.

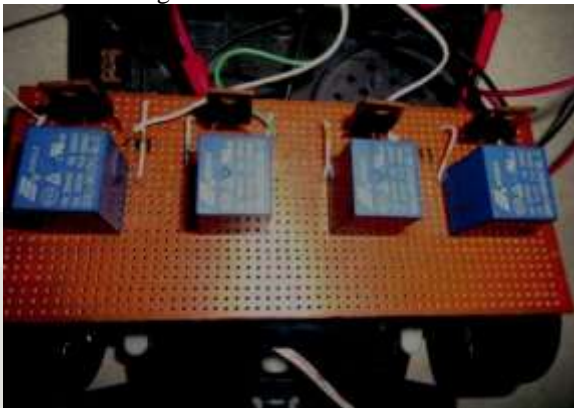

Fig. 4: Relays implemented on vero board

Relays are generally used to switch smaller currents in a control circuit and do not usually control power consuming devices except for small motors and Solenoids that draw low amps. Nonetheless, relays can "control" larger voltages and amperes by having an amplifying effect because a small voltage applied to a relays coil can result in a large voltage being switched by the contacts [21].

To charge the cells that used in the whole project an external solar charged controlled was used. The cell that was used was a mono 5watt power cell with rated voltage of 17V. A charge controller, or charge regulator is basically a voltage and/or current regulator to keep batteries from overcharging [22]. It regulates the voltage and current coming from the solar panels going to the battery. Most "12 volt" panels put out about 16 to 20 volts [13]. Most batteries need around 14 to 14.5 volts to get fully charged [12].

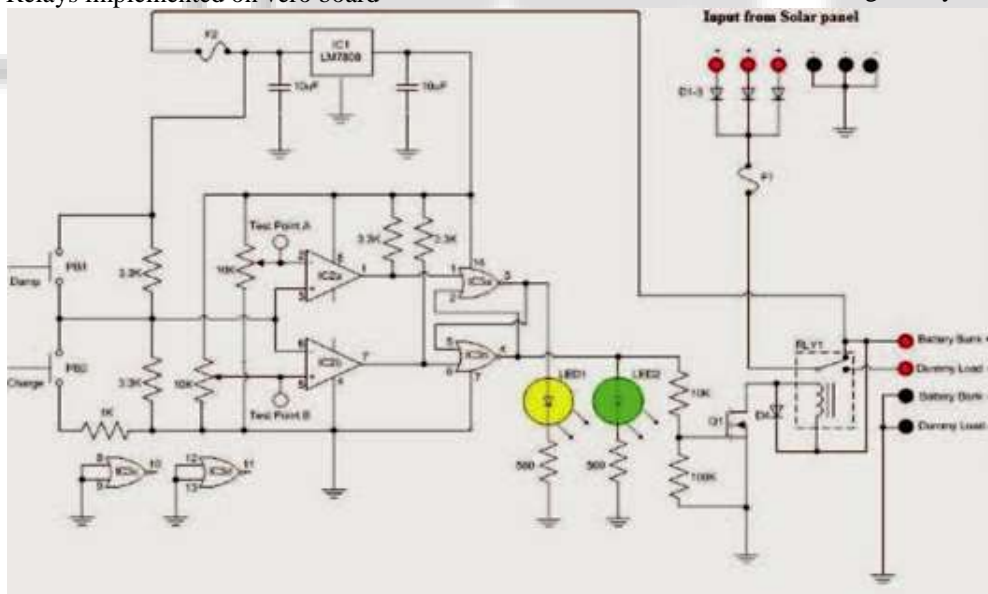

Fig. 5: Solar charge controller circuit diagram

A photovoltaic cell consists of a light absorbing material which is connected to an external circuit in an asymmetric manner. Charge carriers are generated in the material by the absorption of photons of light, and are driven towards one or other of the contacts by the built-in spatial asymmetry. This light driven charge separation establishes a photo-voltage at open circuit, and generates a photocurrent

at short circuit. When a load is connected to the external circuit, the cell produces both current and voltage and can do any electrical work [14].

Module Type- Mono 5W	
Dimensions (mm)	244 X 288 X 17
Maximum Power (P _{max})	5W
Tolerance of (P _{max})	0±3%

Rated Voltage (U_{mpp})	17V
Rated Current (I_{mpp})	0.29A
Open Circuit Voltage (U_{oC})	21.6V
Short Circuit Voltage (V_{sc})	0.34V
Maximum System Voltage	600V
Weight (Kg)	0.75

Table 3: Table For Specifications Of The Solar Cell [27]

After numerous testing and running of the batteries a table was constructed of the time required for charging and discharging of the batteries using the solar charged panel.

Test Run	Charging	(3 separate 4V batteries)	Discharging	Running Condition	Time of Day
1		130 Min		120 Min	9:00
2		125 Min		125 Min	11:00
3		115 Min		122 Min	14:00
4		170 Min		120 Min	16:30
5		210 Min		122 Min	18:00

Table 4: Recorded Charging And Discharging Durations

Outputs from the relays are fed to inputs of motor drivers respectively to drive two geared DC motors. The relay sends voltage to drive the DC motors. Drivers are required for motor rotation. The L293D is a quad, high-current, half-H driver designed to provide bidirectional drive currents of up to 600mA at voltages from 4.5 V to 36V [20].

Table 5: Operation from DTMF Decoder to Relay [25]

Button pressed	Output of decoder	Input to Relay	Output from Relay	Action Performed
2	0X02 0000010	0XFD 11111101	0X09 00001001	Forward Motion
4	0X04 0000100	0XFB 11111011	0X05 00000101	Left Turn Right Motor Forward Left Motor Back Warded
6	0X06 00000110	0XF9 11111001	0X0A 00001010	Right Turn Right Motor Back Warded Left Motor Forwarded
8	0X08 00001000	0XF7 11110111	0X06 00000110	Backward motion

The driver makes it easier to drive the DC motors. The L293D consists of four drivers. Pins IN1 through IN4 and OUT1 through OUT4 are input and output pins, respectively, of Driver 1(D1) through Driver 4(D4). drivers 1 and 2, and drivers 3 and 4 are enabled by enable pin 1 (EN1) and pin9 (EN2), respectively. When enable input EN1 (pin1) is high, drivers 1 and 2 are enabled and the outputs corresponding to their inputs are active. Similarly, enable input EN2 (pin9) enables drivers 3 and 4.

III. METHOD OF STUDY

The information about designing the circuits were collected from many sources i.e. books, papers, websites etc and was studied well to get idea [18]. We have studied on different kind of remote controlled vehicle and also the use of GSM communication network. Photovoltaic panel was implemented to recharge the rechargeable battery. And also a solar charge controller is designed and implemented to regulate the power flowing from a photovoltaic panel into a rechargeable battery. The solar charge controller features

The three separate 4V batteries were connected to our solar charge controller circuit and were left to charge on the roof of a high rise building during day time. This was done for few days and the corresponding charging time for the battery to get fully charged was recorded at different time of the day. To record the discharge reading of the batteries when all our components were connected the system was turned on and was used until the batteries ran out of full charge. The time required for the batteries to lose full charge was also recorded. All these recorded values were placed in Table IV.

easy setup with one potentiometer for the float voltage adjustment and an equalize function for periodic overcharging.

The steps involved to finish this project are listed below:

- 1) Step 1 Collecting the information about the topic from many sources like books, papers, websites, etc
- 2) Step 2 Choosing equipments available for the study and developing idea about cell phones to act as a remote controlling device
- 3) Step 3 Designing the circuit using circuit stimulating software like PSpice
- 4) Step 4 Implementing the circuit in breadboard, and then in vero board to minimize the size of the circuit
- 5) Step 5 Observing the output signal by varying the input signal and recording the charging and discharging time
- 6) Step 6 Reducing the error The performance of the vehicle was observed carefully. Thus the study of the project was successfully completed overcoming the limitations to some extent.

IV. COMPLETED SYSTEM & SUGGESTED MODIFICATION

Previously some researches involved vehicles which could be remotely controlled, but it should have been kept under a range where it could be supervised. Here as we are willing to make it cell phone based remote control vehicle it can be operated almost everywhere if GSM network exists. Moreover it can charge its battery by its own by the use of solar panels so it is itself a standalone system. Since the car will be running



Fig. 6: Implemented GSM controlled vehicle

by solar energy, the vehicle can be sent to a long distance not worrying about the charge of the battery, since it will try to gather most of the energy by solar power, though there will be a DC battery as backup [17]. As it will be dependent on solar energy it is quite obvious that it is an eco-friendly project. In addition the charge controller will make the project even more efficient.

On the other hand, for the operation of this system always two cell phones are required so every time the remote has to dependent on another cell phone that has to connected and stacked to the chassis of the vehicle and by default it was assumed that the cell phone's number is a secured one, which is only known by the system.

A prototype of the remote system controlling has been implemented in this project. Although the implementation is just a simple automatic vehicle utilizing renewable energy as its power source, it may be a pathway for more such researches.

Evaluating this project and thesis paper, it is clearly noticeable that this project has opened the window for enormous future researches in this field for the next researchers.

A. Substituting the 2G GSM cell phone with 3G handset

3rd Generation or 3G is the generic term used for the next generation of mobile communications systems. 3G technology is commonly used in smart phones, where a strong emphasis is put on internet and multimedia services while its predecessor, second generation or 2G technology emphases mostly on voice applications like talking, call waiting, etc. 3G technology has two major advantages over 2G which enables always connectivity to internet [16]. Hence finally it can be stated/covered that replacing the existing handset with a 3G one will not only extends operation of the developed circuit but will also enable some more additional features to be employed alongside the present one.

B. Modification in the System Design

This project can also be made perfect by means of conducting three simple modifications in this existing circuit:

1) *Replacing the DTMF Decoder with DTMF Transceiver:*
Future researchers can implement this assignment by substituting the DTMF Decoder IC 8870 by a DTMF Transceiver IC 8880, allowing the system to generate a DTMF tone by itself [7]. If an additional alarm circuit along with sensors is implemented along with the existing one, the system will then be able to notify the user when an alarm initiates via calling a fixed number.

2) *Password Protection:*

In order to prevent unauthorized access of this robot, the project can be employed by means of password protection. In case of one interested in implementing the present circuit, the cell phone connected should be password protected [10].

3) *Deploying a Camera:*

Installing a camera with the current system will enable the vehicle to operate in difficult territories which are either out of range of human reach or are hazardous for human life [11].

C. Implementation of PWM Charge Controller

Future researchers can work out to determine the possibility of implementing a Pulse Width Modulation (PWM) based controller circuit for managing the charging and discharging of the battery not only using photovoltaic energy but also wind energy [15].

D. Modifications in the System Operation

The operation of the system can easily be modified and this vehicle can be used for variety of purposes. Conducting some adjustments in the system design and body will enable this vehicle to serve as remote control robot performing other wide range of operations. Some of such operations are highlighted below:

1) *Remote Control Racing Vehicle:*

Robotic Race Cars can easily be designed via some simple modifications in this design. The cars will travel in a pre-designed track and users will be in command of the navigation of the car.

2) *Bomb Detector Vehicle:*

Future researchers can easily modify this vehicle and use it as bomb detector robot. It can be done efficiently by implementing a program to trace the exact positions of bombs on a pre-designed map. The robot will be designed to sense bombs in a remotely controlled way, and user will navigate the robot and locate the landmines and update information into the program's database.

3) *Remote Control Fire Fighter Device:*

This project can be modified easily and be implemented as a prototype model for fire fighter robot. The microcontroller operated robot will move through a structure, detect fire and then extinguish it with the help of blower.

E. Replacing the Relay Logic Circuit with a Micro-Controller

This circuit is constructed using a set of relays whose function solely is to transfer the DTMF tone from the cell phone to the motor driver IC, L293D. Upcoming researchers can execute this project replacing the relays with a microcontroller which is a small integrated circuit with a microprocessor, memory and programmable input / output support [19].

V. CONCLUSION

The key purpose was to develop a circuit that can drive an electric vehicle in any directions using GSM based cell phones as a distant controller, and the trial approached has been a success. This system utilizes a renewable energy based battery management system and a GSM technologically operated mobile phone for its operations. The second part of this project highlights on deploying a battery management system using renewable photovoltaic energy as its power source from which the system can charge its batteries using solar panels as a standalone system. This system can be a test-bed for any future projects and or appliances interested to work with both renewable energy and remote control communication technology together.

REFERENCES

- [1] T. M. Ladwa, S. M. Ladwa, R. S. Kaarthik, A. R. Dhara and N. Dalei, "Control of Remote domestic System

- using DTMF”, International Conference on Instrumentation, Communications, Information Technology, and Biomedical Engineering (ICICI-BME), Bandung, Indonesia, 2009, pp. 1-6.
- [2] D. Heß, C. Röhrig. “Remote Controlling Technical Systems Using Mobile Devices”, IEEE International Workshop on Intelligent Data Acquisition and Advanced Computing Systems: Technology and Applications, Rende (Cosenza), Italy 21-23 September 2009, pp.625-628.
- [3] M. Callahan Jr, “Integrated DTMF Receiver,” IEEE Transactions on communications, vol. 27, pp. 343-348, February, 1979.
- [4] Y. C. Cho and J. W. Jeon, “Remote Robot control System based on DTMF of Mobile Phone” IEEE International Conference INDIN 2008, July 2008.
- [5] R. Sharma, K. Kumar, and S. Viq, “DTMF Based Remote Control System,” IEEE International Conference ICIT 2006, pp. 2380-2383, December 2006.
- [6] S. Selman, R. Paramesran, “Comparative Analysis of Methods Used in the Design of DTMF Tone Detectors” IEEE International Conference on Telecommunications and Malaysia International Conference on Communications, 14-17 May 2007, Penang, Malaysia.
- [7] R. C. Luo, T. M. Chen, and C. C. Yih, “Intelligent autonomous mobile robot control through the Internet,” IEEE International Symposium ISIE 2000, vol. 1, pp. 611, December, 2000.
- [8] C. K. Das, M. Sanaullah, H. M. G. Sarower and M. M. Hassan, “Development of a cell phone based remote control system: an effective switching system for controlling home and office appliances”, International Journal of Electrical & Computer Sciences IJECS, vol. 9 No: 10 pp3743, 2010
- [9] V. Hachenburg, B. Holm and J. Smith, “Data signaling functions for a cellular mobile telephone system”, IEEE Trans Vehicular Technology, vol. 26, #1 p. 82, 1977
- [10] Lagura, J. L. R., Pascual, M. C. G., Rabadan, R. J. R., & Tabac, A. G. (2004) “Microcontroller- based aid for the blind in reading mobile phone messages using braille system”, Undergraduate Thesis. De La Salle University Manila.
- [11] H. Haldun GÖKTAS, Nihat, “A Cellular Phone Based Home / Office Controller & Alarm System” DALDAL Gazi University Technical Education Faculty, 06500, Besevler, Ankara, TURKEY
- [12] Nelson, Jenny, “The Physics of Solar Cells”, London: Imperial College, 2003. Print
- [13] N. C. Bhowmik, Bangladesh Renewable Energy Report, APCTT-UNESCAP, 2012
- [14] R. Subarkah, Belyamin, “Improved Efficiency Solar Cells with Forced Cooling Water”, retrieved on 16/10/2011.
- [15] A. Z. Alkar, U. Buhur, "An Internet Based Wireless Home Automation System for Multifunctional Devices," IEEE Consumer Electronics, vol. 51, no. 4, pp. 1169-1174, 2005.
- [16] R. Shahriyar, E. Hoque, S. M. Sohan, I. Naim, M. M. Akbar, and M. K. Khan, “Remote Controlling of Home Appliances using Mobile Telephony”, International Journal of Smart Home, Vol. 2, No. 3, July, 2008.
- [17] K. Reddy, F. Althobeti, Dr Md A. Hussain and R. Reddy, “GSM-Controllable Power Switch System for Industrial Power Management”, International Journal of Engineering Trends and Technology, August 2011
- [18] T. Kubik and M. Sugisaka, “Use of a Cellular Phone in Mobile Robot Voice Control”, Proceedings of the 40th SICE Annual Conference. International Session Papers, Nagoya, 2001, pp.106-111.
- [19] http://www.newworldencyclopedia.org/entry/Remote_control [May 5, 2013]
- [20] http://www.extremeelectronics.co.in/avrtutorials/pdf/avr_tutorial7---motor-control.pdf [May 15, 2012]
- [21] <http://electronics.howstuffworks.com/relay1.htm> [Sep 5, 2012]
- [22] <http://www.solar-electric.com/solar-charge-controller-basics.html> [Sep 15, 2012]
- [23] <http://www.studymode.com/subjects/historical-background-of-the-ntc-radio-control-office-page2.html> [July 11, 2012]
- [24] <http://www.datasheetarchive.com/MT8870-datasheet.html> [May 7, 2012]
- [25] <http://www.dattalo.com/technical/theory/dtmf.html> [June 19, 2012]
- [26] <http://www.omega.com/manuals/manualpdf/M1906.pdf> [May 19, 2012]
- [27] http://www1.eere.energy.gov/buildings/residential/pdfs/rerh_pv_guide.pdf [Sep4, 2012]