

# Design, Development and Fabrication of a Compact Harvester

Laukik P. Raut<sup>1</sup> Vishal Dhandare<sup>2</sup> Pratik Jain<sup>3</sup> Vinit Ghike<sup>4</sup> Vineet Mishra<sup>5</sup>

<sup>1</sup>Assistant Professor <sup>2,3,4,5</sup>Student

<sup>1,2,3,4,5</sup>Department of Mechanical Engineering

<sup>1,2,3,4,5</sup>GHRCE, Nagpur, India

**Abstract**— This machine targets the small scale farmers who have land area of less than 2 acres. This machine is compact and can cut up to two rows of soybean plant. It has cutting blades which cut the crop in a scissoring type of motion. It runs on diesel engine of 3HP, this power from engine, is provided through pulley and gear box arrangement to the cutter. A collecting mechanism is provided for the collection of crops to one side after cutting. This mechanism is also powered by pulley arrangement. This compact harvester is manufactured using locally available spare parts and thus, it is easily maintainable. This harvester might be the solution to the problems faced by a small scale farmer regarding cost and labour implementation. After testing this machine in farm it is found that the cost of harvesting using this harvester is considerably less as compare to manual harvesting.

**Key words:** Harvester, reaper, scissoring action etc

## I. INTRODUCTION

Recently Vidarbha has seen a shortage of skilled labor available for agriculture. Because of this shortage the farmers have transitioned to using harvesters. These harvesters are available for purchase but because of their high costs, they are not affordable. However, agriculture groups make these available for rent on an hourly basis. But the small holding farm owners generally do not require the full-featured combine harvesters. Also, these combine harvesters are not available in all parts of rural Vidarbha due to financial or transportation reasons. Thus, there is a need for a smaller and efficient combine harvester which would be more accessible and also considerably cheaper. The mission is to create a portable, user-friendly and low cost mini harvester.

These problems gave the basic idea about what was required in the current situation. The idea was to create a machine which is cheap and will reduce the labour required to harvest crops. This machine has the capability and the economic value for fulfilling the needs of farmers having small land holdings (less than 2 acres). This machine is cost effective and easy to maintain and repair for the farmers.

### A. Background:

This section highlights the present state of agricultural farm machinery and equipment and land holding which determine agricultural productivity and production.

#### 1) Agricultural Farm Machinery and Equipment:

Manual labour takes time and is not effective as they can work for 3-4 hours at a stretch. Even if the land holding is small, it takes two or three days to completely harvest the soybean crop. Also the planting is not done with proper care. Hence the crops are strewn with a lot of non required plants, which grow with the soybean. So to harvest these unwanted crops along with the soybean is a tedious work. Given below is the traditional method of harvesting soybean.



Fig.1 Manual Harvesting

The focus of this project is to make a combined harvesting and collecting machine for the small scale farmers of India who have land holdings less than two acres, to harvest grains more efficiently.

The level of mechanization has been increasing steadily over the years because of the joint efforts made by the Government and the private sector. As a result of different programs implemented by the Government of India over the years, the total farm power availability is estimated to have increased from 0.295 kW/ha in 1971-72 to 1.71 kW/ha in 2010-11.

#### 2) Land Holding:

Even though the adoption of farm mechanization is increasing in India, it is mostly region specific. Farm mechanization has a very low growth rate in regions such as hilly and sloppy land. The decreasing trend in operational land holding is also obstructing the growth of agricultural mechanization. High costs of machines and maintenance, non-availability of appropriate agricultural machines and equipment that cater to and suit the requirements of small scale farms, non-availability and or difficulty in getting bank credit and small land holding are some of the factors that hinder farm mechanization and force farmers to follow the traditional ways of agricultural operations. The use of farm machinery is also dependent on infrastructure and services available in the rural areas. India continues to be fed by its marginal and small farmers. Their holdings (those below two hectares) taken together account for 84.97% of total holdings in 2010-11 compared with 83.29% in 2005-06; the combined area under these myriad farmed plots is 44.31% of the country's total farmed area (it was 41.14% in the 2005-06 census).

## II. LITERATURE REVIEW

Christopher Molica's [1] project was done by the students of Worcester Polytechnic Institute. They have created a small scale harvester which was combined reaper and binder. This machine was developed concerned to the small scale grain growers.

Yuming Guo's [2] paper describes the relation between the stalk strength and the cutting force that is required for cutting the soybean. The paper was helpful in guiding on the calculations front. This paper briefly

describes the strength of various crops and compares it with the soybean. This relationship helps in giving a rough idea about the cutting speed required to cut the crop.

N. S. L. Srivastava [3] checked in the interests of the farmers and the problems they face while harvesting and maintaining the agriculture field. This paper was an in depth study of the farming conditions of the farmers and their basic problems.

Indian Government Analysis [4] was the survey done by Indian Government in the fiscal year of 2012-13. This survey was intended to analyse and collect the data related to the problems and difficulties faced by the Indian farmers.

Asia and Pacific Commission on Agricultural Statistics Twenty-Third Session Siem Reap, Cambodia, 26-30 April 2010 [5] was intended to discuss the characteristics of small scale farmers across Asia. This commission identifies the problems faced, the average land holdings and the average income of the small scale farmers.

Dr. S.D. Kulakarni Central Institute of Agricultural Engineering (CIAE) Bhopal [6] discusses the various problems that the farmers face at the peak season of the harvesting. It specifically limits its results toward the labour scarcity in India, specifically in the peak harvesting season.

### III. METHODOLOGY

With the demand for the grains on rise, the aim was to fabricate affordable reaper collector for increasing the economy of small scale farmers. For the fulfilment of this aim, it is decided to follow following steps:

- Interview the local farmers who have small scale land holding and enquire about the harvesting practices and the crops produced and emerging trends in crop harvesting.
- Interview agricultural equipment manufacturers to get information about various equipments that are available and are in demand.
- Refer various international papers in small scale harvesters produced earlier.
- Design of reaper collector harvester.

#### A. Conducting Interviews with Farmers:

The design of this machine was to be based on the demand for a compact and affordable harvester. This demand could have been seen only with personal interaction with small scale farmers. Most of the farms in or near Nagpur city are small scale farms. The purpose of this visit was to see and enquire about the harvesting machines that are being used by the farmers. The following questions were asked to the farmers:

- [1] What are the machines available for harvesting?
- [2] What do these machines cost?
- [3] Are these machines feasible for small scale farms?
- [4] What are the traditional techniques used for harvesting?
- [5] Can a small reaper collector be able to satisfy the increasing prices of labour?
- [6] What is the labour cost for harvesting, as it is the most labour intensive work?

These questions gave the basic idea about the situation of small scale farmers. We came to know the needs and the requirements of the farmers.

#### B. Consulting Agricultural Machines Manufacturer:

We consulted the Padgilwar Agro Industries Limited about the manufacturability for the harvester. Padgilwar Agro Limited have been producing agricultural equipments since 1960. We interrogated them about to get the basic idea about the manufacturing equipments that are available. The following questions were asked to get a generalised idea about the various types of manufacturing equipment.

- [1] What are the equipments manufactured for the farmers today?
- [2] How many of these manufactured equipments are available for small scale farmers?
- [3] Why are there no small scale harvester collector manufactured for farmers?
- [4] Why does the company consult local farmers while designing a new product?
- [5] What difficulties are faced while designing a machine based on the needs of the farmers?

All these questions were recorded and notes were collected for further study.

#### C. Archival Reports:

The past data bases like Google scholar, Google Patents and relevant papers for small scale grain harvesters were examined. The purpose was to gain an insight into what were the previous researches done on the topic and what were the implications of those designs.

#### D. Design of Reaper Collector Harvester.

The data that obtained from the interviews and research is used to finalize the specifications of grain machine; this included general size and functionality. On the basis of information collected from farmers, manufacturer and researchers the following objectives being set;

- Designing a compact machine.
- Decrease the cost of machine.
- Decrease the labour requirement for harvesting.
- Decrease the efforts required for harvesting.
- Using proper collecting mechanism to increase the efficiency of harvesting.

So considering these points related to harvesting an attempt is made to design and fabricate such equipment which will able to perform the operations more efficiently and also will results in low cost.

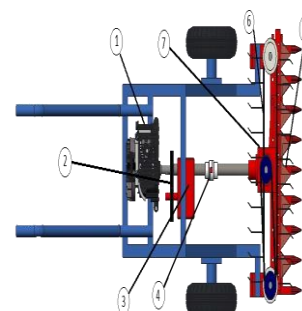

Fig. 2: Top view of harvester

1. Diesel engine 2. Belt Drive 3. Spur gearbox 4. Coupling
5. Cutter assembly 6. Collecting belt 7. Bevel gearbox

The machine performs two operations namely 'Harvesting and collecting'. There are two cutter blades; one is moving and another is stationary. The slider crank mechanism is used to convert rotary motion to linear

sliding motion. Scissoring action is obtained due to reciprocating movement of cutter blade over stationary blade is used to cut the crops.

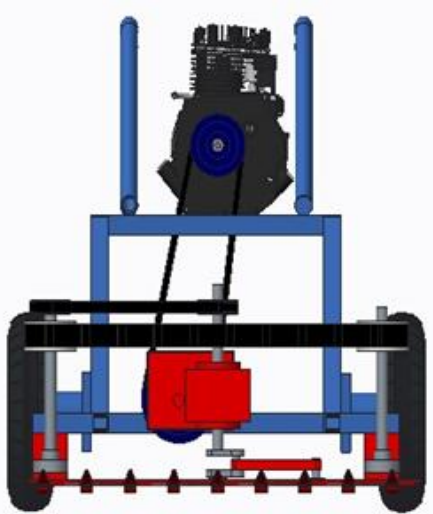

Fig. 3: Front view of Harvester

#### IV. WORKING

It is a walk behind type of harvester which is powered by the 2.2Kwatt, 3000 rpm diesel engine. With the help of V-belt, drive power is transmitted to gearbox. As the required rpm at cutter is as less as 200 rpm, a spur gearbox and a bevel gearbox is used. Here bevel gear is used to change the direction of drive in the gear system by  $90^\circ$ . One end of this output shaft is connected to slider crank mechanism which converts rotary motion of shaft into reciprocating motion of cutter blade. Reciprocating cutter blade slides over fixed blade and creates scissoring action responsible for cutting the crops. Collecting mechanism consist of flat belt with collecting plates bolted on it. Collecting belt simply carry cut crops sideways.



Fig. 4: CAD model of Harvester

#### A. Detailed Description of Parts:

##### 1) Main frame:



Fig. 5: Main frame

Firstly, the frame of the harvester with the dimension  $400 \times 800 \times 400$  ( $l \times b \times h$ )  $\text{mm}^3$  is fabricated. The mild steel angle section is used to build the frame. The frame is light and strong enough to sustain weight of diesel engine. After frame is developed it was time for engine mounting.

##### 2) Diesel Engine:

Diesel engine of 2.2 KW, 3000 rpm and it rope start type of engine is used. Diesel engine is selected because diesel engine has good efficiency, power and fuel is easily available at ruler areas.



Fig. 6: Diesel Engine

##### 3) Belt Drive:

The belt drives primarily operate on the friction principle. i.e. the friction between the belt and the pulley is responsible for transmitting power from one pulley to the other. In other words the driving pulley will give a motion to the belt and the motion of the belt will be transmitted to the driven pulley. V- Belts are used because its advantages over flat belts in compact transmission design. Engine power is transmitted to the spur gearbox with the help of belt drive.



Fig. 7: Belt drive (drive from engine to spur gearbox)

4) *Spur Gearbox:*



Fig. 8: Spur gearbox

For compact transmission design it is desirable to use gears. It is very compact, takes very less space which is required in this machine. The main advantage of gear drive is that it transmit same velocity ratio and also it is used to transmit a very large power with very good reliable service. Spur gearbox consist of pinion with 19 teeth and gear with 68 teeth.

5) *Coupling:*

A coupling is a device used to connect two shafts together at their ends for the purpose of transmitting power. The output shaft of spur gearbox is coupled with input shaft of bevel gearbox with the help of jaw coupling.



Fig. 9: Coupling

6) *Cutter Assembly:*



Fig. 10: Cutter assembly

Cutter assembly consist of a sliding cutter plate and a stationary cutter plate. The cutters used are of triangular shape. In sliding cutter plate, cutter blade is riveted on 3 mm plate and in stationary cutter plate; cutter blade is riveted on 5 mm plate. The stationary cutter plate can be directly bolted and fixed on frame. Sliding cutter blade is provided with 2 slots of 80 mm on its ends; it allows sliding motion to be in straight line.

7) *Collecting Belt:*



Fig. 11: Collecting mechanism

The collecting belt is used to carry cut crops sideways. Proper collecting of crop is very important to reduce the grain losses during harvesting. Hence implementation of collecting mechanism increases the efficiency of harvesting machinery.

8) *Bevel Gearbox:*

Bevel gearbox is used to change the direction of motion by 90°. This type of gearbox is used because there was a need to transmit power to two mechanisms i.e. slider crank mechanism and collecting mechanism.



Fig. 12: Bevel gearbox

9) *Assembly:*

All the components were brought together and then bolted on the frame. First engine is mounted on the frame using nut and bolts. Then spur gear box is bolted to the frame, and with the help of pulley system engine and spur gear box is connected. Then the bevel and spur gear box is connected together using Loja coupling. This coupling was used because the shafts of both gear boxes were in same line. To the output shaft of the bevel gear box is connected to collecting mechanism using belt-pulley system. To the other end of output shaft of bevel gear box cutting mechanism is connected using crank shaft system.



Fig. 13: Actual Harvester

## V. CALCULATIONS

### A. Power Required to Drive Mechanism:

The power required to drive the compact harvesting machine must be such that

- [1] It must carry variable load during constant running of machine.
- [2] According to studies done on soybean crops the reciprocating speed should be 0.8 to 1.2 m/s.
- [3] Scissoring action is used to cut the crop.
- [4] Speed given to collecting mechanism will be more than the reciprocating mechanism.
- [5] The frame must sustain the weight of engine and gearbox.
- [6] Along with crop strength, strength of miscellaneous items such as weeds stems etc.

So, keeping these objectives in mind, the power required to drive the load is according to the requirement of machine. It must be 2HP to 3HP. So, being on the safer side diesel engine producing power of 3HP is selected.

#### Drive Design

Let,

$N_1$  = Engine rpm

$d$  = Diameter of small pulley

$N_2$  = input to spur gear box

$D$  = Diameter of Large pulley

$N_1 d = N_2 D$

$3000 \times 2.5'' = N_2 \times 6''$

$N_2 = 1250$  rpm

#### Spur gear drive

$T_2$  = Pinion teeth

$N_3$  = output rpm

$T_3$  = gear teeth

$N_2 T_2 = N_3 T_3$

$1250 \times 19 = N_3 \times 68$

$N_3 = 349.26$

#### Bevel gear drive

$T_4$  = Input bevel gear teeth

$T_5$  = output bevel gear teeth

$N_4 = N_3$  = Input rpm to bevel gear

$N_4 T_4 = N_5 T_5$

$349.26 \times 10 = N_5 \times 16$

$N_5 = 218.75$

Final rpm at cutter is 218.75 rpm

#### Belt drive design for Engine

$N_1 = 3000$  rpm

$N_2 = 1250$  rpm

Speed ratio ( $S_r$ ) = 2.4

Service factor for engine = 1.2

Design Power ( $P_d$ ) = 2.2 x 1.2

Belt Section – A/A<sub>x</sub>

Small pulley diameter,  $d = 2.5''$

Large pulley diameter,  $D = 6''$

Centre distance,  $C = 2D = 12''$

Belt Length,  $L = 2C + 1.57 (D + d) + \frac{(D+d)^2}{2C}$

$L = 38.85''$

Minimum length of belt = 38.85''

Thus we used length of the belt as 51''

Power Rating,  $P = 1.13$  KW

Arc of contact factor,  $F_c = 171^0$

Pitch length correction factor,  $F_d = 0.80$

Number of belt required =  $\frac{P_d}{P \times F_c \times F_d} = 2$

Hence 2 belts are required.

Belt drive design for collecting mechanism

Smaller diameter of collecting pulley,  $d_c = 2''$

Larger diameter of collecting pulley,  $D_c = 3''$

Centre distance,  $C = 2D_c = 6''$

Belt Length,  $L = 2C + 1.57 (D_c + d_c) + \frac{(D_c+d_c)^2}{2C}$

Belt length,  $L = 15.93''$

Length of belt used to drive collecting mechanism is 16''

### B. Actual cost of Harvester:

Sr. No	Part Required	Quantity	Price/part (Rs.)	Total cost (Rs.)
1	Engine 3hp 3000rpm	1	10500	10500
2	Spur gear box	1	3500	3500
3	Bevel gear box	1	4500	4500
4	6" pulley x2	1	542	542
5	2" pulley x2	1	294	294
6	4" pulley x1	1	180	180
7	3" pulley x1	1	130	130
8	5" Nylon pulley	3	779	2337
9	Coupling	1	650	650
10	Bearing	15	192	2880
11	Shaft	3	500	1500
12	Wheel assembly	1	2000	2000
13	52" V belt	2	400	800
14	32" V belt	1	250	250
15	Frame Angle 40x40x5 mm	37 kg	54/kg	2000
16	MS plate 16mm,10mm	13 kg	58/kg	750
17	1" dia -Pipe	2	325	650
18	G.I. Sheet	1	250	250
19	Collecting belt	1	300	300
20	Bearing circlips	10	20	200
21	Cutter blade	18	40	720
22	Nut bolts etc			113
23	Color			284
24	Labor charge			1500
25	Engine oil			340
26	VAT charges			3200
Total cost (Rs)				40,370

Table 1: Bill of material

## VI. RESULTS

### A. Comparison of Harvesting Cost by Traditional Method and Our Harvester:

#### 1) Harvesting done by manual process:

Amount paid to the labour for one day = Rs. 250 per labour  
Total number of labour required in general to harvest the 1 acre farm of soybean in a day = 6

Total amount paid to the labour = 6 x 250

= Rs. 1500 per acre in one day

Therefore, total expenditure in one day is = Rs. 1500

#### 2) Harvesting done by machine:

Quantity of diesel require for 0.25 to 0.3 acre = 1 litre

Quantity of diesel require for 1 to 1.2 acre = 4 litre

Cost of diesel per litre = Rs. 65

Total cost of diesel for 1 acre farm for a day =  $4 \times 65 = \text{Rs. } 260$

Amount paid to the labour = Rs. 250 per day

Total expenditure = Total cost of diesel + Amount paid to the labour + Maintenance

=  $260 + 250 + 60$

= Rs. 570 ~ Rs. 600

Amount saved by using the harvester =  $1500 - 600 = \text{Rs. } 900$  per day per acre.

#### B. Analysis of the Forces on The Cutter:

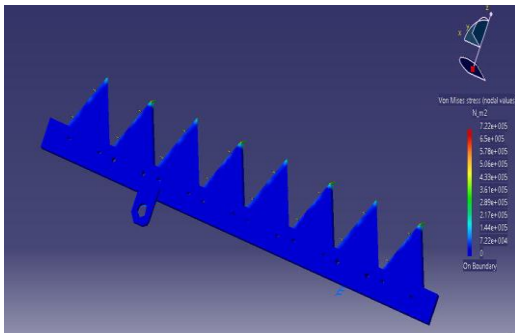

Fig. 14: Force Analysis on the Cutter Blade

The force analysis on the cutter blade is done. A uniformly distributed load of 200N is applied on the cutter blade. This force generated a Von Misses stress of  $7.2 \times 10^5 \text{ N/m}^2$ . The yield strength of the cutter blade is 386MPa. This rendered the cutter safe from the cutting forces.

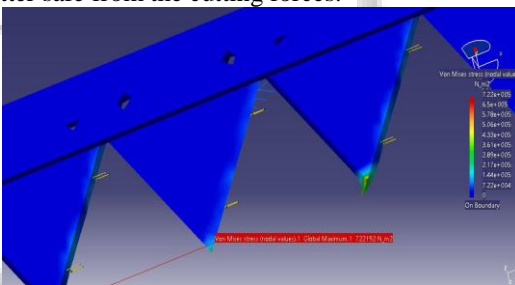

Fig. 15: Force Analysis on the Cutter Blade

## VII. CONCLUSION

The Combined reaper and colleting machine is built to be compact and efficient to cut the crops. The machine was tested on a field to check its cutting capability and efficiency. The test results were successful as the machine performed flawlessly. It can be concluded that the machine is comparatively compact and easy to handle. This machine is able to run of field effortlessly and the efforts of farmers are reduced. The cost of harvesting using this machine is considerably less as compare to manual harvesting. The harvesters available in market are suitable for large farms, so this can be the best machine for the farmers with small land. The success of this machine depends on how the farmers receive this machine as their ally. There are some changes that need to be done on the machine and a final product is to be taken out for sell.

## REFERENCES

- [1] Design of Small-Scale Grain Harvester: A tool for Urban and Pre-urban Growers; Christopher Boyle, Ian Jutras, Christopher Molica, Earl Ziegler.

- [2] Relationship between Stalk Shear Strength and Morphological Traits of Stalk Crops, by Li Liang and YumingGuo.
- [3] Farm power sources, their availability and future requirements to sustain agricultural production, by N. S. L. Srivastava.
- [4] State of Indian Agriculture 2012-13, Indian Government Analysis.
- [5] Asia and Pacific Commission on Agricultural Statistics Twenty-Third Session Siem Reap, Cambodia, 26-30 April 2010.
- [6] Mechanization of Agriculture - Indian Scenario Dr. S.D. Kulkarni, Central Institute of Agricultural Engineering (CIAE) Bhopal - 462 038, India
- [7] Laukik P. Raut et al., 'Design, development and fabrication of agricultural pesticides sprayer with weeder', 'International Journal of Applied Research and Studies', ISSN: 2278-9480, Volume 2, Issue 11 (Nov - 2013).
- [8] Agricultural Research Priority: Vision- 2030 and beyond Sub-sector : Farm Machinery, Irrigation & Water Management and Post-harvest Technology (Engineering aspects)
- [9] <http://india.gov.in/topics/agriculture>
- [10] [http://en.wikipedia.org/wiki/Agriculture\\_in\\_India](http://en.wikipedia.org/wiki/Agriculture_in_India)
- [11] Pressure on farmland The Hindu. 4 February 2014. Retrieved 4 February 2014.