

Gesture Controlled Drone Using a Gyroscopic Sensor Mounted on a Glove

Dr. Aruna Devi M¹ Shibhan Fayaz Ahmed² Rochak Periwal³ Rishabh Raj⁴ Niyaz Naik⁵

¹Associate Professor ^{2,3,4,5}UG Student

^{1,2,3,4,5}Department of Mechanical Engineering

^{1,2,3,4,5}Dayananda Sagar College of Engineering, Bangalore, India

Abstract— We present our implementation of using a motion controller to control the motion of a drone via simple human hand gestures. This can be achieved by building a transmitter and receiver, different from traditional ones, which can be used to easily control a drone. For the implementation of the motion controller, we have used a 2.4GHz Tran receiver and an Arduino Uno. The basic problem with the traditional transmitters/controllers use a multitude of switches, levers, and joysticks to control a drone. The Trans receiver recognizes the hand gestures and relays them onto the ground station. In our implementation, we have written Arduino programming codes to interpret the hand gestures captured by the Trans receiver, and transmit them to control the motion of the drone via these gestures the same gyroscopic glove in the prototype project will be used to control the drone. The BT module is swapped out for a 2.4 GHz Tran receiver for better range, lower latency, and higher bandwidth. The glove sends out a PPM signal to the receiver connected to the drone. The signal consists of values derived from the MPU6050 Gyroscope, which is then converted to a type recognized by the drone, which in this case being the PPM Signal. The Drone is fitted with a flight controller. A Drone Flight Controller (FC), is the heart of a quadcopter and controls most onboard electrical components with the assistance of an Arduino-like microprocessor and an array of sensors. The FC is outfitted with a gyroscope and an accelerometer to calculate its angular velocity and speed and make the optimum calculations required to keep the drone flying. The FC is mounted on the drone and is connected to 4 equally spaced out coreless DC motors responsible for the flight. The Drone is also outfitted with the same 2.4 GHz receiver that receives input from our gyroscopic glove and sends it to the flight controller, which uses that data for its flight. According to the tilt and the acceleration of the glove, the Trans receiver sends appropriate data to the drone for it to change its altitude or tilt and move around

Keywords: Drone, Gyroscopic Sensor

I. INTRODUCTION

A Drone likewise called a quadrotor helicopter or quadrotor is a multirotor helicopter that is lifted and impelled by four rotors. Quadcopters are named rotorcraft, rather than a fixed-wing airplane because their lift is produced by a lot of rotors (vertically situated propellers).

Drones or Quadcopters, by and large, utilize two sets of indistinguishable fixed pitch propellers; two clockwise (CW) and two counterclockwise (CCW). These utilizations free the variety of the speed of every rotor to accomplish control. By changing the speed of every rotor, it is conceivable to explicitly produce an ideal all-out push; to situate for the focal point of push both horizontally and

longitudinally, and to make an ideal absolute torque, or turning force.

Quadcopters contrast from traditional helicopters, which use rotors that can change the pitch of their sharp edges progressively as they move around the rotor center point. At the beginning of the flight, quadcopters (at that point alluded to either as 'quadrotors' or basically as 'helicopters') were viewed as potential answers for a portion of the tenacious issues in vertical flight. Torque-instigated control issues (just as proficiency issues beginning from the tail rotor, which produces no helpful lift) can be disposed of by counter-turn, and the moderately short edges are a lot simpler to build. Various kept an eye on structures that showed up during the 1920s and 1930s. These vehicles were among the main fruitful heavier-than-air vertical take-off and landing (VTOL) vehicles. However, early models experienced poor performance and the last models required an excess of pilot remaining burden, because of poor steadiness augmentation and restricted control authority.

From 2005 to 2010, propels in hardware permitted the creation of modest lightweight flight controllers, accelerometers (IMU), worldwide situating framework, and cameras. This came about in the quadcopter arrangement getting mainstream for little unmanned elevated vehicles. With their little size and mobility, these quadcopters can be flown inside just as outdoors.

At a little size, quadcopters are less expensive and tougher than traditional helicopters due to their mechanical simplicity. Their littler edges are additionally worthwhile because they have less dynamic vitality, decreasing their capacity to cause harm. For little-scope quadcopters, this makes the vehicles more secure for the close association. It is additionally conceivable to fit quadcopters with monitors that encase the rotors, further decreasing the potential for damage. However, as size increments, fixed propeller quadcopters create weaknesses comparative with regular helicopters. Expanding edge size builds its force. This implies changes in cutting edge speed take longer, which adversely impacts control. Helicopters don't encounter this issue as expanding the size of the rotor circle doesn't essentially affect the capacity to control edge pitch. Because of their simplicity of development and control, the quadcopter airplane is now and again utilized as beginner model airplane projects.

Quadcopters are a helpful instrument for college analysts to test and assess new thoughts in various fields, including flight control hypothesis, route, constant frameworks, and mechanical technology. Lately, numerous colleges have demonstrated quadcopters performing progressively complex flying moves. Multitudes of quadcopters can float in mid-air, fly in arrangements, and self-rulingly perform complex flying schedules, for example, flips, shooting through hula circles, and sorting out themselves to fly through windows as a group. There are

various favorable circumstances for utilizing quadcopters as adaptable test stages. They are moderately modest, accessible in an assortment of sizes and their straightforward mechanical structure implies that they can be manufactured and kept up by novices. Due to the multi-disciplinary nature of working a quadcopter, scholastics from various fields need to cooperate to cause huge upgrades to the path quadcopters to perform. Quadcopter ventures are normally joint efforts between software engineering, electrical building, and mechanical designing experts.

Various points of interest lead drones for research and development such as their uses in Military and law enforcement, Photography, Journalism, Drone delivery, Humanitarian operations, Arts, Sports, etc. Over the most recent couple of decades, little-scope unmanned flying vehicles have been utilized for some applications. The requirement for an airplane with more noteworthy mobility and drifting capacity has prompted an ascent in quadcopter look into. The four-rotor configuration permits quadcopters to be generally straightforward in the plan yet exceptionally dependable and flexible. Research is proceeding to build the capacities of quadcopters by making propels in multi-create correspondence, condition investigation, and mobility. On the off chance that these creating characteristics can be consolidated, quadcopters would be fit for cutting edge self-sufficient missions that are right now unrealistic with different vehicles. To appropriately gauge the upsides and downsides of automatons and their utilization, it's essential to look at the two sides of the discussion on their benefits. For example, there are a lot of positive motivations to utilize rambles. Drones are extremely well known because broad communications systems disparage their usefulness and proficiency while catching recordings and pictures. You will see that automatons are basic in touristy territories because of movement blogger advancements. Video bloggers use automatons to additionally build the ubiquity of their recordings; henceforth, elevating the gadget to other new vloggers. Travel organizations use automatons to amplify the travel industry capability of a territory that is well known to all visitors. There are concerns or inconveniences in rambles that influence the client's route schedule. A nearby government unit in some cases confines the utilization of automatons when there is a progressing military clash. Automatons are likewise hindered from entering a limited zone, for example, military offices that are leading experimentation and dynamic military preparing inside their camps. These developing limitations prompt ramble clients to consider the principles and guidelines of automaton utilization to a specific territory with the goal that they won't be exposed to either moral or legitimate infringement. Client violators are in danger for lawful worry that could command them to pay for money-related remuneration or detainment for a few days whenever found damaging laws.

II. LITERATURE SURVEY

1) Plotter Kardasz et al and Jacek Doskocz [1] studied drones and the possibilities of their using, further they discussed the construction of drones and their most important elements such as engine, frame, propellers, communication, and control system, etc. battery-

powered drones which was a major drawback as it exhausted around 15 minutes of flight so they considered using lithium-polymer batteries for powering the drone. Further, they compared civil drones and military drones on selective examples. Civil drones differ from military drones in size and drive. Civil drones are powered by batteries and electric motors whereas military drones are bigger and may be powered by internal combustion engines. They also studied the major risk involved in drones is fall of drones from a great height, Discharge of batteries, hitting obstacles such as trees and other objects. Kumar and Michael [2] studied trajectory planning, modeling of a quadcopter platform. They also faced several problems in flight formation which provided an opportunity for facing these challenges.[3] Priyanka S. Wadkar and shruti S etals studied Arduino-based drones controlled by android applications. Etals focused on Android mobile phones, GPS, GSM, SMS log, Arduino, and RFD technology their study focuses on delivery system drones controlled by the mobile application. Their study binds web applications and android mobiles. Android is an open-source Linux-based working framework structured fundamentally for brilliant telephones and tablets Arduino is an advancement condition for composing Arduino programming. It is an open-source stage utilized for creating intuitive items. [4] etal Vital Varshney and etal Milvin Wilson studied PID-based stabilization of gesture-controlled drones using HIL simulation to study and understand the flight and balancing of a quadcopter drone. HIL simulation using NI ELVIS 2+ was undertaken. Etals purpose was to make an impact and collision avoidance drone prototype and tested in a controlled parameter environment. To achieve gesture control drone gyroscope and accelerometer are used in controllers and drones. Balancing, Collision avoidance, PID, and gesture control are the key features. Jessica R. Cauchard etal [5] studied the exploration into natural human drone interaction. Results show an effective agreement among people for many interaction techniques as when gesturing for the drone to stop. The recent development in aerial robotics has been studied by etal [6] Chun FUI Liew and Danielle DeLatte. Their research involved key features such as a micro-aerial vehicle, aerial robotics, flying drones, vertical take-off, and landing aircraft. They summarize the background, latest developments, and trends in UAV research along with a deep study on the definition, categories, and types of UAV.

2) Etals [7] Paul Pounds and Robert Mahony studied and researched on Modelling and Control of a Quad-Rotor Robot. They have built up the X-4 Flyer, a quad-rotor robot utilizing an exclusively constructed frame and flying with off-the-rack engines also, batteries, to be a profoundly solid exploratory stage. The vehicle utilizes tuned plant elements with a locally available implanted demeanor controller to settle flight. A straight SISO controller was intended to manage the flyer mentality. Etals [8] Mohamed Alsheakhali and Ahmed Shaik studied Hand Gesture Recognition System. Another method is proposed which starts by distinguishing the hand and deciding its jog, following the hand's direction

and breaking down the varieties in the hand areas, lastly perceiving the motion. The proposed method beats the foundation's multifaceted nature and good ways from the camera which is up to 2.5 meters. Test results show that the proposed procedure can perceive 12 motions with a rate above 94%. Etal [9] Yi-Jen Mon researched on The Gyroscope Sensor Test by Using Arduino Platform. The spinner can get precise information of movements for space of three measurements, for example, tomahawks of x, y, and z. Its applications are secured generally, for example, in a cell phone, shopper gadgets, and so on because of the powerful sense capacities of course and movement. In this paper, it is utilized to get information from movement and this information appears in window and LCD screen. A gesture-controlled robot is controlled by using the hand in place of any other method like buttons or joystick. Here one only needs to move a hand to control the robot. A transmitting device is used in your hand which contains the BT module and accelerometer. This will transmit a command to the robot so that it can do the required task like moving forward, reverse, turning left, turning right, and stop. All these tasks will be performed by using a hand gesture.

During this opposition, numerous organizations will be in participation and the most persuading part of this task is the opportunity to win and advance the University.

III. PROBLEM STATEMENT AND OBJECTIVES

A. Problem Statement

Quadcopters are multirotor helicopters, which contrast from the traditional helicopters since it is lifted and moved by four rotors. They utilize a free variety of the speed of every rotor to accomplish command over their flight. Albeit simpler to control than their helicopter partners, quadcopters have a notoriety of being difficult to control and regularly required valuable time to be dedicated by the pilot to deal with its development.

Conventional transmitters/controllers utilize a huge number of switches, switches, and joysticks to control a quadcopter. Albeit effective for exactness flight, these controllers have a famously hard expectation to absorb information. It regularly takes a pilot over 70 hours of preparing to have the option to control the quadcopter appropriately. As a general rule, individuals end up taking courses to have the option to fly a straightforward automaton.

The reason for this undertaking is to discover an answer to this issue. This can be accomplished by building a transmitter and beneficiary, not the same as customary ones, which can be utilized to effectively control an automaton. The glove which will fill in as a controller would have a gyrator worked in which would be used to change over signals given by the client to control the quadcopter. The client would have the option to utilize little developments of his hand to control the automaton, consequently bypassing the lofty expectation to learn and adapt to conventional controllers.

B. Motivation

The motivation for the proposed project emerged from an assortment of reasons. The principal major's explanation behind picking such a task is the capacity the venture needs

to include each colleague. It is accepted that planning the stage and target acknowledgment program will satisfactorily satisfy the necessity. The most significant perspective is to ensure every one of the four colleagues uses the four long stretches of undergrad concentrate in mechanical designing. Framework coordination will be the key focal point of the undertaking as the main planned parts will be the structure of the framework. This project will allow involving different streams such as mechanical, electronics, and computer science.

One of the main motivations regarding this project is its future scope this projects gesture-controlled provide an opportunity to reduce the time to practice control the drone over conventional remote controls. The emerging benefits such as fast delivery of good door to door, Military purposes, Quick services to public need such as medical, food, water in times of epidemics, floods, etc.

IV. DESIGN AND DEVELOPMENT OF DRONE

Each social event entering the limitation is allowed to pick an aeronautical stage that will play out the predefined assignments. The social event experienced careful research and evaluation of three fundamental stages; helicopter, fixed-wing plane, and multi-rotor copter. Among these three stages are essential incredible conditions and loads that must be considered before picking the ideal stage. Helicopters and multi-rotor copters have indistinguishable great conditions as they are permitted to take off and land fundamentally any place. The two stages can skim in one place and can move in any pivot from a point with extraordinary adaptability. Each style can pass on a little payload if central in any case travel consistently, with the multi-rotor venturing somewhat quicker. Planes, then again, can travel giant allotments at a snappier rate. Planes can be sorted out continuously clear and fix costs are on a very basic level, not a multi-rotor stage.



Fig. 4.1: Design of A Model Plane

While the entirety of the three stages shows colossal upside, every ha it's a huge number of loads. Multirotor stages require thorough programming close by the inauspicious change of the engines. The heaviness of multi-rotor stages must be scattered impartially to maintain a strategic distance from over repaying an engine. A vital debacle for the multi-rotor stage is in-flight issues; if an 18 engine chooses to give out, the ethereal vehicle will rapidly go to a fall. Planes the proportional the multi-rotor stages must have the weight passed on unbiasedly. They, also, have the obstruction at flight and appearing as they require a lot of room to play out the two assignments. When in doubt, the plane requires a lot of room to fly in to stay away from any disasters. With everything taken into account, the helicopter has the most mind-boggling course of action among the three stages. This

intricacy is generally arranged to bafflement if not appropriately sorted out. A helicopter requires more upkeep than the other two stages.



Fig. 4.2: Design of a Quadcopter

A. Proposed Designs

A motion-controlled robot is constrained by utilizing a hand instead of some other technique like catches or joystick. Here one just needs to move the hand to control the robot. A transmitting gadget is utilized in your grasp which contains a BT module and accelerometer. This will transmit the order to the robot so it can do the necessary assignment like pushing ahead, switch, turning left, turning right, and stop. Every one of these undertakings will be performed by utilizing a hand signal.

Here the most significant segment is an accelerometer. An accelerometer is a 3-pivot speeding up estimation gadget with $+3/ - 3$ g go. The yield of this gadget is Analog in nature and relative to the speeding up. This gadget quantifies the static speeding up of gravity when we tilt it. Also, gives an outcome in the type of movement or vibration.

The signal-controlled robot moves as indicated by hand development as we place the transmitter in our grasp.

When we tilt deliver front side, the robot starts to pushing ahead and keeps pushing ahead until the next order is given.

- When we tilt-turn on the reverse side, the robot changes its state and begins moving in reverse heading until another order is given.
- When we tilt it on the left side Robot gets to turn left till the next order.
- When we tilt submit right side robot went to the right.
- And for halting robot we keep turn in the stable.

B. Circuit Diagram

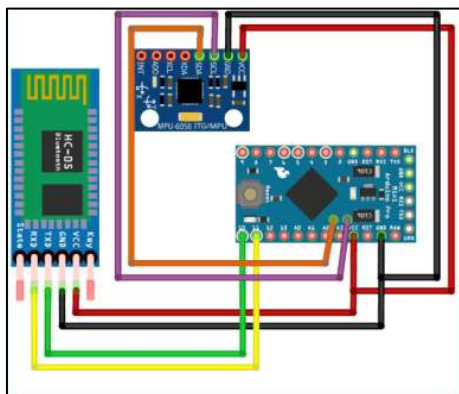

Fig. 4.3: 2-D Model of Circuit

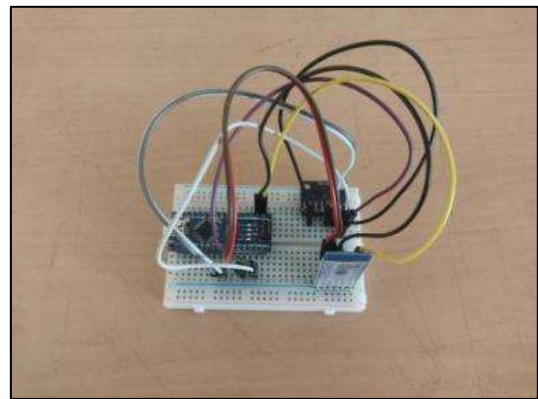

Fig. 4.4: 3-D Model of Circuit

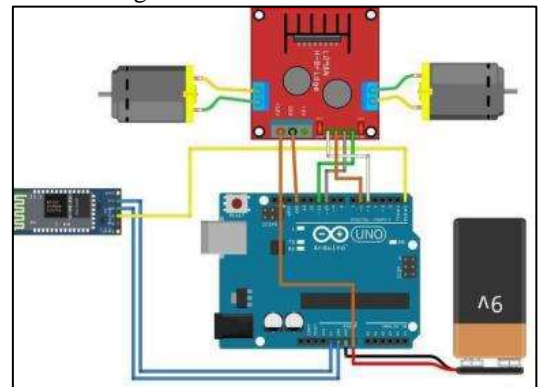

Fig. 4.5: Complete Circuit Design

Gesture Controlled Robot is divided into two sections:

- Transmitter Part
- Receiver part

In the transmitter part, an accelerometer and a BT module unit are used. As we have already discussed that accelerometer gives an analog output so here, we need to convert this analog data into digital. For this purpose, we have used 4 channel comparator circuit in place of any ADC. By setting reference voltage we get a digital signal and then apply this signal to encode data or converting it into serial form and then send this data by using BT Module to the receiving module.

At the receiver end, we have used another BT module to receive the data. This decoder IC converts received serial data to parallel and then read by using Arduino. According to the received data, we drive the robot by using two DC motors in forward, reverse, left, right, and stop directions.

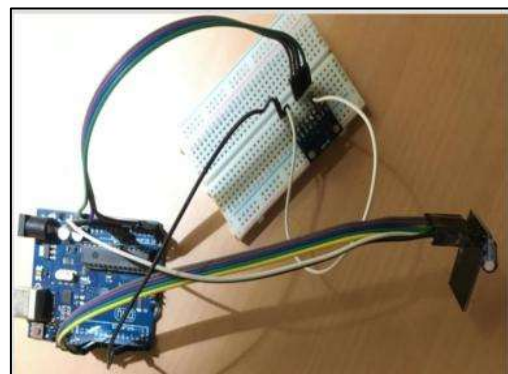

Fig. 4.6: 3-D Model of Transmitter

The same gyroscopic glove in the prototype project will be used to control the drone. The BT module is swapped

out for a 2.4 GHz Tran receiver for better range, lower latency, and higher bandwidth. The glove sends out a PPM signal to the receiver connected to the drone. The signal consists of values derived from the MPU6050 Gyroscope, which is then converted to a type recognized by the drone, which in this case being the PPM Signal.

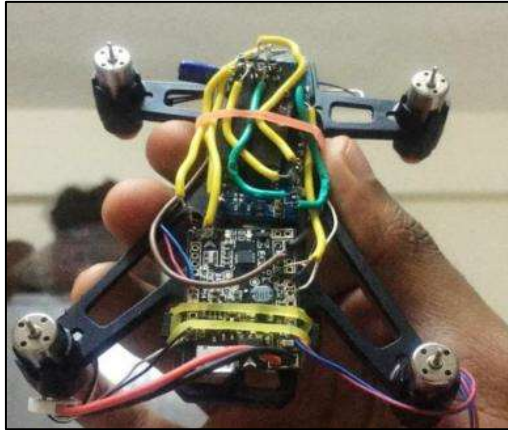

Fig. 4.7: Frame of The Drone

The Drone is fitted with a flight controller. A Drone Flight Controller, or FC, is the heart of a quadcopter and controls most onboard electrical components with the assistance of an Arduino-like microprocessor and an array of sensors. The FC is outfitted with a gyroscope and an accelerometer to calculate its angular velocity and speed and make the optimum calculations required to keep the drone flying. The FC is mounted on the drone and is connected to 4 equally spaced out coreless DC motors responsible for the flight as shown in the Figure.

The Drone is also outfitted with the same 2.4 GHz receiver that receives input from our gyroscopic glove and sends it to the flight controller, which uses that data for its flight. According to the tilt and the acceleration of the glove, the Trans receiver sends appropriate data to the drone for it to change its attitude or tilt and move around.

C. Equipment Used

a) Arduino Nano.

Arduino Nano is a somewhat, great, versatile, and breadboard neighborly Microcontroller board, made by Arduino.cc in Italy, taking into account ATmega328p (Arduino Nano V3.x)/Atmega168 (Arduino Nano V3.x). It goes with the same convenience as in Arduino UNO yet very in a little size. It goes with a working voltage of 5V, regardless, the data voltage can change from 7 to 12V. Arduino Nano Pinout contains 14 mechanized pins, 8 straightforward Pins, 2 Reset Pins, and 6 Power Pins. All of these Digital and Analog Pins are given out with different limits yet their essential limit is to be planned as data or yield. They are gone about as information pins when they are interfaced with sensors, yet if you are driving some pile, then use them as yield. Limits like pin Mode () and digital Write () are used to control the errands of cutting-edge pins while analog Read () is used to control basic pins. The straightforward pins go with a flat-out objective of 10bits which measures the motivating force from zero to 5V. Arduino Nano goes with a valuable stone oscillator of repeat 16 MHz It is used to convey a clock of careful repeat using consistent voltage. There is one constraint using Arduino Nano for instance it doesn't go with

a DC power jack, which suggests you cannot deftly externally power source through a battery. This board doesn't use standard USB for a relationship with a PC, rather, it goes with Mini USB support. Minimal size and breadboard neighborly nature choose this contraption an ideal choice for most of the applications where the size of the electronic fragments is of extraordinary concern. Streak memory is 16KB or 32KB that all depends upon the Atmega board i.e. Atmega168 goes with 16KB of blast memory while Atmega328 goes with a flash memory of 32KB. Streak memory is used for taking care of code. The 2KB of memory out of complete flash memory is used for a bootloader.



Fig. 4.8: Arduino Nano

b) Communication Module

The nRF24L01 is a remote handset module, which means every module can both send just as get information. They work in the recurrence of 2.4GHz, which falls under the ISM band, and subsequently, it is lawful to use in practically all nations for building applications. The modules when worked proficiently can cover a separation of 100 meters (200 feet) which settles on it an extraordinary decision for all remote-controlled ventures.

The module works at 3.3V thus can be handily utilized with 3.2V frameworks or 5V frameworks. Every module has a location scope of 125 and every module can speak with 6 different modules subsequently it is conceivable to have various remote units speaking with one another in a specific zone. Thus, work systems or different sorts of systems are conceivable utilizing this module.

– How to use the module

The NRF24L01 module works with the help of SPI communications. These modules can either be used with a 3.3V microcontroller or a 5V microcontroller but they should have an SPI port. The circuit diagram shows how the module should be interfaced with a microcontroller.

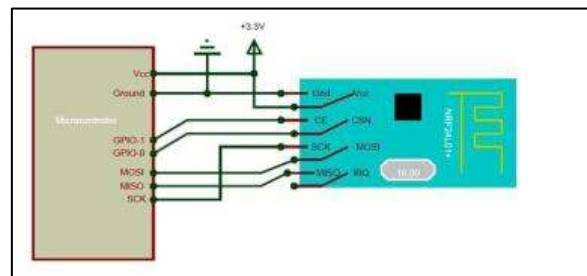

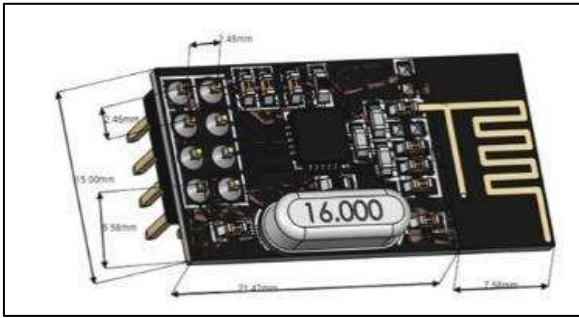

Fig. 4.9: Communication Module

c) GY-521 gyroscope

The GY-521 module is a breakout board for the MPU-6050 MEMS (Microelectromechanical systems) that features a 3-axis gyroscope, a 3-axis accelerometer, a digital motion processor (DMP), and a temperature sensor. The digital motion processor can be used to process complex algorithms directly on the board. Usually, the DMP processes algorithms that turn the raw values from the sensors into stable position data.

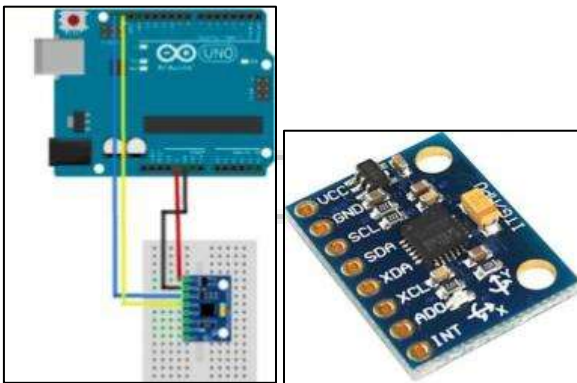

Fig. 4.10: Gyroscope Batteries. (Li-Po/9V).

d)



Fig. 4.11: Battery

A lithium polymer battery, or even more successfully lithium-molecule polymer battery, is a battery-fueled battery of lithium-molecule advancement using a polymer electrolyte as opposed to a liquid electrolyte. High conductivity semisolid (gel) polymers structure this electrolyte. Lithium-polymer batteries are lighter and more adaptable than different sorts of lithium-particle batteries due to their delicate shells, permitting them to be utilized in portable and other electronic gadgets, just as in remote control vehicles.

e) Coreless DC Motors

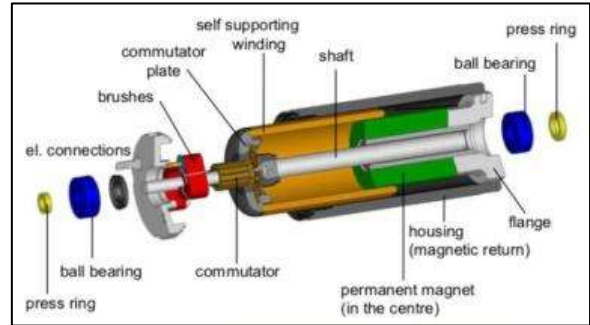

Fig. 4.12: Coreless Dc Motor

A coreless DC motor disposes of the iron community in the rotor. Or maybe, the rotor windings are curved in an inclined, or honeycomb configuration to shape a self-supporting void chamber. The stator magnet sits inside the coreless rotor. The brushes used in coreless DC motors can be made of significant metal or graphite. The improvement of coreless DC motors gives a couple of focal points over standard, iron-focus DC motors. The coreless structure furthermore reduces winding inductance, so beginning between the brushes and commutator is diminished, growing motor life and decreasing electromagnetic impedance.

To your control and may even experience issues on take-off. For instance, on the off chance, we had a quadcopter that weighs 1kg, the aggregate thrust created by the motors at 100% throttle should be no less than 2kg or 500g for each motor (which is multiplied by 4 for a quadcopter). This will give you better control, as well as the space for including additional payload later on (like heavier cameras, or possibly additional batteries to extend flight time).

f) Flight controller

The qualification with multi-rotors, regardless of whether favorable, is that no human is fit for controlling the rotational paces of at least three engines all the while with enough exactness to adjust an art noticeable all around. This is the place flight controllers come into play. A flight controller (FC) is a little circuit-leading body of fluctuating multifaceted nature. It can coordinate the RPM of each engine in light of info. An order from the pilot for the multi-rotor to push ahead is taken care of into the flight controller, which decides how to control the engines accordingly. The larger part of flight controllers additionally utilizes sensors to enhance their estimations. These range from basic gyrotors for direction to gauges for consequently holding elevations. GPS can likewise be utilized for auto-direct or safeguarding purposes. More on that in a matter of seconds.

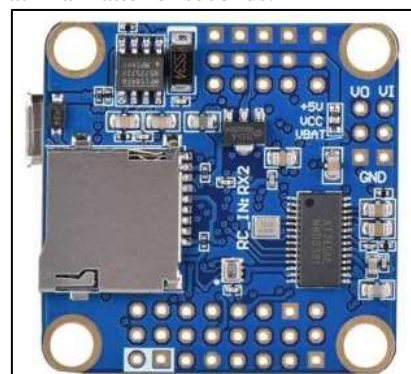

Fig. 4.13: Flight Controller

g) Multi-Rotor Mechanics

Because of the way that our structure changed through the course of the proposition stages, further research was directed to all the more likely comprehend the mechanics of multi-rotor frameworks. A quad-rotor helicopter is a helicopter that has four similarly divided rotors, orchestrated at the edges of a square edge. The requirement for a swashplate system utilized on helicopters is disposed of because of the four free rotors. Electronic help is expected to control the quadcopter and that being said it is as yet a test. The stage has six degrees of opportunity (three translational and three rotational) with just four autonomous data sources. To accomplish six degrees of opportunity, rotational and translational movements are coupled. The subsequent elements are nonlinear, particularly in the wake of representing the streamlined impacts. At last, rotor vehicles have almost no grinding to forestall their movement, so they should give their damping to quit moving and stay stable. These elements make fascinating control issues. Before any further theory, the classification forbearing of movement will be similar to some other airplane. Alluding to Figure, the direction of the quadcopter is controlled by the move, pitch, and yaw.

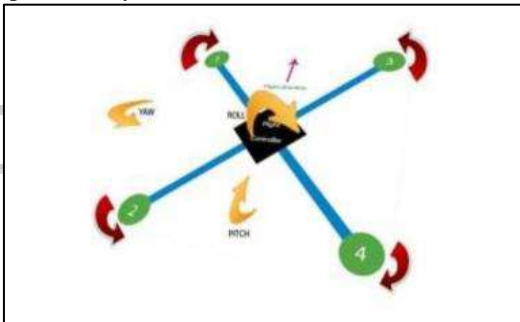

Fig. 4.14: 2-D Model of Multirotor

Every rotor produces both powers in the vertical course officially known as push and torque about its focal point of revolution. A drag power is likewise made inverse to the vehicle's heading of movement. At the point when all rotors are turning at the equivalent precise speed, there is a net streamlined torque about the yaw pivot and it is zero. To achieve this, we start by calling the primary rotor R1, and the rotor straightforwardly opposite it R3. The other two rotors are called R2 and R4. Rotors R1 and R3 must turn in the equivalent rakish speed. This makes a torque that must be balanced. Rotors R2 and R4 should likewise turn a similar way however inverse precise speed of R1 and R3. The Figure shows how every rotor is designed to turn to accomplish a decent stage.

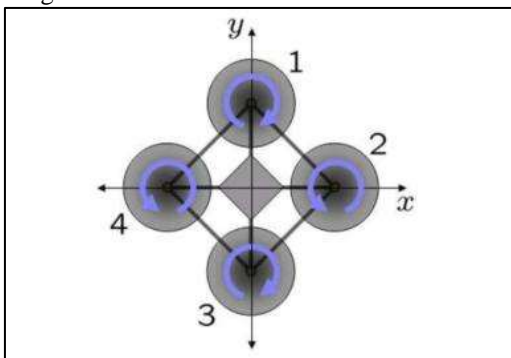

Fig. 4.15: Axis Orientation of the Motors

- Case 1: Loitering
Rotor stages have the one-of-a-kind capacities to linger (drift) in a territory. Contingent upon the application, it presents favorable circumstances and detriments. To accomplish this kind of position, the push power must be equivalent to the heaviness of the stage. Note that four sources make a push in this manner the complete push made must be equivalent to the heaviness of the stage. Standing around is powerless against whirlwind and any factor power against the stage.
- Case 2: Take-off & Landing
Rotor stages needn't bother with a departure strip to start-up. With the necessary space, rotor stages have the preferred position to take off from any ideal area. The push power must be more noteworthy than the heaviness of the stage to move in the vertical course. The present innovation offers light engines with extraordinary push capacities. Accordingly, an administrator must be aware of the push-to-weight proportion as quadcopters are intended to be light in weight to streamline flight time. A recommended push to weight proportion for take-off is 1.05 to permit sufficient reaction time and ideal control. The equivalent can be said for arriving as you would prefer not to come smashing down at a high speed. Push to weight proportion again is significant as you need to slide gradually to the ground before slicing off capacity to the engines. To drop, it is prescribed to begin at a high height if something turns out badly and to screen your push to weight proportion at 0.95.
- Case 3: Roll, Pitch, Yaw
Move, pitch, and yaw direct the mobility of the quadcopter. Every one of the three requires control of the torques incited by the rotors. Roll and pitch are a similar sort of movement exactly in various directions. Move controls development from left to right, while pitch controls forward and in reverse. A quadrotor alters its pitch or moves by applying more push to one rotor and less push to its oppositely inverse rotor. It is likewise conceivable to change roll and pitch by applying more push to two rotors that are close to one another while the other two offer less push. One can't just simply add push to a couple of rotors as that will make a lop-sidedness of push and roll or pitch the stage, yet also, drive it upward. Accordingly, it is 24 basics to decrease push in different rotors. To modify yaw, rotors turning a similar way must expand push yield or the other way around.

V. COST ANALYSIS

The table shows a rough estimation of the parts used to develop and set a working model. Desires for the model were for the most part to accomplish flight self-rulingly and to construct a gyroscopically controlled glove while utilizing a human motion as a kind of perspective. Practically 90% of the parts extend to the last plan with the significant contrast being the expense of the structure. What is neglected to be depicted is the surprising expense because of part disappointment, and harm from crashes. The real expense surpasses what is list beneath since the undertaking experienced an arrangement of investigating occasions. Aside from segment costs, material and assembling cost can

be added however will, in general, be irrelevant in the examination. The model was intended to be modestly supplanted assuming any segments were to break or come up short during tests.

The flight controller and batteries were expensive which carrier around 40% of the total price of 1600 rupees each and along with that coreless motors which were used four in this drone that cost around 1200 rupees. The total expenses are listed below which is around 6890 rupees. But in reality, the cost differs, the cost mentioned is only of parts of drones apart from that there are other expenses such as traveling, food, broken parts, miscellaneous stationaries, etc.

SL.NO	COMPONENTS	PRICE	QUANTITY	AMOUNT (IN RS)
1	Quadcopter Frame	500	1	500
2	Coreless DC Motor	300	4	1200
3	Flight Controller	1600	1	1600
4	1S Li-Po Battery	800	2	1600
5	Propeller (2CW/2CCW)	170	2	340
6	Li-Po Battery Charger	300	1	300
7	2.4 GHz RC Transmitter	250	2	500
8	Arduino Nano	350	1	350
9	Gyroscopic Sensor	250	2	500
		TOTAL		6890

VI. CONCLUSION

Traditional transmitters/controllers use a multitude of switches, levers, and joysticks to control a quadcopter. The basic problem with the traditional transmitters/controllers use a multitude of switches, levers, and joysticks to control a drone. Although efficient for precision flight, these controllers have a notoriously hard learning curve. It regularly takes a pilot over 70 hours of preparing to have the option to control the quadcopter appropriately. As a general rule, individuals end up taking courses to have the option to fly a straightforward automaton.

This project aims to undercut the time taken by an individual to learn to pilot a quadcopter, by developing an alternate and easier mode of control. The objective can be achieved by building a pair of transmitter and receiver, which can be used to easily control a quadcopter. In this project, we present our implementation of using a motion controller to control the drone via simple human gestures. The glove will serve as a controller. The controller would then send the signal to a paired receiver connected to the quadcopter. The user would be able to use small movements of his hand to easily control the quadcopter. Thus, reducing the training time to learn the controls of a drone.

Due to the reduction in the learning curve, drones can be used easily and by everyone, thus increasing their

applications. Drones are being used by the world's military forces. Aerial or orthographic surveillance of land to identify and control potential crop threats, such as pests or fungus infestations, will be possible. The drone can be used to survey and audit various aspects of mining operations, including berm erosion, road analysis. The drone can be used to survey build sites, monitor operations and progress, Power lines, turbines, towers, and dams can be inspected, it can be used for traffic surveillance and accident assessment.

REFERENCES

- [1] Ploter Kardasz et al, Jacek Daskocz, "Drones and Possibilities of Their Using", Journal of Civil and Environmental Engineering. Volume 6; 2016; 3
- [2] Harish Mahatma Putra, R. Dimas Pristovani, Muhamad Rausyan Fikri, "Propulsion Selection Method Using Motor Thrust Table for Optimum Flight in Multirotor Aircraft", AIP Conference Proceedings, 22 April 2020
- [3] Priyanka S.Wadkar, Shruti S Wagh, "Arduino Based Drone Delivery System controlled by Android Application", International Journal Of Advanced Engineering & Innovative Technology (IJAIEIT), Volume 3, 2016
- [4] Vital Varshney, Milvin Wilson, "PID Based Stabilization of Gesture Controlled Drones Using HIL Simulation", International Journal of Engineering and Advanced Technology (IJEAT), Volume-3 Issue-6, August 2014
- [5] Jessica R. Cauchard, "An Exploration into Natural Human-Drone Interaction", UbiComp '15: Proceedings of the 2015 ACM International Joint Conference on Pervasive and Ubiquitous Computing, September 2015.
- [6] Francesco Nex, Fabio Remondino. "Latest Developments, Methodologies, and Applications Based on UAV Platforms", Molecular Diversity Preservation International and Multidisciplinary Digital Publishing Institute, 14 March 2019
- [7] Paul Pounds, Robert Mahony 2006, "Modelling and Control of a Quad-Rotor Robot". *Proceedings of the 2006 Australasian Conference on Robotics and Automation*. The Australian Robotics and Automation Association Inc. December 2006
- [8] Mohamed Alsheakhali, Ahmed Shaik, "Hand Gesture Recognition System", Computer Engineering Department, The Islamic University of Gaza, 2011
- [9] Yi-Jen Mon, "The Gyroscope Sensor Test by Using Arduino Platform" INTERNATIONAL JOURNAL OF SCIENTIFIC & TECHNOLOGY RESEARCH VOLUME 4, ISSUE 06, JUNE 2015
- [10] Evan Baldwin Carr, "Unmanned Aerial Vehicles: Examining the Safety, Security, Privacy and Regulatory", National Centre for Policy Analysis (NCPA), September 23 2014.
- [11] Gilles Albeaino, "A SYSTEMATIC REVIEW OF UNMANNED AERIAL VEHICLE APPLICATION AREAS AND TECHNOLOGIES IN THE AEC DOMAIN". Journal of Information Technology in Construction (ITcon), (2019)
- [12] Angshuman Bhattacharjee, Arghya Hazra, Suvam Kumar Aar, "Quad Copter Control Using Arduino

- Microcontroller”. Project report submitted to RCC Institute of Information Technology, Kolkata. May 2018
- [13] Ravi Kangir, Dr. A. D. Desai “Design and Analysis of Non-Conventional Co-Axial Rotor Blade for Multipurpose Drone”, International Journal of Science, Engineering and Technology Research (IJSETR), Volume 4, Issue 10, October 2015.
- [14] Gordon Ononiwu, Arinze Okoye and James Onojo “Design and Implementation of a Real Time Wireless Quadcopter for Rescue Operations”, American Journal of Engineering Research (AJER), Volume-5, Issue-9, 2016

