

Experimental Analysis of SI Engine by HHO Gas Method

Mr.S. D. Marjapure¹ Mr. S.S. Patil²

^{1,2}Assistant Professor

^{1,2}Department of Mechanical Engineering

^{1,2}D. Y. Patil COE, Akurdi (Savitribai Phule Pune University), India

Abstract— The objective of this work was to construct a simple innovative HHO gas generation system and evaluate the effect of combustion with HHO addition, as an engine performance improver, into gasoline fuel on engine performance and emissions. HHO cell was designed, fabricated and optimized for maximum HHO gas productivity per input power. This project consists of a small electrolysis fuel cell, non-return valves, 12V Battery, Two stroke SI engine and carbon filter. The electrolysis fuel cell is used to generate HHO gas (electrolysis process) by using 12-volt battery. The carbon filter is used to absorb the water and dirt particles from HHO gas. And then these gases pass to the engine after the carburettor and control the gasoline charge. The results showed that the HHO gas maximum productivity of the cell was 18 L/h when using 2 neutrals plates with 1 mm distance and 6 g/L of KOH. The results also showed 10% increment in the gasoline engine thermal efficiency, 34% reduction in fuel consumption, 18% reduction in CO, 14% reduction in HC and 15% reduction in NOx.

Key words: Carbon Filter, Electrolysis Fuel Cell, HHO Gas

I. INTRODUCTION

A trending global concern, toward lowering fuel consumption and emissions of internal combustion engines, is motivating researchers to seek alternative solutions that would not require a dramatic modification in engines design. Among such solutions is using H₂ as an alternative fuel to enhance engine efficiency and produce less pollution. Now a day's hopes have again been raised about production and development in "hydrogen economy" sector because most of them agreed that hydrogen is best alternative fuel to replace the existing fossil fuels as hydrogen is having the clean burning characteristics. For an engine running only with hydrogen the exhaust gases doesn't contains carbon oxides, hydrocarbons, particles and lead compounds excluding the unburned hydrocarbons or the carbon oxides provided by oil burning inside the combustion chamber. The hydrogen gas is acting as a light gaseous fuel. It is having high heating value on mass basis, wide flammability that gives wide mixture range in air which permits extremely lean or rich mixtures to support combustion. It requires lower amount of energy to start ignition process which results in extremely high-speed flames. Its energy released by combustion per unit mass of chemically correct mixture remains high. The combustion properties of hydrogen have much influence on its performance as an engine fuel. There are mainly two different ways available to introduce hydrogen in combustion chamber for burning process.

II. OBJECTIVES

- 1) To increase the efficiency of gasoline engine with the addition of HHO gas.

- 2) To decrease fuel consumption and improve engine thermal efficiency increases.
- 3) To evaluate the effect of combustion with HHO addition, as an engine performance improver, into gasoline fuel on engine performance and emissions
- 4) To control the exhaust gas emissions.

III. CONSTRUCTION OF MODEL

This project consists of a small electrolysis fuel cell, Non return valves, safety valve, 12V Battery, Two stroke SI engine and carbon filter.

The electrolysis fuel cell is used to generate HHO gas (electrolysis process) by using 12-volt battery. The carbon filter is used to absorb the water and dirt particles from HHO gas. And then these gases pass to the engine after the carburettor and control the gasoline charge.

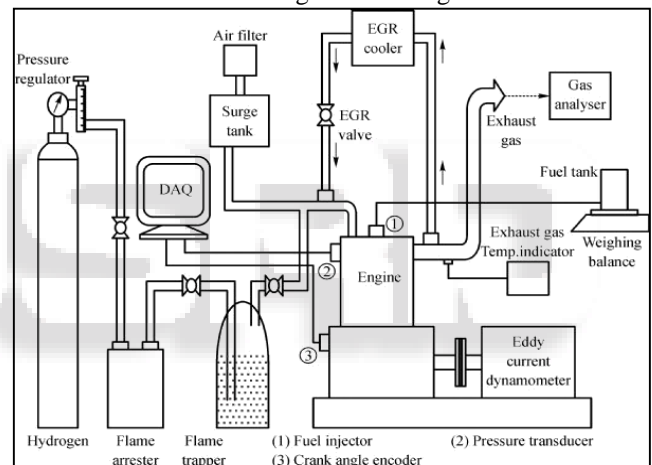

Fig. 1: Line Diagram of Gasoline-Hydrogen Operated 2-Stroke SI Engine

Figure 1 shows the line diagram of our project and the dynamo is used to charge the battery and diodes are used to convert the AC supply in DC.

IV. WORKING

Hydrogen fuel cell is used to generate the HHO gas. It consists of a separation tank in which two electrodes made up of stainless steel of battery one is anode and other is cathode are dipped in water and then 12-volt supply is given to the terminal and electrolysis process gets started which helps to generate the HHO gas. The details of the experimental setup are shown in figure 2.



Fig. 2: Experimental Setup

Then this gas is passing through the non-return valve and then carbon filter. In carbon filter moisture and dirt particles will absorb and then supply to the inlet of engine after the carburettor. This supply of HHO gas at inlet of engine helps to improve combustion process and also control the exhaust gas emission.

V. RESULTS & DISCUSSION

The results are shown in table 1 below.

Sr No.	Substance	Quantity of fuel (ml)	Speed (rpm)	Time (sec)
1	Gasoline	10	300	150
2	Gasoline + HHO Gas	10	300	200

Table 1: Fuel Quantity Speed & Duration

- 1) First, we take result on 2stroke SI engine for 10ml gasoline at 300 RPM, its run for 150 seconds.
- 2) Than we take result for 10ml gasoline with HHO gas addition at 300 RPM then its run for 200 seconds.

VI. ADVANTAGES

- 1) Increase the efficiency of IS engine.
- 2) Consumption of fuel is less.
- 3) The results also showed 10% increment in the gasoline engine thermal efficiency, 34% reduction in fuel consumption, 18% reduction in CO, 14% reduction in HC and 15% reduction in NO_x.
- 4) If hydrogen is used as supplementary fuel in SI engine then it results in improved engine performance.

VII. CONCLUSION

The efficiency of the engine is increase by using combine mixture of Hydrogen and oxygen gas insert into the inlet of SI engine. And also control the exhaust gasses.

REFERENCES

- [1] B.R. Prasath, E. Leelakrishnan, N. Lokesh, H. Suriyan, E. G. Prakash, O. M. Ahmed, 'Hydrogen Operated Internal Combustion Engines – A New Generation Fuel', ISSN 2250-2459, Volume 2, Issue 4, pp 52-57, April 2012.

- [2] Yuksel and M.A. Ceviz, 'Thermal Balance of a Four Stroke SI Engine Operating on Hydrogen as a Supplementary Fuel', Journal of Energy, Vol 28, Issue 11, pp 1069–1080, 15 Sept 2003.
- [3] N. Negurescu, C. Pana, M. G. Popa and A. Cernat, 'Performance comparison between hydrogen and gasoline fuelled spark ignition engine', Thermal Science, Volume 15, No. 4, pp 1155-1164, 2011.
- [4] R. Sierens and S. Verhelst, 'Hydrogen Fuelled Internal Combustion Engines. Commission of the European Union', Progression in Energy and Combustion Science, Vol 35, Issue 6, pp. 490-527., Dec 2009.