

Design & Fabrication of Cam Operated Riveting Machine

Prof. N. Jayashankar¹ Shrvanath A.² Ashik B.³ Akash Kn.⁴ Sharath K.⁵

¹Associate Professor ^{2,3,4,5}UG Student

^{1,2,3,4,5}Department of Mechanical Engineering

^{1,2,3,4,5}Vidyavardhaka College of Engineering, Mysuru, India

Abstract— In many industries various types of machines and equipment have been used for various operations such as riveting, forging, hammering, cutting etc. But different problems such as low power supply, less man power and also heavy laborious work force, safety etc. This projects relates to operation performed by this can be achieved by using electric motor power attached to the shaft and hammering action can be provided. Belt drive is provided for speed reduction and power transmission so that the suitable speed can be achieved. Also the handling is simple and maintenance of the machine is easy.

Key words: Cam Operated Riveting Machine

I. INTRODUCTION

In the field of manufacturing, utilizing hydraulic and pneumatic mechanisms makes capital cost more, which makes it easier only for large scale industries. In order to reduce the initial cost, a “trip hammer” has been made using simple cam mechanism that can aide the small scale industries and as well as making it possible to employ a semi-skilled labor. This can be a boon for small scale industries who undergoes immense manual labor and cannot afford automations either. So with a view of reducing the burdens of the trip hammer has been used which functions simply when motor rotates unlike the conventional method of raising the tool by hands involving fatigue of human workforce. Additionally health issues such as elbow strains and wrist pains that occur owing to continuous laboring in conventional methods can be eliminated to a major extent.

The cam operated riveting machine is a device which can be used for multi-purpose operations. It is mainly used for riveting. It can also be used for various purposes such as punching, forging, bending, etc. This cam operated riveting machine is very essential for doing number of such operations like crushing, hammering of work piece and cutting of metal.

II. DESIGN OF THE MACHINE

A. CAD Design

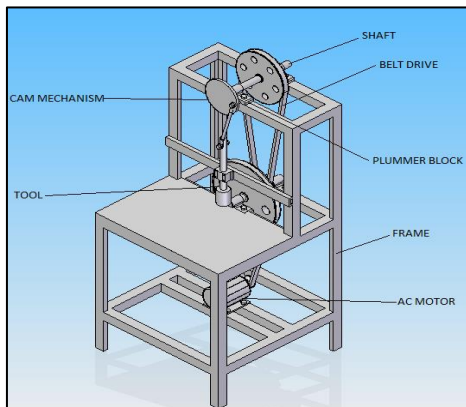

Fig. 1:

B. Parts

1) AC Motor

It is the main part which provides rotational movement for cam mechanism.

2) Belt Drive

These are used for power transmission from motor to cam mechanism and for speed reduction.

3) Frame

It is a structure that supports all other components of the machine.

4) Shaft

They act as a supporting structure for rotating elements.

5) Plummer Block

It is a pedestal which provides support for the rotating shaft with the help of compatible bearings.

6) Cam Mechanism

It is used to obtain reciprocating motion of the tool.

C. Operation

An electric motor, which is having 1440 rpm is used to rotate the eccentric mechanism by pulley V-belt arrangement. The eccentric mechanism converts rotary motion into reciprocating motion. The tool which is attached to the eccentric mechanism reciprocates. A rail mechanism is provided for proper movement of the tool. The rivets are kept on the work table below the tool. As the tool applies continuously load on the rivet, under the action of tool riveting operation takes place.

D. Calculation

1) Speed Reduction

Motor speed, N1 = 1440 rpm (constant)

Speed of middle shaft, N2 = ?

i.e $N1D1 = N2D2$

$N2 = N1D1 / D2$

$$N2 = \frac{1440 \times 2.54}{30.48}$$

Speed of middle shaft, N2 = 120 rpm

Speed of upper shaft = ?

$N2D2 = N3D3$

$N3 = N2D2 / D3$

$$N3 = \frac{120 \times 5.08}{15.24}$$

Speed of upper shaft, N3 = 40rpm

Minimum Force Required for Riveting:

Impact loading formula is given by,

$$\sigma = \frac{W}{A} \left(1 + \sqrt{\frac{1+2hEA}{WL}} \right)$$

$$240 = \frac{W}{\frac{\pi}{4} \times 14^2} \left(1 + \sqrt{\frac{1+(2 \times 155 \times 69 \times 10^3 \times \frac{\pi}{4} \times 14^2)}{W \times 15}} \right)$$

W=6.21 Newton

Force required for riveting is 6.21N

Power Requirement:

$$\text{Power} = \frac{2 \times \pi \times N \times T}{60000}$$

$$P = \frac{2 * \pi * 40 * (6.21 * 7)}{60000}$$

$$P = 0.1820 \text{ kilowatt} = P = 0.244 \text{ HP}$$

Since 0.244 HP motor is not available, selecting 0.5 HP AC motor.

$$P = 0.5 \text{ HP}$$

E. Parts specification

- Length of belt(1)=1414mm
- Length of belt(2)=1404mm
- Motor pulley dia=50mm
- Cam shaft pulley dia=230mm
- Length of shaft=250mm
- Dia of shaft=25mm

III. ADVANTAGES

- 1) Initial cost is low.
- 2) Simple construction & even a semi-skilled labour will be able to operate.
- 3) Size is compact such that if needed shall be carried from one place to another with minimal difficulties.
- 4) Maintenance cost is low.
- 5) Different operations can be performed in this machine like hammering, blanking etc.

IV. COMPARISON

Compared with other riveting machine, our machine is compact and light in weight. The rate of production is also increased in comparison with existing riveting machine.

V. CONCLUSION

In this paper from above we conclude that:

- 1) The cam operated riveting machine can reduce the cost upto 39% compared to existing machine.
- 2) The weight has been reduced upto 38% compared to existing machine.

REFERENCES

- [1] Manish Kale et al, International Journal of Emerging Technology and Advanced Engineering, A Review Paper on Development of SPM for Drilling and Riveting Machine, ISSN 2250-2459, ISO 9001:2008 Certified Journal, Volume 5, Issue 4, April 2015
- [2] Howard Terhune, Cleveland, Ohio, United States Patent office journals, Application – September 27, 1944, Serial no. 555977, Patented Oct. 28, 1947, Published no. US2429780
- [3] Harold S. Sheldon, Tekoa, Washington DC, United States Patent office journals, Application – October 15, 1947, Serial no. 779931, Patented – March 21, 1950, Published no. US2501542
- [4] N.H. Hoang, R. Porcaro, M. Langseth, A.G. Hanssen, “Self-piercing riveting connections using aluminum rivets”, International Journal of Solids and Structures, Norwegian University of Science and Technology, N-7491 Trondheim, Norway
- [5] James Kepnar, Lawrenceville, GA (US), United States Patent office journals, Application filled – March 23, 2001, Serial no. 09/815,677, Patented September. 26, 2002, Published no. US 2002/0133997 A1

- [6] J.J. Gupta Et Al, United States Patent office journals, Application – December 2, 1955, Serial no. 550718, Patented Oct. 23, 1957, Published no. US2789540
- [7] Ulrich Demuth, Erbach-Ernstbach; Winrich Habedank, Diez, both of Germany, United States Patent office journals, Application - November 20, 1996, Patented August 29, 2000, Patentno. 6109364, Published no. US006109364A