

Vehicle Tracking using GPS & GSM

Deepak Kumar Bhushan¹ Madhur Kumar² Himanshu Pant³ Smriti Singh⁴

⁴Assistant Professor

^{1,2,3,4}Department of Electrical & Electronics Engineering

^{1,2,3,4}SRM Institute of Science & Technology, Delhi NCR Campus, Modinagar, (U.P), India

Abstract— This system is a combination of various electronic device, in which we can locate the position of our vehicle by using GPS and GSM technology. Global Positioning Vehicle System (GPS) & GSM is used in Modern Vehicle Tracking System to locate the longitudinal & latitudinal position of vehicle. We can also used other technology to track the vehicle. This technology provide the real time vehicle location. We use microcontroller to control the GPS module to get geographic coordinate position of vehicle. A GPS receiver calculates its position using the signal from GPS satellite. The GPS stored the data from satellite & this data stored in the form of latitude & longitudinal position. To find the path of the vehicle we need to send a message to the GSM, which get activated by receiving our message. At this instant GPS get automatically deactivate by the help of relay & GSM provide the last received position from the GPS and send the message to a particular number which is executed in the program. After this the GSM get deactivate and GPS get activate. This is a cyclic process.

Key words: GSM (Global Service for Mobile Communication), GPS (Global Positioning System), Vehicle Tracking, Navigation

I. INTRODUCTION

This project is designed to find the exact position of the vehicle through SMS. This is a very simple & cheap method to provide real time vehicle location. This is a good method to prevent our vehicle from stolen. It can be used in vehicle used for carrying valuable goods, to keep track of the status of delivery & location of vehicle all time. This vehicle ensures vehicle security and smooth fleet management. This system provide the geographical position from the GPS satellite. This project can further enhanced by making an arrangement to stop the vehicle ignition by owner remotely sending SMS in theft situation.

II. BLOCK DIAGRAM

The hardware and software requirement of a GSM-GPS based vehicle tracking system include micro controller unit (at89c52), max232, GSM module, resistor, capacitors, voltage regulator, db9 connector, GPS, LCD display, keil compiler and language embedded. The 230V AC is a first step down to 12V AC using a step down transformer. This is then converted to DC using bridge rectifier. The AC ripple are filtered out by using a capacitor and given to the input pin of the voltage regulator 7805. At the output pin of the regulator, we get a constant 5V which is used for MC and other ICs in the processor (Block Diagram: Figure 1)

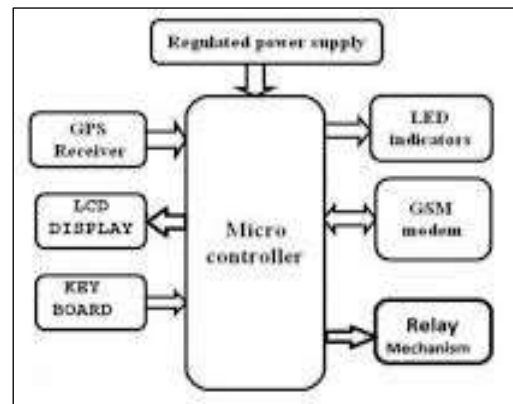

Fig. 1: Block Diagram

III. GSM OVERVIEW

Global System for Mobile Communication or GSM. It is developed by European Telecommunications Standard Institute (ETSI) to describe the protocol for second generation digital cellular networks used by mobile devices such as tablets, first deployed in Finland in December 1991, as of 2014, it has become the global standard for mobile communications – with over 90% market share, operating in over 1993 countries and territories

2G network developed as a replacement for first generation (1G) analog cellular network, and the GSM standard originally described as a digital, circuit-switched network optimized for full duplex voice telephony. This expanded over time to include data communication, first by circuit-switched transport, then by packet data transport via GPRS (GENERAL PACKET RADIO SERVICES) and EDGE (Enhanced Data Rates for GSM Evolution. Or EGPRS). The GSM standard has been an advantage to both consumers, who may benefit from the ability to roam and switch carriers without replacing phones, and also network operators, who can choose equipment from many GSM equipment vendors

IV. GPS OVERVIEW

The Global positioning system (GPS) was conceived as a ranging system from unknown positions of satellite in space to unknown positions on land, Sea, in air and space. The GPS system are extremely versatile and can be found in almost any industry sector. They can be used to map forests, help farmers harvest their fields, and navigate airplanes on the ground or in the air. GPS system are used in military application and on emergency crews to locate people in need of assistance. These days people from different profession using GPS system to make their work more safer and easier.

V. CIRCUIT DIAGRAM

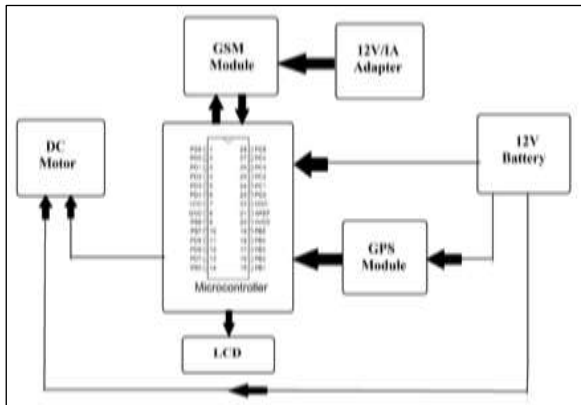

Fig. 2: Circuit Diagram

In this process we will track the location of vehicle in form of Latitude and Longitude (GPS coordinates). GPS coordinates are the value of allocation. This system is very efficient for outdoor application purpose. (Circuit Diagram: Figure 2)

Components Required:

- Aurdino
- GSM module
- GPS module
- 16×2 LCD
- Power supply
- Connecting Wire
- 10 K POT

VI. COMPARATIVE STUDY

From the above vehicle tracking system we track our vehicle at any time and from anywhere but if net access is fails then this system does not work. In this system the GPS track the location of vehicle from satellite & provide it to GSM, which provide the location on LCD in the form of latitude and longitudinal form, this system is useless without net access because the location of vehicle can only be presented by Google maps. By considering all these factors the upcoming implementation should overcome all the disadvantage and introduce many facilities which make this system easy and user friendly

VII. CONCLUSION

Vehicle tracking System nowadays a most important need for vehicle to protect it from stolen or other such type of activity and this system work as a security system for our vehicle. Many companies use GPS fleet tracking software with their service employees and this has helped them to reduce fuel costs and increase work productivity. In the future we add some sensors to this system which provide the status of the vehicle to the server, which can be useful for information processing

REFERENCE

- [1] E. D. Kaplan, Understanding GPS: Principles and Applications, Artech
- [2] R. J. Bates, GPRS: General Packet Radio Service, McGraw-Hill Professional, 1st Edition, ISBN 0071381880, November 12, 2001.

- [3] M. McDonald, H. Keller, J. Klijnhout, and V. Mauro, Intelligent Transport Systems in Europe: Opportunities for Future Research, World Scientific Publishing Company, ISBN 981270082X, 2006.
- [4] Google, Inc., Google Earth software, <http://earth.google.com/> [last accessed on Feb 1, 2008].
- [5] Google, Inc, Keyhole Markup Language Documentation Introduction, <http://code.google.com/apis/kml/documentation/> [last accessed on Feb 1, 2008]
- [6] Akintunde Musibau Ajagbe, Stephen Enyinnaya Eluwa, Edward Eric Duncan, Mohd Khairuddin Bin Ramliy, Choi Sang Long, and Mkomange Claud Wantrudis, "The Use of Global System of Mobile Communication (GSM) Among University Students in Malaysia", International Journal of Innovation, Management and Technology, vol. 2, no. 6, pp. 547-588, Malaysia, Dec. 2011.
- [7] Junaid Ali, Shaib Nasim, Taha Ali, Naveed Ahmed and syed Riaz un Nabi, "Implementation of GSM based Commercial Automobile Tracker Using PIC 18F452 and Development of Google Earth Embedded Monitoring Software". IEEE International Conference on Research and Development, UPM Serdang, Malaysia, 16-18 Nov. 2009.
- [8] Shu Wang, Jungwon Min and Byung K. Yi, "Location Based Services for Mobiles: Technologies and Standards", IEEE International Conference on Communication (ICC), Beijing, China, 2008.
- [9] Tracy M. L. Brown, Steven A. McCabe and Charles Wellford, "Global Positioning System (GPS) Technology for Community Supervision: Lessons Learned", US Department of Justice, document No. 219376, April 2007.
- [10] G. Sanders, L. Thorens, M. Reisky, O. Rulik, and S. Deylitz, "GPRS Networks". Hoboken, NJ: Wiley, 2003.
- [11] S. Hoff, M. Meyer, and A. Schieder, "A performance evaluation of Internet access via the general packet radio service of GSM", in Proc. 48th IEEE Vehicular Technol. Conf., Ottawa, vol. 3, pp. 1760-1764, 1998.
- [12] SIMCom "SIM908 Hardware Design" Version 1.06, China, 2011.
- [13] House Publishers, ISBN 0890067937, February 1996