

Analytical Performance of Motorcycle Engine using Magnetic Fuel Energizer

Harshal Borse¹ Vivek Kapase² Shivam Kubde³ Guddu Kumar Raushan⁴

^{1,2,3,4}Department of Mechanical Engineering

^{1,2,3,4}DYPCOE, Savitribai Phule Pune University, Pune, Maharashtra, India

Abstract— The aim of this research paper is to study about performance analysis on motorcycle by using magnetic fuel energizer. The motto of this experiment is to increase the fuel efficiency and to reduce exhaust emission levels. For this experiment strong permanent magnets of different strength 3000,5000,9000 Gauss are used and applied on fuel line to produce magnetic field. For this experiment exhaust gas analyzer is used to measure the emission of exhaust gases such as CO and HC. By using permanent magnet with the application of magnetic field it undergoes energy rich combustion with percentage of increased more than 4% and pollution caused by HC and CO₂ is reduced up to 5 to 20% respectively.

Key words: Gauss, Permanent magnet, Efficiency, Magnetic Intensity

I. INTRODUCTION

From last decades the use of motorcycles and cars is increasing day by day in India. Due to improper mixing of liquid and gas in Internal Combustion engine the fuel is not burning completely due to this problems are arising such as decrease in efficiency, loss of Horsepower and it also leads to produce large amount of carbon pollutants. So to overcome this problems many efforts towards improving power output and emission of Internal Combustion engines per fuel is carried out. The advantages of this is the products which developed or exhausted from IC engines becomes eco-friendly. In most of the vehicles unburned hydrogen and oxide nitrogen react and it create smog. It leads several health problems. Generally fuels present in IC engine are compound of molecules but this molecules are not realigned and not interlocked with oxygen during combustion so, for ionized and realignment of this molecule the application of magnetic field introduced by 'Fuel Energizer'. The objective of fuel energizer is to improve the turbulence and molecular excitement in fuel so that improved fuefficiency is achieved.

II. EXPERIMENTAL SETUP AND WORKIN

This section explains the basic concepts of the setup and working of fuel energizer. For the installation of fuel energizer 'Neodymium Magnet' is used which is having magnetic field intensity about 3000 Gauss

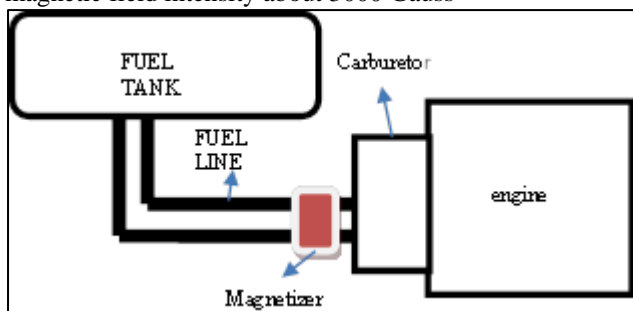

A. Schematic Diagram of Fuel Energizer

The fuel energizer can be installed just before the Carburetor of engine on fuel line. As engine started fuel started flowing through magnetic fuel line and due to this hydrocarbon change their orientation and also hydrocarbon molecules change their configuration. Due to this fuel interlocks with oxygen and it produced a more complete burn in combustion chamber this results in higher engine output, better fuel economy and reduction in HC, CO which are emitted through the exhaust.

Molecular hydrogen comes with two isomeric forms.

- 1) PARA FORM: which rotates in anti-parallel rotation in which atoms spin in opposite direction with each other. It is diamagnetic.
- 2) ORTHO FORM: Rotates in parallel rotation in which atoms spin in same direction with each other. It is paramagnetic.

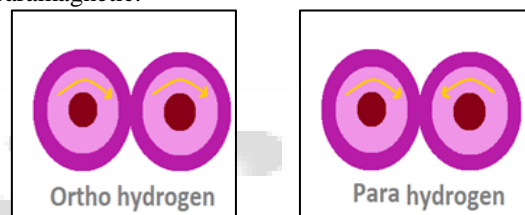

Fig. 2.2: Atomic Orientation

III. RESULTS

We have carried this experiment on motorcycle by using Neodymium Magnet based fuel energizer. We have carried this experiment with or without fuel energizer on Bajaj Pulsar 150cc.

Parameters	HC content in ppm	CO content in ppm	O ₂ content in %
Before	240	57	13.49
After	210	21	15.5
Difference in %	6.666	36	2.01

Table 1: Results obtained on Bajaj Discover before and after magnet installation.

A. Effect on HC

HC emission is reduced up to 13%

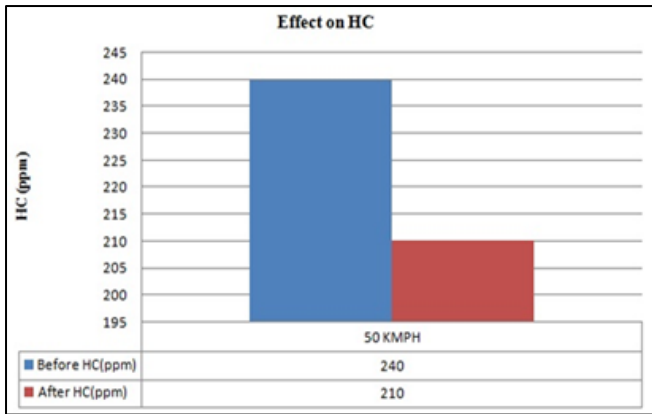

B. Effect on CO

CO emission is reduced up to 36%.

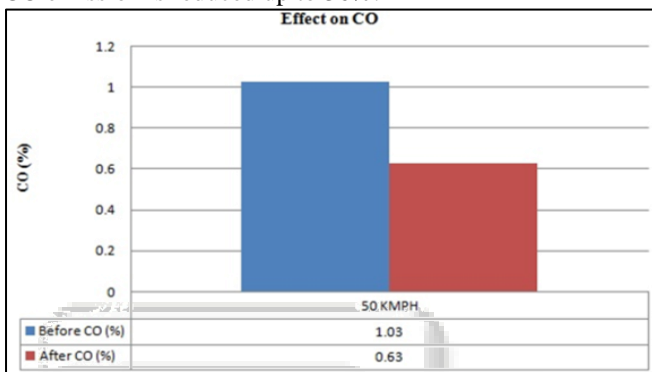

IV. BENEFITS OF THE FUEL ENERGIZER

- Upto 25% of fuel saving per mileage per litre.
- Increased acceleration and mileage.
- Reduction in exhaust smoke.
- Extend your engine life, cleans out carbon deposits.
- No tool needed for installation process.
- Reduced knocking and detonation.
- Lasts forever, simply remove from one bike and install in another bike

V. CONCLUSION

- Magnetic fuel energizer increases internal energy of fuel to cause specific changes at a molecular level which obtained easier combustion.
- The resultant fuel burn more completely, produce high engine output, better fuel economy, more power and reduces the amount of HC, CO in the exhaust.
- Magnetic fuel energizer avoids clogging problems in engine, cost saving, eco-friendly and reduce maintenance cost of engine
- By establishing correct fuel burning parameters through proper magnetic means we can assume that an internal combustion engine is getting maximum energy per litre. It increases the efficiency and helps to save the fuel up to 10%.

REFERENCES

- [1] Vivek Ugare, Nikhil Bhave, Sandeep Lutade, 2013. "Performance of spark ignition engine under the influence of magnetic field" International

- journal of research in aeronautical and mechanical engineering vol.1 Issue.3 July 2013 pgs:33-46
- [2] Farrag A.EL Fatih, 2Gad M.saber, Effect of Fuel Magnetism on Engine Performance and Emissions, Australian Journal of Basic and Applied Sciences, 4(12):6354-6358, 2010 ISSN 1991-8178.
- [3] Piyush M Patel, Gaurav P Rathod, Tushar M Patel, Performance and Emission Analysis of Single Cylinder Diesel Engine under the influence of Magnetic Fuel energizer, IOSR Journal of Mechanical and Civil Engineering (IOSR-JMCE), Volume 11, Issue Second Ver. VIII (Mar-Apr.2014)
- [4] Al Dossary, Rashid.M.A, 2009. "The Effect of Magnetic Field on Combustion and Emissions". Master's thesis, King Fahd University of Petroleum and Minerals