

# Automatic Gate Control & Monitoring the Water Reservoir using PLC

Bidya Bhusan Das<sup>1</sup> Mr. Debasis Sahu<sup>2</sup>

<sup>2</sup>Assistant Professor

<sup>1</sup>Department of Power System & Control Engineering <sup>2</sup>Department of Electrical & Electronics Engineering

<sup>1,2</sup>Centurion University of Technology & Management, 752050, Odisha, India

**Abstract**— This paper based on controlling the process variable parameters such as level and limit with real time implementation of gate controlling of DC motor using Programmable Logic Controller. In our proposed system, a programmable logic controller is used as an industrial computer playing the major role of a control devices and micro switch provide incoming signals to the control unit. The system model is provided with two levels in the one level in upper and one level in the lower outputs the ladder logic is actuated. This work uses PLC of ALLEN BRADLEY MICROLOGIX 1400 inbuilt with 20 digital inputs and provides 12 potential free outputs to control the miniaturized process depicted in the work.

**Key words:** Automatic Gate Control & Monitoring, Water Reservoir, PLC

## I. INTRODUCTION

The motivation for this project came from the countries where its economy is based on agriculture and the climatic conditions lead to lack of rains & scarcity of water. In Our India there are approximately 3200 dam are present. In Odisha, 163 dams are there all of the dams have gates. Approximately, these dams cover 1,40,000 sq.km catchment area for collecting water. There is also 2067.68 km long and complex canal network through which about 10 lakes hectares land gets water for irrigation and drinking purpose. The farmers are dependent on seasonal rain and after that bore-well water for their crops. . As we know that in our country, rainy season is of four month. And in this season sometimes rain is less or sometimes it is more than requirement. So in this condition not only farmers but all people become fully bore well or check dams dependent. The problem is that our country has so many dams which store lakhs of cusec water. But all are manually operated which cause human error. Sometimes due to heavy rain it is not possible to reach up to dam so the operator cannot send proper data or information to the head office and flood disaster may occur.

As the solution of above problem we are making this project to develop a PLC based system which detects the water level in dam and thereby control the movement of gates automatically. Automation or automatic control is the use of various control systems for operating equipment such as machinery, processes in factories, boilers and heat treating ovens, switching in telephone networks, steering and stabilization of ships, aircraft and other applications with minimal or reduced human intervention. Some processes have been completely automated. The biggest benefit of automation is that it is saves labour however; it is also used to save energy and materials and to improve quality, accuracy and precision.

## A. Why to Use PLC?

Water level in reservoir needs to be maintained effectively which is performed manually; requiring large staff and full time supervisor. This makes it very costly and inaccurate. Because of several features of PLC namely versatility, flexibility, digital nature and self-diagnostic capabilities, expandability, easy programming, implementing changes and correcting errors and pilot running has been selected to automate the dam control system in the present idea.

## II. SYSTEM DEVELOPMENT

In this system we developed the overall method in many ways. First one is that the targeted devices can be controlled by PLC (Programmable Logic Controller).

In this section the prototype that we have developed to implement the proposed system has been explained. There are various components we used to implement this system. The whole system is divided into various sections and each are explained separately.

First of all the power supply which is 12/24 volt dc from any external power supply is given to the level switches and output devices like buzzers, motors, leds etc. The signal from sensing elements is fed to the input terminal of the plc. A program is written in the plc in the form of ladder diagram and it will be processed in the CPU. Then accordingly output will be available.

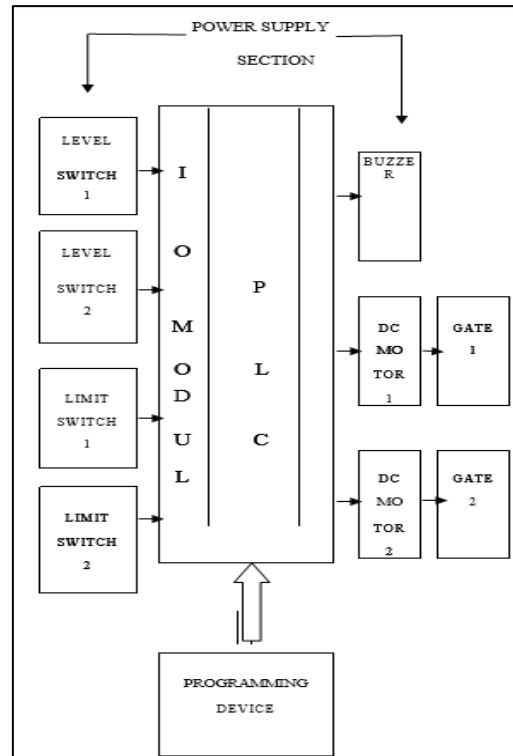

Fig. 2.1: Block Diagram of System using PLC

### III. HARDWARE IMPLEMENTATION

#### A. Programmable Logic Controller (PLC)

This is heart of our proposed system which controls the entire operation of system. This compact Micrologix 1400 PLC, economical programmable controllers offer several I/O configurations. In this PLC, there are 20 input and 12 output are available. This programmable logic control device of inputs are connected in 5 micro switch and this 5 micro switch are connected toward the SMPS (switch mode power supply). SMPS is connected in our system because this PLC are required in 24 volt dc. The micrologix 1400 PLC of output is connected the DC motor. This motor are connected toward relay driver because motor rotation in two direction. The two relay are work as forward direction and two relay are work as reverse direction. This all system are perform by ladder logic. These PLCs were programmed in "ladder logic", which strongly resembles a schematic diagram of relay logic. **Ladder logic** is a programming languages, that represents a program by a graphical diagram based on the circuit diagrams of relay logic hardware. It is primarily used to develop software for programmable logic controllers (PLCs) used in industrial control applications.

#### B. Sensing Element

The sensing elements used here are float switches.

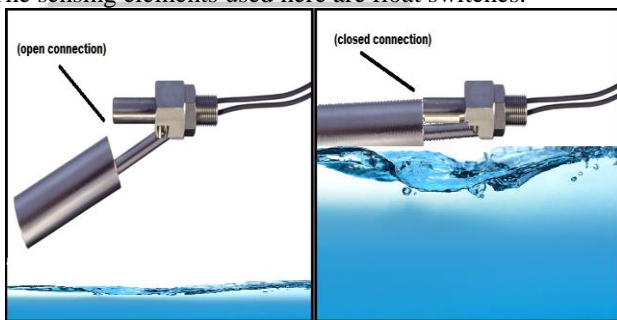

Fig. 2.2: Float switches

#### C. Gate Control

In gate control assembly there are two doors are used in our proposed system. One gate is used for prior level of water in dam which depends on water level detected by level switch 1. And another gate is used for extreme high level of water in dam which depends on level switch 2. The closing and opening of gate is achieved by the dc motor, the motor shaft is connected with the geared belt which placed on gate assembly. The opening of gate also control by timer with required time application. When the gate is fully opened during this stop action of gate will controlled by limit switch. As gate touches the limit switch the trigger plus is applied to the PLC which stops the motor.



Fig. 3.1: Gate Control Assembly with Motor & Limit Switches

Fig 3.1 shows actual arrangement of dam model where brushless DC motor is used to open or close the gate. An additional feature of limit switches is also provided for inspecting proper movement of gate. There are two limit switches attached one at top and another at bottom. The supply to the motor is given through these limit switches. Whenever the gate is opening then till it touches the switch its movement will be on but as soon as it touches the switch then the supply to motor is cut and the gate movement stops. Similarly the mechanism works while closing of gates. This feature monitors the proper operation of dam gates.

#### D. LED & Buzzer

The LEDs are used to show the water level in the reservoir and also it will alert the operator regarding flood. The buzzer will alert the operator as well as others before opening of the gates.

#### E. Motor Driving Circuit



Fig. 3.2: Motor Driving Circuit with Relays

Fig 3.2 shows the motor driver circuit using electromagnetic relays. Four SPDT relays are used one for opening the gate, one for closing the gate, one to turn 'ON' the buzzer/alarm and last one for future use.

#### IV. OPERATION

- a) In normal operating condition when the water is at normal level no action will be taken place and the LO level indicator will glow.
- b) When water level rises and reaches to the 1st level sensor, then an indicator will indicate the water level and buzzer starts sounding. After 10sec of buzzer sound Gate 1 will start automatically and when it reaches to the top limit switch motor will stop lifting the gate.
- c) When water level reaches to 2nd level sensor, then the warning indicator will glow and buzzer starts sounding. After 10sec of buzzer sound gate 2 starts opening and when reaches top limit switch motor will stop lifting.
- d) Gate closing process takes place when water level decrease below level sensors.
- e) When water drops below 2nd sensor Gate 2 closes and motor stopping action of motor will be through limit switch.
- f) When water drops below 1st level sensor Gate 1 closes and motor stopping action will be through limit switches.

#### V. CONCLUSIONS

The system discussed here is based on Programmable Logic Controller having powerful capabilities to tackle number of input and output devices. Here it is used in monitoring water levels into the canal and accordingly control water distribution process in the fields. This helps to suffice irrigation requirements for all farms as it is expandable system. It reduces manual work and improves efficiency for water distribution.

#### VI. FUTURE DEVELOPMENTS

- a) SCADA system can be implemented for monitoring and control from control room.
- b) To enhance the sophistication of this process we can make use of level transmitter and standalone PID controller. This system is opening and closing with in particular stages of gates.
- c) The level transmitter can be used of RFID devices for wireless communication along with the PLC. In this system we are use also GPS .Global position system are indicating for particular person will receiving message and alert through mobile.
- d) Authentication process of SO (section officer) are developed to perform of flood and sprinkler irrigation.

#### REFERENCE

- [1] D.K. Roy & M. H. Ansari, International Journal of Environmental Research and Development, 4, 371-374, (2014).
- [2] Mahesh Nandaniya, International Journal of Emerging Trends in Electrical and Electronics, 1, 32-39, (2013).
- [3] <http://www.youtube.com/watch?v=gIXnERh5LGM>

- [4] R. B. Shah, H. N. Kapse & H. N. Parikh\* PLC based system for effective water distribution from Canals.
- [5] Syed Sheraz Mohani, Syed Muhammad Umar Talha, Syed Hassan Ahmed and Mansoor Ebrahim, 'Design for Irrigation and Monitoring System of an Automated Dam', 'Proceedings of the MultiConference of Engineers and Computer Scientists 2012 Vol II, IMECS 2012, March 14-16, 2012, and Hong Kong.
- [6] <http://www.montanhydraulik.in/montanhydraulik-india-en-civil-engineering-references-indira-sagar-dam.html> this web provides the detailed information of the Montanhydraulik industry that implement PLC based Dam Projects.
- [7] <http://www.montanhydraulik.in/montanhydraulik-india-en-civil-engineering-references-indira-sagar-dam.html> this web provides the detailed information of the Montanhydraulik industry that implement PLC based Dam Projects.