

# Attribute of Electric Power System using D-Statcom MATLAB Simulation

Tejaskumar A. Rewatkar<sup>1</sup> Dr.Ashok Kumar Jhala<sup>2</sup> Prof. Pramod Rathore<sup>3</sup>

<sup>2</sup>Head of Dept. <sup>3</sup>Lecture

<sup>1,2,3</sup>Department of Electrical Engineering

<sup>1,2,3</sup>RKDF Collage Of Engineering, Bhopal(MP),India

**Abstract**— Maximum AC loads reactive power, low power quality in the power system. DSTATCOM is a compensation device that is used to control the flow of reactive power distribution systems. The full bottom compensation compensators and the electronic application power compensation devices presented here and using the DSTATCOM compensation model are also discussed. Detailed modeling and simulations of different control strategies are presented and implemented along with the simulations needed in Simulink with MATLAB toolbox simpler systems. PI controllers are used for modeling and discussion. Simulation results are analyzed and many other second load studies DSTATCOM Simulink models and the results of the resistive, inductive and capacitive simulation are studied widely.

**Key words:** D-STATCOM, Voltage Dip, Power Standard, Strategy of Analysis, SIMULINK, Reactive Power

## I. INTRODUCTION

In the early days of power transmission for the problems of the 19th century, such as voltage deviation during load variations and the limited transfer of power imbalances observed due to reactive power. Most AC loads reactive power due to the presence of ballast. Intense reactive energy consumption results in low voltage quality. Today, these issues are even greater in reliable and secure supply in the world of globalization and privatization of power supply systems and energy transfer impact. The development of fast and secure semiconductor devices (GTO and IGBT) has allowed us to introduce new electronic power configurations into power transmission tasks and load flow control. FACTS devices provide fast and reliable control of the transmission parameters, ie, voltage, line impedance, and phase angle between the final voltage and the final voltage transport reception. On the other hand the cost is for low voltage power Distribution and improvement of poor quality and reliability of supply that affects sensitive loads. Custom power devices are very similar to Factos. The most popular power devices are DSTATCOM, UPQC, DVR including DSTATCOM is well known and can provide a cost effective solution for reactive power compensation and imbalance in the distribution system.

DSTATCOM performance depends on the control algorithm, ie the extraction of existing components. To this end, there are many control schemes, which are described in the literature, and some of them are instantaneous reactive power theory (IRP), instantaneous compensation, Satic synchronous reference theory (SRF), basis based calculation, and Based on the neural network. Among these control schemes, instantaneous reactive power theory and The most commonly used rotating frame. This document focuses on

the compensation of voltage drop, swelling and momentary interruptions.

Voltage lowering is the most important food quality problem faced by many industries and utilities. It contributes over 80% of the power quality issues (PQs) that exist in power systems. By definition, stress collapse is a reduction in the value of the RMS AC supply voltage for the duration of a half cycle for a few seconds. [1]. Voltage losses are not tolerated by sensitive equipment used in modern industrial plants such as

Process controllers, programmable logic controllers (PLCs), adjustable speed controllers (ASDs) and robotics. It has been reported that the high-intensity discharge lamps used for industrial lighting extinguish 20% undervoltage and industrial equipment such as PLC and ASD are about 10%. [1-5] In this document DSTATCOM is controlled by Power Balance theory (PBT). This equilibrium power theory is modified to compensate for the reactive power and cause the voltage profile to be smooth or attenuate sag voltage. A PSIM-based simulation study of this control strategy is presented for DSTATCOM. The simulation results demonstrate the effectiveness of this control algorithm for reactive power compensation and voltage stress mitigation.

## II. DISTRIBUTED STATIC COMPENSATOR (DSTATCOM)

D-STATCOM (distributed static compensator) is a parallel voltage regulator, which is shown schematically in Figure 1, consists of a voltage converter filter, a parallel DC transformer storage device connected to the distribution network via a transformer Of coupling. The voltage generator converts the DC voltage through the storage device to a set of AC three-phase output voltages. These voltages are in phase and coupled to the AC system via the coupling transformer ballast. D-STATCOM The appropriate phase adjustment and output voltage amplitude effectively control the active and reactive power exchange between the D-STATCOM and AC system. This configuration allows the device to absorb or generate controllable active and reactive power. The VSC connected in parallel with the air conditioning system has a multi-topology that can be used in three very different purposes:

- 1) Regulating voltage and reactive power compensation;
- 2) power factor correction
- 3) Elimination of harmonic currents.

Here DSTATCOM is controlled by the balance of power theory (PBT). This power theory of balance is modified to compensate for the reactive power and cause the voltage profile to be smooth or to lower the voltage drop. A PSIM-based simulation study of this control strategy is presented for DSTATCOM. The simulation results To demonstrate the effectiveness of this control algorithm For compensation of reactive power and voltage mitigation.

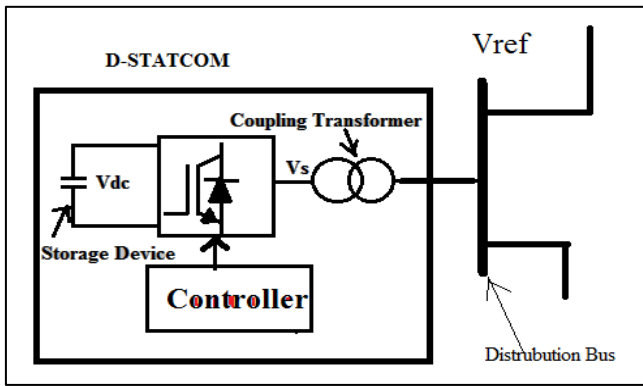

Fig. 1: Schematic diagram of a DSTATCOM

DSTATCOM components: DSTATCOM involves Mainly three parts:-

- 1) IGBT or GTO based converters These inverters are used to create an adjustable output voltage wave at amplitude angle and phase to produce delayed or delayed reactive current, depending on the compensation required.
- 2) L-C filter : The LC filter is used to reduce harmonics and corresponds to the output impedance of the inverter to allow multiple inverters in parallel to share power. The LC filter is chosen depending on the type of system and the harmonics in the output of the inverter.
- 3) Control block: A control block that switches the Pure Wave D-STATCOM modules as required is used. They can control external devices as mechanically switched capacitors. These control blocks are designed based on different theories and control algorithms such as instant PQ theory, synchronous plot theory, etc. All of these different algorithms are discussed in the next chapter.

### III. CONFIGURATION AND OPERATION OF DSTATCOM

When used in low voltage distribution systems, static compensator (STATCOM) is identified as STATCOM (DSTATCOM) distribution. DSTATCOMs commonly used to generate or absorb reactive power. The D-STATCOM refers to the phase power electronics and related derivative devices. It is connected close to the load distribution systems. The main components of a DSTATCOM shown in Figure 1. It consists of a DC capacitor, three three-phase inverters (IGBT, Thyristor), AC filter, adaptive transformer and control strategy [5]. The basic DSTATCOM electronic block is the inverter voltage that converts a DC input voltage to the fundamental frequency output of the three-phase voltage.

### IV. MODELLING AND SIMULATION OF STATCOM WITH POWER SYSTEM

The voltage on the capacitor can be adjusted by checking the phase of Angular difference between line voltage and VSC voltage. If the phase angle The line voltage is taken as a reference, the phase angle of the VSC voltage is the Like the trigger angle of the VSC. DC voltage decreases and reactive Energy flows into STATCOM if the cooking angles are slightly advanced. Conversely, if the cooking angles are slightly squeezed, the voltage increases And STATCOM reactive power provided to the bus. Checking the shot VSC

angles, reactive power can be generated or absorbed by STATCOM and voltage regulation can be achieved. A DC capacitor is Used as source of VSC. DC source sometimes connect Parallel to the condenser that sends more power to the capacitor active During transient conditions. This voltage source converter is connected to Transmission line through a shunt transformer where the voltage is Vdc The condenser current, K is the modulation gain and '□' is the injected voltage

Phase angle. STATCOM is a VSC and condenser. The VSC STATCOM is modeled in 3 IGBT connection arms bridge. Each IGBT is parallel to a diode. The converter output It should be a sine wave. To obtain sinusoidal output in the converter A triangular sinusoidal PWM output at the IGBT ports is given. When the IGBT is 'ON', the drive will act as an inverter and DC capacitor The voltage is reversed by three-phase alternating current. During the "OFF" period the IGBT, the The converter will act as an uncontrolled full wave rectifier and the condenser obtained Loaded to the maximum line voltage value.

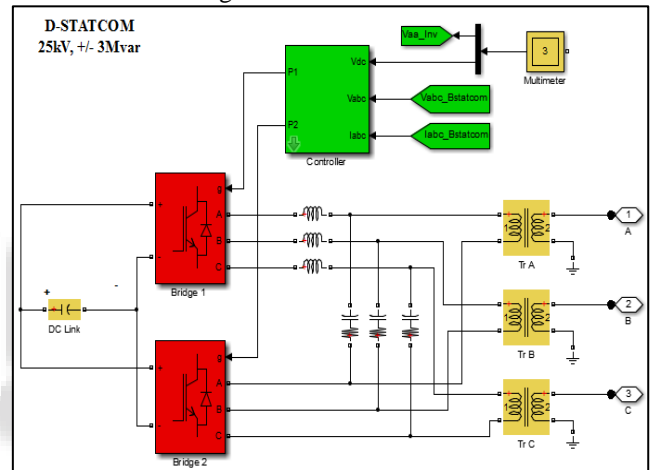
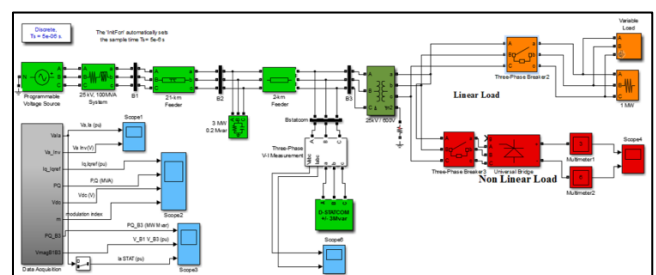

Fig. 2: MATLAB model of DSTATCOM circuit.

### V. SIMULINK MODEL OF THE SYSTEM



### VI. SIMULATION RESULTS

In this document, performance of VSC based power devices acts as a voltage regulator is investigated. It is also assumed that the inverter is directly controlled (that is, the angular position and the amplitude of the output voltage are controllable by appropriate on / off signals) to measure the effective voltage and current required at the load point. The DSTATCOM is commonly used for voltage sags mitigation and harmonic elimination at the point of connection. The dynamic response of 25 kV, +/- 3Mvar DSTATCOM is obtained by the step variation of the source voltage shown in Figure 5. The source voltage is initially maintained at 1PU

after a transient lasts about  $t = 0.1$ sec. During this time, DSTATCOM does not provide or absorb reactive power. At  $t = 0.2$  s, the source voltage increased by 6% to 1.06 processing units. This results in  $I_q$  becoming negative and DSTATCOM compensates for this increase in voltage by absorbing reactive power  $Q = +3$ Mvar (inductively). At  $t = 0.3$  s, the source voltage is reduced by 6% compared to the basal at 0.94 processing units

**A. Result for Nonlinear Load**

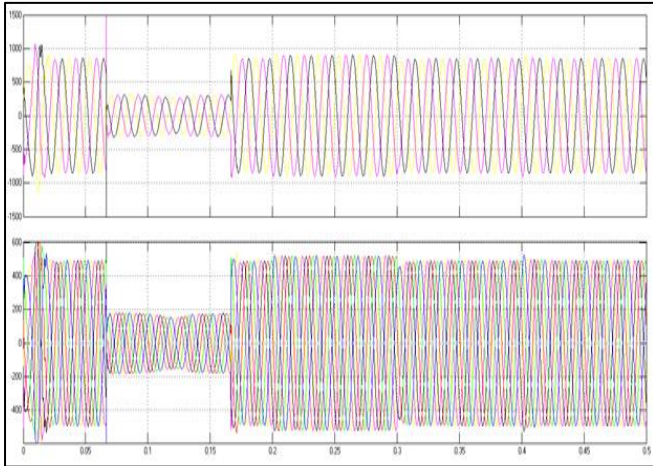

Fig. 4: Non Linear Load Output

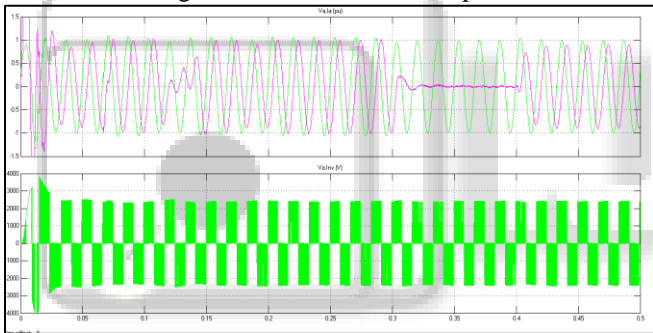

Fig. 5: Scope 1 Simulation Result

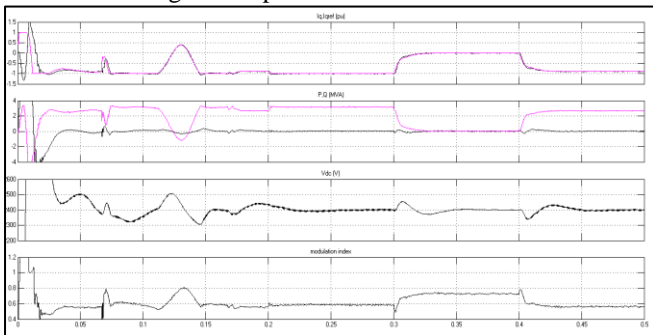

Fig. 6: Scope 2 Simulation Result

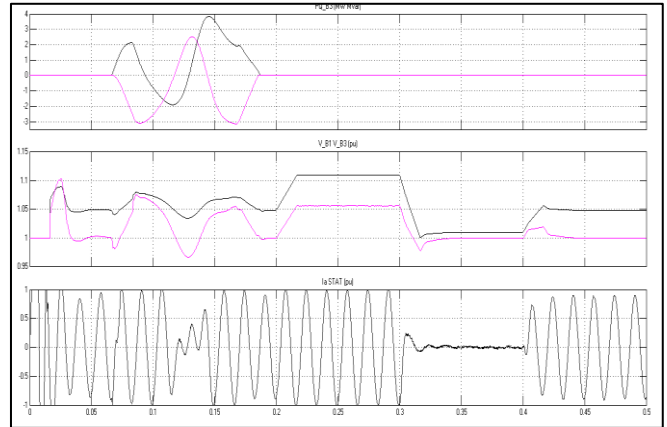

Fig. 7: Scope 3 Simulation Result

**B. Result for Unbalance Load**

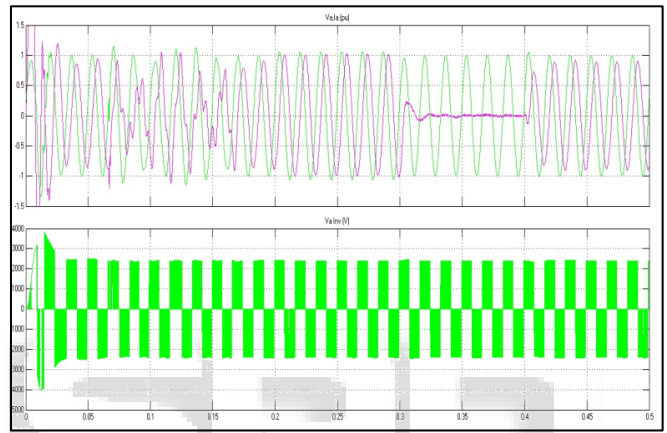

Fig. 8: Scope 1 Simulation Result

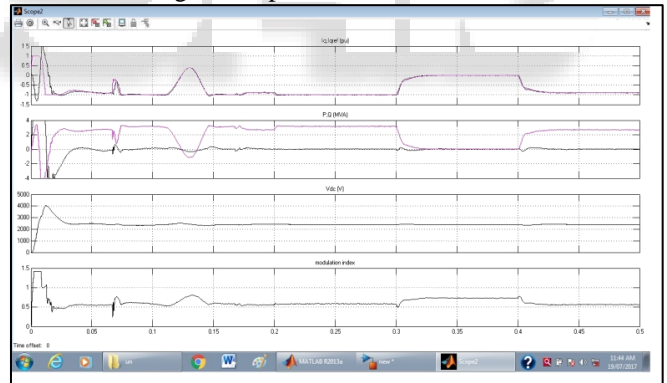

Fig. 9: Scope 2 Simulation Result



Fig. 10: RLC Load MultiMeter Voltage and Current

## VII. CONCLUSION

This paper has presented power quality issues such as voltage drops, voltage interruption, and swelling. The purpose of this work is to study the performance of D-STATCOM to mitigate the voltage drop, interruptions, and improve power quality in the non-linear load distribution network. The search is carried out under different conditions for nonlinear loading. This research work consists of systems energy distribution systems with and without DSTATCOM. Power factor with respect to the source side and load. Therefore, we can conclude that D-STATCOM effectively improves the quality of the non-linear load distribution network.

## ACKNOWLEDGMENT

I would like to thank Dr. Ashokkumar Jhala for technical support and helpful discussions about MATLAB software programming

## REFERENCES

- [1] Mohamed A. Kabeel, "A Modified DSTATCOM Topology for Power Quality Enhancement", Published in: Power Systems Conference (MEPCON), 2016 Eighteenth International Middle East, Date of Conference: 27-29 Dec. 2016, Date Added to IEEE Xplore : 02 February 2017, Conference Location: Cairo, Egypt 978-1-4673-9063-7/16 ©2016 IEEE.
- [2] K. R. Padiyar, "FACTS Controllers in Power Transmission and Distribution," New Age International (P) Limited, Publishers, New Delhi, 2007.
- [3] H. Akagi, E.H. Watanabe and M. Aredes, "Instantaneous power theory and application to power conditioning," Jhon Wiley & sons, New Jersey, USA, 2007.
- [4] Antonio Moreno-Munoz, "Power Quality: Mitigation Technologies in a Distributed Environment", Springer-Verlag London limited, London, 2007.
- [5] Angelo Baghini, "Handbook on power quality," John Wiley & Sons, New Jersey, USA, 2008.
- [6] Deepika Masand, Shailendra Jain "Control Algorithms for Distribution Static Compensator" Dept. Of Electrical Engineering National Institute of Technology, Bhopal (MP), India.
- [7] Haque, M.H., "Compensation Of Distribution Systems Voltage sags by DVR and D-STATCOM", Power Tech Proceedings, 2001 IEEE Porto, Volume 1, PP.10-13, September 2001.
- [8] R.Meinski, R.Pawelek and I.Wasiak, "Shunt Compensation For Power Quality Improvement Using a STATCOM controller Modelling and Simulation", IEEE Proce, Volume 151, No. 2, March 2004.
- [9] IEEE Std 1159-1995, "Recommended Practice for Monitoring Electric Power Quality," IEEE Standards Coordinating Committee 22 on Power Quality, New York, 1995.
- [10] Amir H. N., "Flexible AC transmission systems -theory, control and simulation of the STATCOM and SSSC", Magister thesis, University of New Brunswick, 2003.
- [11] John J., Paserba., Masatoshi Takeda., "FACTS and custom power equipment for the
- [12] enhancement of power transmission system performance and power quality", Sym. Spec. Elec. Ope. Expa. Plan, 2000 (VII SEPOPE) Curitiba, p. 21-26.
- [13] Hariyani M., "Voltage stability with the help of D-STATCOM", Nat. Conf. Rec. Tren. Eng. Tech., B.V.M. Engineering College, V.V. Nagar, Gujarat, India, 13-14 May, 2011
- [14] Mithilesh K. K., Srivastava S. K., "Enhancement in voltage stability and reactive power compensation using D-Statcom", Int. J. Eng. Res. Tech. (IJERT), 2012, 1(7), ISSN: 2278-0181