

Smart Generator Switching and Fuel Monitoring System Based on WSN Technology

Neelam Tiwari¹ Dr. A. K. D. Dwivedi²

^{1,2}Department of Electronics & Information Technology

^{1,2}National Institute of Electronics & Information Technology, Gorakhpur, India

Abstract— The rapid progress in the field of wireless communication and embedded systems has made wireless sensor networks (WSN) technology. In WSN based system, whole system is divided in to two units first is communication unit and second is sensor unit. The communication unit consists of mainly one pair of zigbee S2 modules to provide a wireless communication and the sensor unit consists of mainly ATMEGA328P microcontroller, ultrasonic sensor, LCD display and a buzzer. A WSN consists of many cheaper and smaller wireless sensors, which are capable of collecting and processing environmental information, and communicating with neighboring nodes in the wireless medium. In this paper, we propose an architecture for monitoring of fuel level and switching of smart generator using wireless sensor network (WSN) technology. For establishment of WSN technology, ZigBee/IEEE 802.15.4 protocols [1] are used. The proposed model based on WSN technology has many of the advantages such as Low-power consumption, huge network capacity, high reliability, low cost etc. [2]-[7].

Key words: WSN Technology, Switching and Fuel Monitoring

I. INTRODUCTION

There is a growing market of small household generators ranging from 2-3 KVA which can handle the load of a small house comprising of a few fans, lights, a computer and a TV. These generators are cheap and come equipped with a self-start mechanism built into the generator. On the push of a button, the user can start the generator easily. In the cities, normally these generators are used for a short period of time when the power from the grid is not available. When the power from the grid is not available the user starts the generator and connects the load to the generator manually. When the power from the grid becomes available, the user disconnects the generator from the load, turns off the generator and connects the load to the grid manually. Normally this function is performed manually and requires the engagement of the user for turning the generator on and off and the load between the generator and the grid.

In this paper we propose a controller which performs these tasks automatically. The controller monitors the grid voltage and when there is no voltage, the controller disconnects the load from the grid, starts the generator and shifts the load to the generator. The controller keeps on monitoring the grid voltage and when it comes back on the system turns off the generator and transfers the load to the grid. This system is very useful in the high rate of power failure crisis and relieves the user from the tedious task of attending to the generator regularly for continuous availability of power. There are some commercially available systems in the market which cost even more than the price of a household generator and hence are not economical for the users of household generators.

II. EXISTING MODEL

In order to overcome above issue, there had been an automatic transfer switch controller based generator designed. This automatic transfer switch controller contains the commonly available components such as relays, timers, transformers, diodes and capacitors. This controller does not require any programmable components such as microcontroller, FPGA, DSP etc. to perform its function. The process of manually shifting the load on a backup power source such as a generator and back is a cumbersome process and requires the continuous attention of the user and creates a lot of discomfort as well. A simple controller can handle this tedious task automatically. The controller implements the following functions

It Senses the grid voltage and Automatically starts the generator when grid power fails, Automatically stops the generator when grid power resumes and Automatically transfers the load between the generator and the grid.

The block diagram of the automatic controller is shown in the Fig.1. The function of each block and their implementation is explained below.

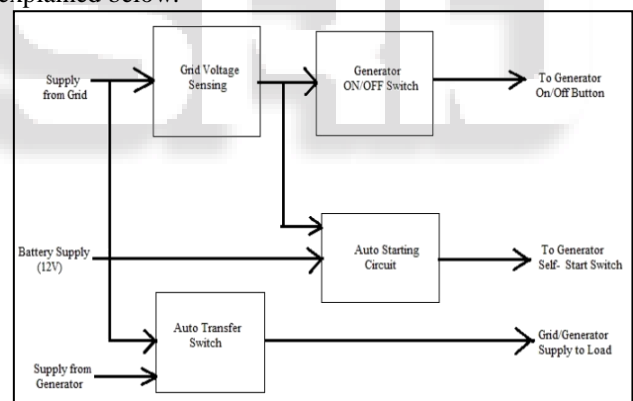

Fig. 1: Block Diagram of the Automatic Controller

A. Schematic and Working Description of Power Generator with ATS Controller

The generator ON/STOP switch open circuits the two wires connected to it when the generator needs to be started and short circuits them when the generator needs to be turned off. A relay can be connected in parallel to this switch. The circuit is shown in the Fig. 2.

A single pole double throw (SPDT) relay has three contact terminals and two coil terminals as shown in Fig.2. The contact terminals are called common (C), normally open (NO) and normally close (NC). When the relay coil is de-energized, the NC terminal is connected to C terminal. When the relay coil is energized, the NO terminal is connected to C terminal.

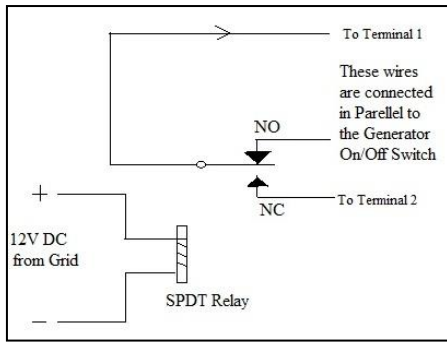

Fig. 2: Schematic of Relay parallel to Generator ON/STOP Switch

The relay coil is energized by 12V DC Grid voltage coming from the sensing circuit. When the voltage is available, the relay coil will be energized. Since when the voltage is available, we want to keep the generator off so we want to keep the wires connected to the generator ON/STOP switch short circuited. Therefore the wires connected to generator ON/STOP switch are connected to NO and C terminals on the relay which are short circuited when the 12V DC Grid voltage is available. When the power failure occurs, the NO terminal is disconnected from the C terminal and the wires are open circuited allowing the generator to be started by the generator start circuit.

The generator is started automatically when the grid power fails and the voltage sensing circuit provides the 0V at its output. Starting the generator requires open circuiting the wires connected to Generator ON/STOP switch which is done by the circuit in Fig.3 and short circuiting the wires connected to self-start switch momentarily done by the circuit shown in Fig. 2.3.

This circuit needs to be placed in parallel with the self-start switch which is normally open circuited. The circuit also provides a path which is normally open in the presence of grid voltage. The path has to be short circuited for a short period of time to engage the self momentarily. This is implemented by using two relays and a timer. The whole circuit is controlled by the 12V DC Grid voltage. When the voltage is present, the path in series with the self-start switch is open circuit. When the grid power fails the path is short circuited for a couple of seconds. When the grid power fails, the coil of Relay1 is de-energized and the path is short circuited engaging the self-start motor. Simultaneously, the coil of Relay2 is also de-energized, closing the path to the timer coil and energizing it through a 12V DC battery. The timer relay used in this circuit changes the state of its contacts after a time delay. The timer has adjustable time duration from 0-10 second that can be changed with the help of the timer knob. Normally the timer is set at 2- 3 seconds.

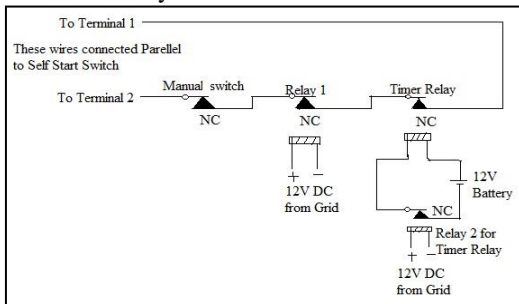

Fig. 3: Schematic of Auto Start Circuit Connected in Series with the Self Start Switch

After the set time, the timer open circuits the path again thus disengaging the self-start motor.

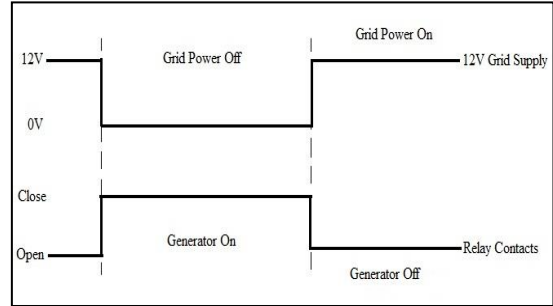

Fig. 4: Timing Diagram for Generator On/Stop Relay

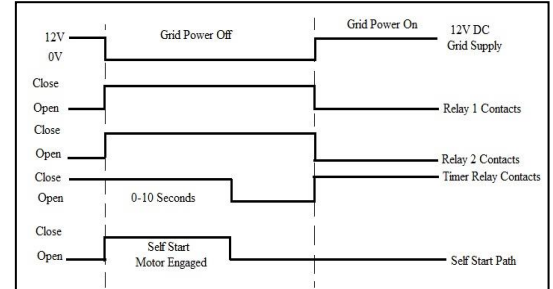

Fig. 5: Timing Diagram for the Generator Auto Start Circuit

III. PROBLEM IDENTIFICATION

There are some limitations are existed in ATS controller based power generator. Which is discussed here that is There is no feedback in the circuit to sense whether the generator has started. It only engages the self-start motor once at the start of the power failure and does not bother to retry if the generator does not start in the first try.

This is one of the possible improvements in the controller. Except this one another limitation is that there is more than one electromechanical relays are used which increase the overall power dissipation as well as size of the whole circuit.

In order to overcome above limitations we have to design a system called WSN based smart generator switching and fuel monitoring system.

IV. PROPOSED MODEL

The proposed model is “Smart generator switching and fuel Monitoring System based on WSN Technology”. Under this model , the generator switching and fuel monitoring and is performed automatically by using ATMEGA328P Microcontroller and zigbee module. The basic block diagram of proposed model is shown in below figure 6.

This project model includes mainly two circuits circuit-1 and circuit-2. Circuit-1 is established at admin side and circuit-2 is located at power generator side. A ATMEGA328P microcontroller with zigbee module is used in both circuits. Here, buzzer is used to indicate the fuel level used in generator when it becomes lesser than a reference threshold level. And a LCD display is used to display the value of fuel level remaining in the generator. Two Zigbee series 2 modules are used to establish wireless connection between circuit-1 and circuit-2. Now , a fuel level detector is used at the power generator end which continuously check the level of fuel used in generator. The output voltage of level detector corresponding to the actual fuel level in the generator is compared with a reference voltage V_t corresponding to a

critical level of fuel through an op-amp comparator. When actual level is lesser than a predefined critical level then an indicating signal is sent by microcontroller used in circuit-2 to microcontroller used in circuit-1 through zigbee modules.

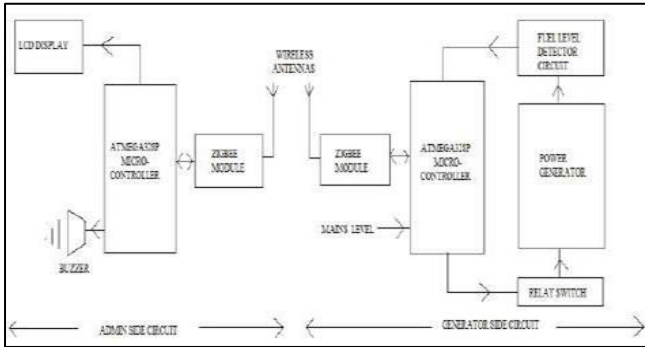

Fig. 6: Block Diagram Of Proposed Model

And buzzer starts to raise up as well as the value of fuel level is also shown in the LCD display. The microcontroller in circuit-1 continuously senses the availability of mains. When mains is not available then microcontroller at generator side operates the relay switch to switch ON the power generator in order to provide power supply to the admin. And similarly, when mains is again available then the generator will be switched off via signal produced by microcontroller in circuit-2.

V. HARDWARE-SOFTWARE CO-DESIGN SIMULATION AND RESULTS

The simulations done with the Proteus software are very motivating as it gives the confidence of correction of our circuit building and programming concepts. Following figure is showing simulation setup for proposed model.

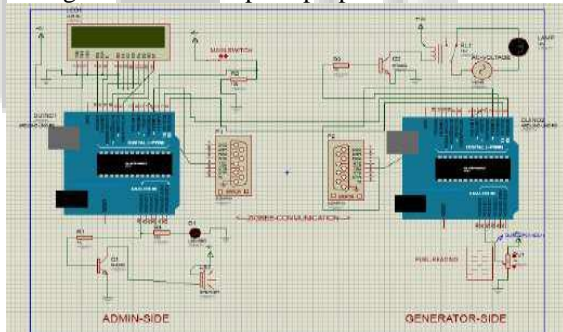

Fig. 7: simulation setup for proposed model

A. When mains is available the relay switch at the generator end is open and generator is switched off as shown in below figure

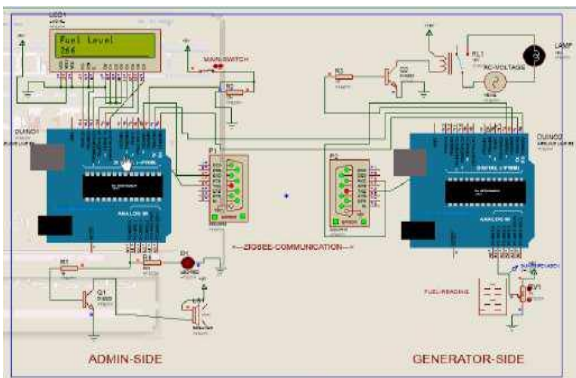

Fig. 8: When Mains is available, Relay Switch is open.

B. When mains is not available then relay switch at the generator side is closed as shown in below figure

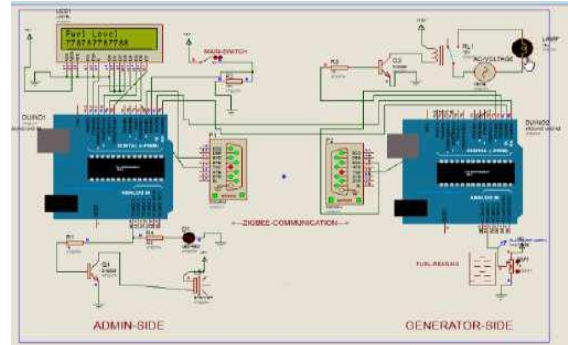

Fig. 9: When Mains is not available, Relay Switch is close.

C. When the fuel level detected by fuel level detector is greater that the reference level L1 then this reading is shown by LCD display at the admin side as shown in below figure

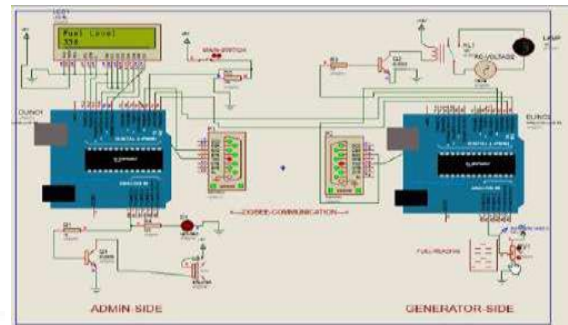

Fig. 10: When fuel level is greater than L1, alarm is not beep.

D. When the fuel level detected by fuel level detector is equal to the reference level L1 then this reading is shown by LCD display as well as alarm starts buzzing at the admin side as shown in below figure

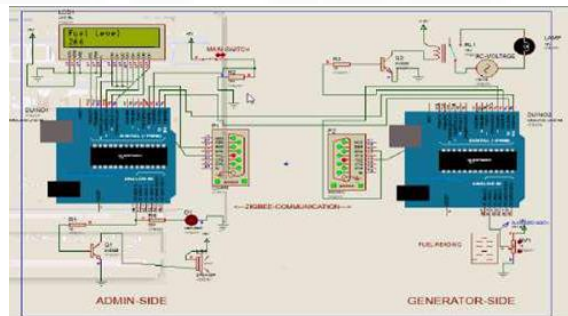

Fig. 11: When fuel level is equal to L1, alarm starts beeping.

VI. COMPARISON OF PROPOSED MODEL WITH EXISTING MODEL

A simple comparison table shows in following figure which shows the comparison of proposed model with existed model[1].

S.No.	Existing Model	Proposed Model
1.	ATmega328P is not used.	ATmega328P is used.
2.	DPDT Relay is used.	DPDT Relay is not used.
3.	3 SPDT Relays are used.	1 SPDT Relays are used.
4.	Circuit Size is larger.	Circuit Size is smaller.

5.	Circuit complexity is high.	Circuit complexity is low.
6.	Power Consumption is 20.4mA.	Power Consumption is 0.75 μ A.
7.	Ambient operating temperature is -40 to 75°C.	Ambient operating temperature is -40 to 85°C.
8.	Feedback is not available.	Feedback is available.

Table 1:

VII. CONCLUSION

This paper introduces an architecture for the smart generator switching and fuel monitoring system based on WSN Technology. It helps in home automation applications like power generator automation. The design presents a switching and fuel monitoring system which consists of mainly two module circuits. One circuit can be installed at the admin side and other circuit can be installed at generator side. The key idea incorporated in the switching of generator corresponding to the availability of mains supply and monitoring of fuel level and provides a visual as well as a sound indication.

Now, we are confident that in coming years our project if used in proper and in efficient direction will become a boon and serve the mankind.

REFERENCES

- [1] Abdul Afram, Abdul Atisam Farooq , A Low Cost Generator Auto Transfer Switch (ATS) Controller for 2-3 KVA Household Generators, Asian Journal Of Engineering, Sciences & Technology, Vol.2, Issue 2.
- [2] Raja Vara Prasad Yerra , Alok Kumar Bharathi, P.Rajalakshmi and U.B.Desai ,WSN Based Power Monitoring in Smart Grids, (ISSNIP) IEEE, Seventh International Conference on,Print ISBN:978-1-4577-0675-2,INSPEC Accession Number:12541389,DOI:10.1109/ISSNIP.2011.6146589 ,401 – 406, 2011.
- [3] C. Bennett and D. Highfill, —Networking AMI smart meters,| in Proc. Energy 2030 Conf. (ENERGY), Atlanta, GA, 2008, pp. 1–8.
- [4] MENG-SHIUAN PAN AND YU-CHEETSENG ,ZIGBEE WIRELESS SENSOR NETWORKS AND THEIR APPLICATIONS ,
- [5] Raja Vara Prasad Yerra , Alok Kumar Bharathi ,P.Rajalakshmi and U.B.Desai ,WSN Based Power Monitoring in Smart Grids, (ISSNIP) IEEE, Seventh International Conference on,Print ISBN:978-1-4577-0675-2,INSPEC Accession Number:12541389,DOI:10.1109/ISSNIP.2011.6146589 ,401 – 406, 2011.
- [6] C. Bennett and D. Highfill, —Networking AMI smart meters,| in Proc. Energy 2030 Conf. (ENERGY), Atlanta, GA, 2008, pp. 1–8.
- [7] Boris Mihajlov And Mitkobogdanoski , Overview And Analysis Of The Performances Of Zigbee Based Wireless Sensor Networks, International Journal Of Computer Applications(0975 – 8887) Ieee, Volume 29–No.12, September 2011.

- [8] Luohui, Control System Of Emergency Generator Set Based On Wireless Sensor Networks (Pacii)Ieee, Doi: 334 - 336, 2009.
- [9] Prof. Pravin R. Lakhe , Wireless Sensor Network Using Zigbee , International Journal Of Engineering Research And Applications (Ijera) Issn: 2248-9622 , 2012.
- [10] Kanchan Kaushal, Taranvir Kaur And Jaspinderkaur ,Zigbee Based Wireless Sensor Networks, (Ijcsit)Ieee , Vol. 5 (6) , 7752-7755, 2014.Ty
- [11] Chong, C. and Kumar, P. “Sensor Networks: Evolution Opportunities and Challenges”, Proceedings of the IEEE, vol.91, No.8, August 2003.
- [12] Kumar, H., Sharma, D., Kar, A. and Mall, R.“Energy Efficient Communication Protocol for Mobile Wireless Sensor Network System” in International Journal of Computer Science and Network Security, Vol.9, No.2, February,2009.