

IoT Based Smart Clothing for Intelligent Outdoor Healthcare Monitoring System for Elders and Heart Disease Patients

M.Arunanand¹ T.Viswanathan²

^{1,2}Department of Electrical and Electronics Engineering

^{1,2}Kumaraguru College of Technology, Coimbatore, India

Abstract— In this paper a completely different approach for patient management using telemonitoring system is conferred. The watching of any human heartbeat rate and fall detection throughout outing needs wearable sensors for the patient. This paper describes a wireless wearable shirt for posture watching during outing or an out-of-doors. For watching patients at distance, many information technologies will be employed to send physiological signals and falling events to a healthcare centre at any time and from anywhere. The topic posture was measured through a sensing element jersey by using associate nursing inductive sensor sewed directly on the material. A systematic review on chronic sicknesses like respiratory organ conditions, high blood pressure, and vas diseases is mentioned here. The incidence of the falling event, pressure level and heart beat rate is at the same time detected using the measuring system sensing element and arm cuff severally. If any abnormalities detected, a notification is shipped to the close health care system. These sensors are integrated within the commonly using artefact. The world Positioning System (GPS) is employed to search out the relative position of the patient throughout the abnormal conditions.

Key words: ADXL335, blood pressure, shirt, GPS, WiFi, IoT, PIC18F77A, telemonitoring

I. INTRODUCTION

By deploying telecommunications technologies to deliver health care and share medical data over a distance, telemedicine aims at providing expert-based treatment to anywhere and at any time health care be required. The event of technologies for health has much enhanced within the last years, particularly within the field of health and health care. The shrinking of the devices is important to supply mobility of the systems for the acquisition and elaboration of important signals. Shrinking and mobility ends up in power consumption issues; for that reason, a lightweight and low-power system could be a real would like for applications during this field. [1].

A potential resolution is to develop a system for getting and analyzing very important signals exploiting smart phone devices. Wireless telemedicine, additionally mentioned as mobile health, that capitalizes on advances of wireless technologies to deliver health care and exchange medical data anyplace and anytime, overcomes most of geographical, temporal, and even structure barriers to facilitate remote diagnosis and observance, and transfer of medical data and records[2]. Nowadays, the continuous value decrease and increase of computing capability, united with the provision of varied embedded sensors and customary communication interfaces, build these devices terribly versatile and a number of other applications, additionally in the health and welfare field, is found in the literature [3]-[13]. Usually, the smart phone embedded

sensors aren't proper or sufficient for very important signals acquisition; for that reason, external sensing supports need to be realised. The measuring system is one of the most common sensors use to observe the body motion. chen et al. [14] placed an accelerometer on the user's waist to find falls. The signal vector magnitude (SVM) and the modification in orientation are calculated and used for detection. Although falls will be detected by their device, some human motions such as sitting down and lying down could result in false alarms. The gyro is another fashionable detector used to observe body motions. A two-axis gyroscope and attached it to the user's chest, waist, and right arm [15]. They detected falls by analyzing the body angel speed and the thigh angel speed. The change in position is detected in terms of abnormal condition change in the sagittal plane for measuring inclination and angular rates of rotations that are integrated to get the positions [16]. This paper presents a system that utilizes ADXL335 motion sensing devices to observe falls. By introducing tiny, non-invasive detector nodes with a wireless network, this project aims to supply a path towards a lot of freelance living for the aged. The system will rule out the non-fall events such as approval, lying down, jumping, and hand clapping during jumping, and cannot recognize them as fall events.

II. BLOOD PRESSURE MONITOR IMPLEMENTATION

Blood pressure monitor is enforced mistreatment free scale medical-oriented Kinetics K53 MCUs and Flexis millimetre devices that feature the subsequent characteristics:

- 16-bit ADC
- 12-bit DAC
- 2x programmable gain operational amplifiers (OPAMP)
- 2x transimpedance amplifiers (TRIAMPs)
- V official generator
- Set of DSP directions as well as Mac (Only K5X Family)
- Multiply and Accumulate (MAC) instruction on MCF51MM

Free scale medical-oriented MCUs scale back the Bill of Materials (BOM) needed for medical applications and supply nice process capabilities ideal for medical instrumentation. Still, some external circuitry is required for pressure sensing and cuff control.

A. Arm Cuff Pressure Control

MED-BPM works using associate oscillometric technique for vital sign measurements. this can be a non-invasive technique that desires associate external arm cuff therefore on impede the patient's arm and notice the heartbeat and heartbeat vital sign. The arm cuff is inflated using associate external air pump controlled with associate MCU GPIO pin, and deflated by activating an safety valve with another

GPIO pin. as a result of the present provided by the USB port (500 mA) is not enough to activate the pump and also the valve (600 mA), those external elements unit activated by exploitation associate external power provide that has adequate current.

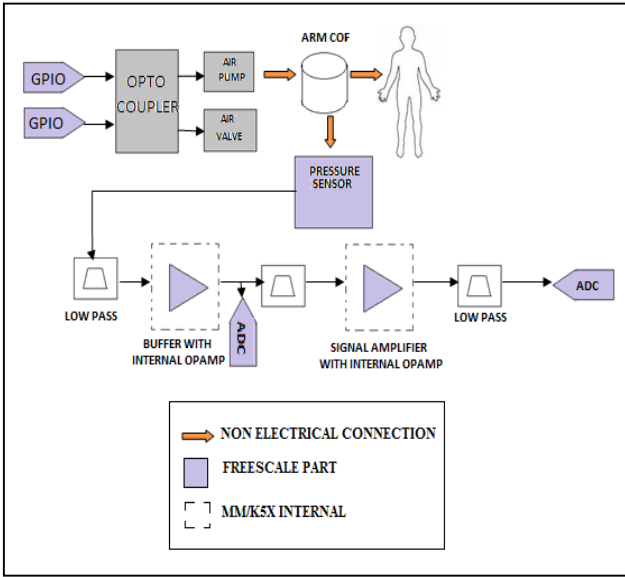

Fig. 1: MED-BPM Block Diagram

An optocoupler is needed for coupling MCU management signals with the components to activate. Fig.2. shows the coupling stage. Output from the optocoupler is connected to a MOSFET operating as a switch, therefore the pump and valve mechanisms are going to be activated successfully.

This stage consists of 3 filters, one buffer circuit, and one non-inverting amplifier (Figure 6). Filters are initial order RC passive kind, and also the cut-off frequency is represented by the subsequent formula.

- 1) a signal is passed through a 10 Hz RC low-pass filter (LPF) composed of a resistor and a capacitor so as to get rid of high-frequency noise.
- 2) Then the signal is passed through a buffer circuit consisting of one Op-Amp in buffer mode to couple the signal to the device. The output from the buffer circuit is wherever the blood pressure measurements are taken.
- 3) The signal is then filtered once more with a two.2 Hz RC high-pass filter that removes high-frequency noise and gets a cleaner signal for amplification.
- 4) This signal is amplified employing a non-inverting amplifier composed by a second Op-Amp and 2 resistors, (100 kΩ and 1 kΩ) generating a gain of 101 therefore cuff oscillations is distinguished higher.
- 5) When this stage, the signal is filtered once more with another ten cps RC LPF therefore high-frequency noise is removed.

B. Software System Model

The MED-BPM demo is predicated on the free scale USB stack and behaves as an USB CDC (Communication Device Class). The demo works mistreatment state machines that execute one state per cycle, to avoid electronic equipment capture and emulating correspondence.

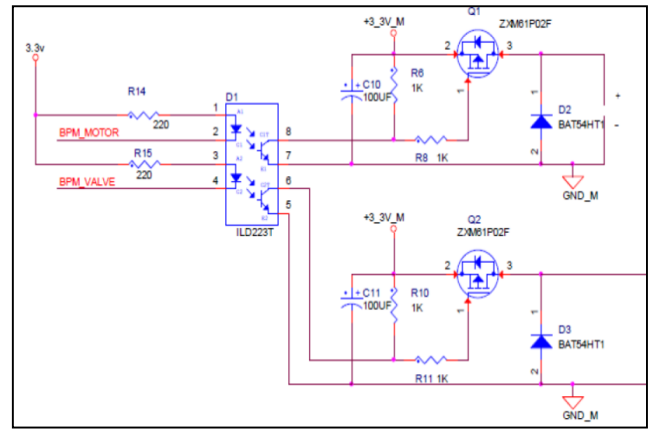

Fig. 2: Coupling Stage

The first step once running MED-BPM demo is to initialize all the peripherals required for demo execution. On the main () perform, perform Init_Sys () is named initial. This perform initializes the clock and interruptions for operating with USB. After this, some needed peripherals for AFEs and also the software system Timer are initialized for initial use. USB is initialized as a CDC (Communication Device Class) therefore communications with the host will begin. After this, the state machines execute in an infinite loop. The subsequent figure depicts the data formatting routine.

III. ACCELEROMETER ADXL335

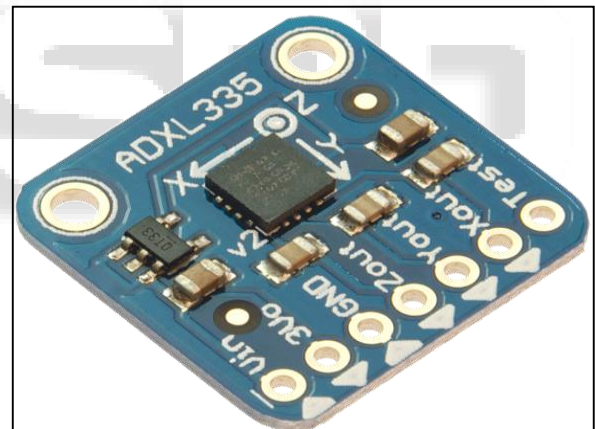

Fig. 3: ADXL335 sensor

The accelerometer used for the gift work is ADXL 335. It is a little, thin, low power complete 3-axis accelerometer with signal conditioned voltage outputs. This device measures acceleration with a minimum fall scale varies of ±3g. It will conjointly live the static acceleration of gravity in tilt sensing applications further as dynamic acceleration ensuing from motion, shock or vibration.

The axes of acceleration sensitivity of the device [6] are shown in figure two. The output voltage will increase once accelerated on the sensitive axis. This device senses the changes in motion and position of an individual. The analog output of the device is directly proportional to the changes in differential capacitance values present in accelerometer. This output is drawn through capacitors and is given to ADC 0804. Figure 3 shows the MEMS device used for current work.

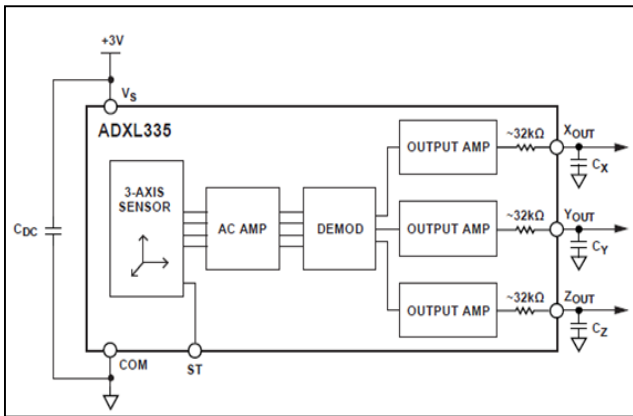

Fig. 4: Functional Block Diagram

IV. GPS

The GPS construct depends on time and conjointly the well-known position of specialized satellites. The satellites carry really stable atomic clocks that are unit synchronous with one another and to ground clocks. Fig.5. shows the GPS module. Any drift from true time maintained on the lowest is corrected daily. Likewise, the satellite locations are identified with nice preciseness. GPS receivers have clocks as well; but, they're sometimes not synchronic with true time, and are less stable. GPS satellites continuously transmit their current time and position. A GPS receiver monitors many satellites works out the precise position of the receiver by solving equations to and its deviation from true time. At a minimum, four satellites should be visible of the receiver for it to calculate four unknown quantities where three positions represents the coordinates and the other points the clock deviation from satellite time.

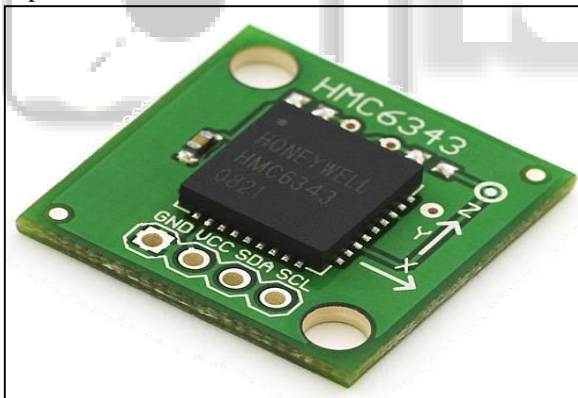

Fig. 5: GPS module

Each GPS satellite regularly broadcasts a proof (carrier wave with modulation) that includes:

- A pseudorandom code (sequence of ones and zeros) that's identified to the receiver. By time-aligning a receiver-generated version and therefore the receiver-measured version of the code, the time of arrival (TOA) of an outlined purpose within the code sequence, referred to as associate epoch, may be found within the receiver time scale.
- A message that has the time of transmission (TOT) of the code epoch (in GPS system time scale) and therefore the satellite position at that point.

Conceptually, the receiver measures the TOAs (according to its own clock) of 4 satellite signals. From the TOAs and therefore the TOTs, the receiver forms four time

of flight (TOF) values, that are (given the speed of light) close to similar to receiver-satellite variations. The receiver then computes its three-dimensional position and clock deviation from the four TOFs. In follow the receiver position (in 3 dimensional Cartesian coordinates with origin at the Earth's centre) and therefore the offset of the receiver clock relative to the GPS time area unit computed at the same time, using the navigation equations to method the TOFs. The receiver's Earth-centered answer location is typically converted to latitude, longitude associated height relative to a non-circular Earth model. The peak might then be any converted to height relative to the geoid (e.g., EGM96) (essentially, mean ocean level). These coordinates is also displayed, e.g., on a moving map show, and/or recorded and/or employed by another system (e.g., a vehicle steering system).

The description higher than is representative of a receiver start-up scenario. Most receivers have a track rule, typically referred to as a tracker that mixes sets of satellite measurements collected at totally different times—in result, taking advantage of the actual fact that sequential receiver positions are sometimes near one another. Once a group of measurements are processed, the tracker predicts the receiver location corresponding to future set of satellite measurements. Once the new measurements area unit collected, the receiver uses a weight theme to mix the new measurements with the tracker prediction. In general, a tracker will (a) improve receiver position and time accuracy; (b) reject dangerous measurements, and (c) estimate receiver speed and direction.

The disadvantage of a tracker is that changes in speed or direction will solely be computed with a delay, which derived direction becomes inaccurate once the gap travelled between 2 position measurements drops below or close to the random error of position measurement. GPS units will use measurements of the Doppler effect of the signals received to figure rate accurately. Additional advanced navigation systems use additional sensors sort of a compass or an inertial navigation system to complement GPS.

V. WIFI

Wi-Fi or WiFi is a technology for wireless local area networking with devices based on the IEEE 802.11 standards. 802.11 is the "radio frequency" needed to transmit Wi-Fi, it was outlined by Vic Hayes who created the IEEE 802.11 committee. Wi-Fi may be a trademark of the Wi-Fi Alliance that restricts the use of the term Wi-Fi Certified to product that with success complete ability certification testing.

Devices that may use Wi-Fi technology embody personal computers, video-game consoles, smart phones, digital cameras, tablet computers, digital audio players and trendy printers. Wi-Fi compatible devices will hook up with the net via a WiFi network and a wireless access point. Such an access purpose (or hotspot) incorporates a measurement of regarding twenty meters (66 feet) inside and a larger outdoors. Hotspot coverage is often as little as one space with walls that block radio waves, or as massive as several sq. kilometres achieved by using multiple overlapping access points.

Depiction of a tool sending info wirelessly to a different device, each connected to the native network, so as to print a document Wi-Fi most ordinarily uses the 2.4 GHz (12 cm) radio frequency and 5 GHz (6 cm) SHF belief radio bands. Having no physical connections, it's additionally prone to attack than wired connections, like LAN.

The IEEE 802.11 standard may be a set of media access control (MAC) and physical layer (PHY) specifications for implementing wireless native space network (WLAN) computer communication within the 2.4, 3.6, 5, and sixty GHz frequency bands. They're created and maintained by the IEEE LAN/MAN Standards Committee (IEEE 802). The bottom version of the quality was discharged in 1997, and has had subsequent amendments. The quality and amendments give the idea for wireless network product using the Wi-Fi complete. Whereas every change is formally revoked once it's incorporated within the latest version of the quality, the corporate world tends to promote to the revisions as a result of they shortly denote capabilities of their product. As a result, within the market place, every revision tends to become its own standard.

VI. MICROCONTROLLER

The Microcontroller used in the current work is PIC18F77A. It is the heart of the developed system that receives the info from the MEMS sensing element and GPS receiver. The sensing element offers the output corresponding to changes in position of associated with an individual carrying it. The GPS offers the position of individual in terms of angular distance and longitudinal values. The purpose of the microcontroller is to method this knowledge comparing with hold on threshold values for traditional condition. If the lean of the person as a result of fall is additional than pre-set worth, then the location of the fallen individual is distributed as text to the close health care centre using the WiFi. The message of the position should even be sent to mobile phones of care taker of fallen subject. The PIC18F77A family are on the market in 40-pin packages. The devices are differentiated from one another in 5 ways:

- 1) Flash program memory- 32 Kbytes
- 2) A/D channels -13
- 3) I/O ports -5 bidirectional ports on forty.
- 4) CCP and enhanced CCP implementation have one standard CCP module and one ECCP module
- 5) Parallel Slave Port

Like all silicon chip PIC18 devices, members of the PIC18F2420/2520/4420/4520 family are on the market as each standard and low-voltage device. Standard devices with increased flash memory, selected with an "F" within the half variety (such as PIC18F2420), accommodate an operating VDD vary of 4.2V to 5.5V. Low-voltage components, selected by "LF" (such as PIC18LF2420), perform over associate extended VDD vary of 2.0V to 5.5V.

VII. METHODOLOGY

The designed flow of human fall detection and rescue in the current work is shown in Fig.7. The accelerometer sensing element is used to track the acceleration changes in 3 orthogonal directions. Figure half-dozen shows the message obtained at receiver finish from GSM module displaying the

modification in z- axis. These values are used to spot user's location. Fig.6 shows the architecture of the Healthcare System

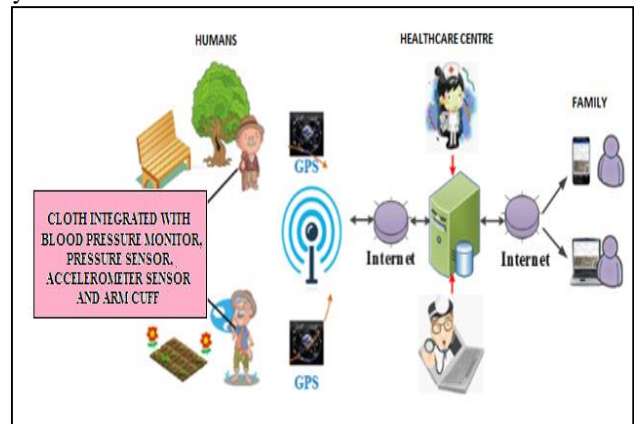

Fig. 6: Architecture of the Healthcare System

The designed system is portable, economical indicating the location of the fall of associate individual. This helps to supply immediate care and treatment. It may be wont to notice fall of senior citizens, fall from a considerable heights by mountaineers, construction workers, Window washers, painters and roofers. The work will be improved by designing the system to detect the various stages of fall.

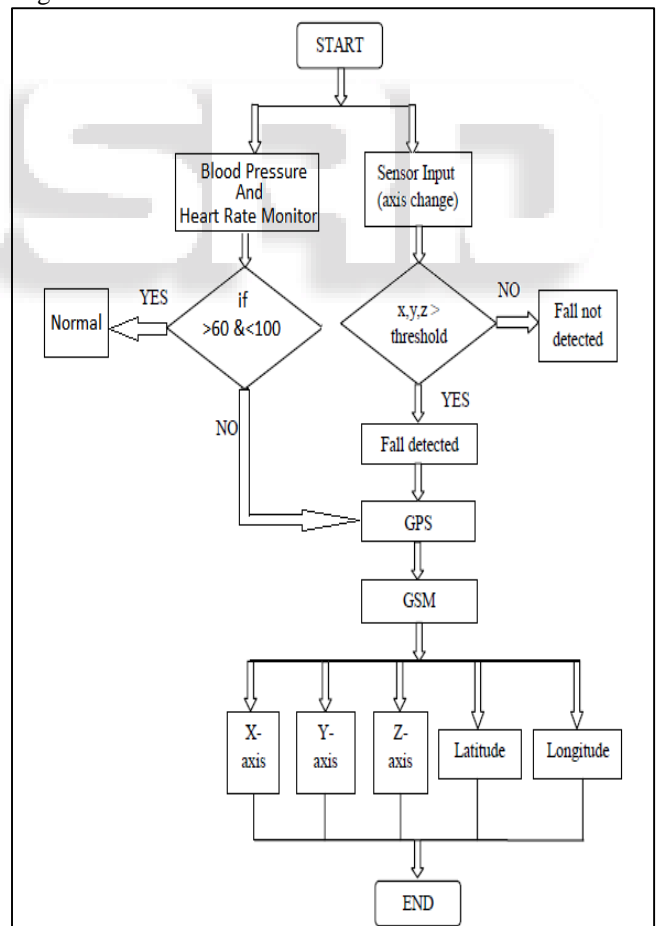

Fig. 7: Flow Diagram

VIII. EXPERIMENTAL RESULTS

The experiment on fall detection relies on observations of aged behaviour. The integrated sensors are associate auxiliary equipment that monitors the GPS and EKG data to

judge the position and examine the physical signals, severally.

Heart Rate	Accelerometer	Status	Response
Normal	Normal	Safe	No Response
Normal	Abnormal	Falling Down Or Lying	No Response
Abnormal	Normal	Abnormal Pulse Or Sensor Removed	Indicate To Patient
Abnormal	Abnormal	Risk	Rescue

Table 1: Default Status and Response State

The fall is determined by the elevation modification of the antenna position on the GPS module. Movement, location variation, and environmental interference present challenges to the productive probability and accuracy of detection. Table. 1. Shows the Default Status and Response State of the proposed system based on the output signals from the blood pressure monitor and accelerometer sensor.

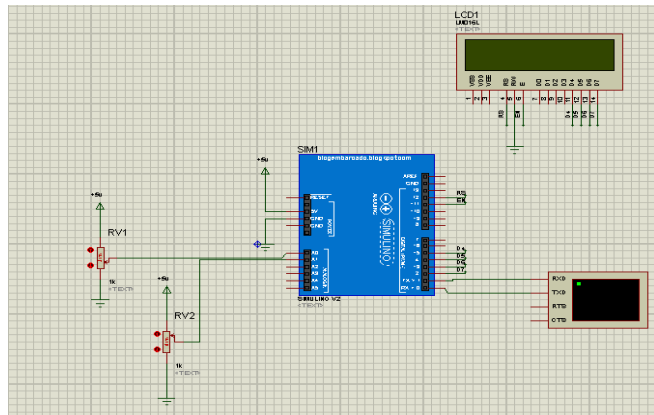

Fig. 8: Initial Circuit Diagram

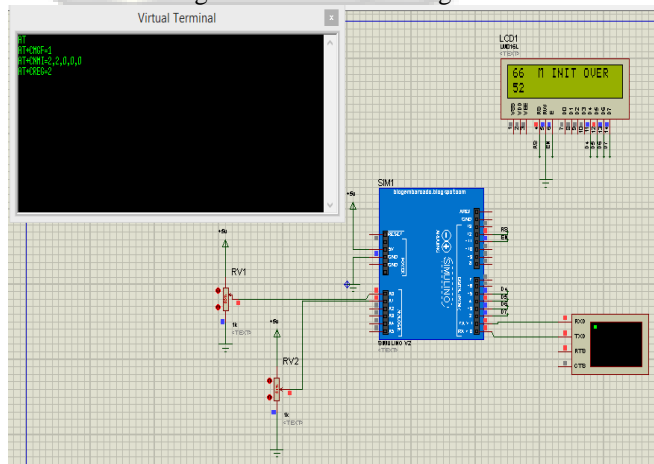

Fig. 9: HBS-normal AM-Normal

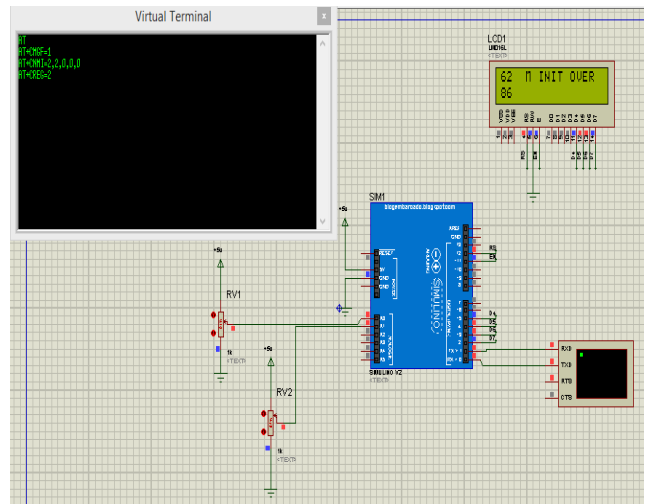

Fig. 10: HBS-normal AM-Abnormal

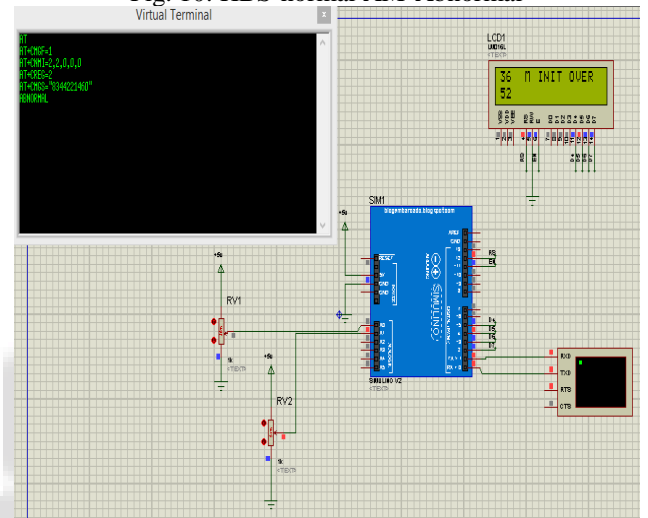

Fig. 11: HBS-Abnormal AM-Normal

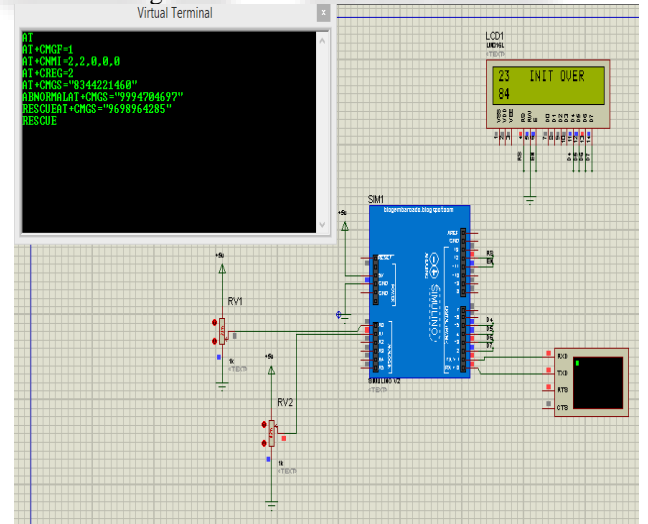

Fig. 12: Hbs-Abnormal Am-Abnormal

IX. CONCLUSION

An intelligent tending system was projected to observe the condition of aged and heart disease persons using varied sensors within the commonly worn cloths. The planned system can assist doctors and nurses in at once perceptive the strength of their aged patients. The sensors were enforced to gather things data and examination signals exploitation GPS and various acquisition sensor modules,

severally. The system will discover whether or not the person is falling by analyzing the collected GPS information. The blood pressure module is associate degree off-line equipment that's accustomed confirms the standing of aged patients. The aid center would be notified that may like for rescue once the time of year was endlessly detected supported the GPS and electrocardiogram interaction observance information. once the fall is detected, GPS (Global Positioning System) locates the precise fall location with the latitude and meridian values. This alert message helps to supply immediate assistance and treatment. fast detection of human fall events has the importance in reducing the speed of mortality and raising the possibilities of survival of the fallen individual.

REFERENCE

- [1] A. Depari, A. Flammini, E. Sisinni, A. Vezzoli, "A Wearable Smartphone-Based System for Electrocardiogram Acquisition", IEEE 978-1-4799-2921-4/14/\$31.00.
- [2] Yanzhang Andnirwan Ansari, Hiroshi Tsunoda, "Wireless Telemedicineservices Over Integratedieee 802.11/Wlan And Ieee 802.16/Wimax Networks", IEEE Wireless Communications, 1536-1284/10
- [3] S. Lee, J. Suh, and H.-D. Park, "Smart Compass-Clinometer: A smartphone application for easy and rapid geological site investigation", Computers and Geosciences, Vol. 61, 2013, pp. 32-42.
- [4] J.C. Yepes and J.J.Yepes, J.R. Martinez, and V.Z. Perez, "Implementation of an Android based teleoperation application for controlling a KUKA-KR6 robot by using sensor fusion", Proc. of 8th Pan American Health Care Exchanges Conference (PAHCE), 2013.
- [5] T. Feitshans and R. Williams, "Smartphones for distributed multimode sensing: Biological and environmental sensing and analysis", Proc. of SPIE - The International Society for Optical Engineering, 2013.
- [6] C.M. De Dominicis, A. Depari, A. Flammini, S. Rinaldi, and E. Sisinni, "Smartphone based localization solution for construction site management", Proc. of Sensors Applications Symposium (SAS), 2013, pp.120-125.
- [7] D.D. Mehta, M. Zañartu, J.H. Van Stan, S.W. Feng, H.A. Cheyne II, and R.E. Hillman, "Smartphone-based detection of voice disorders by longterm monitoring of neck acceleration features", Proc. of International Conference on Body Sensor Networks (BSN), 2013.
- [8] Depari, A. Flammini, S. Rinaldi, and A. Vezzoli, "Multi-sensor system with Bluetooth connectivity for non-invasive measurements of human body physical parameters", Sensors and Actuators A: Physical, in press.
- [9] Q. Li, S. Chen, and J.A. Stankovic, "Multi-modal in-person interaction monitoring using smartphone and on-body sensors", Proc. of International Conference on Body Sensor Networks (BSN), 2013.
- [10] Milenković, M. Milosevic, and E. Jovanov, "Smartphones for smart wheelchairs", Proc. of International Conference on Body Sensor Networks (BSN), 2013.
- [11] H.L. Kennedy, "The Evolution of Ambulatory ECG Monitoring", Progress in Cardiovascular Diseases, 2013.
- [12] T. Pechprasarn and S. Pongnumkul, "Estimation of respiratory rate from smartphone's acceleration data", Proc. of 10th International Conference on Electrical Engineering/Electronics, Computer, Telecommunications and Information Technology (ECTI-CON), 2013.
- [13] Jeon, J. Lee, and J. Choi, "Design and implementation of a wearable ECG system", International Journal of Smart Home, Vol. 7, 2013, pp.61-70.
- [14] Chen, Karric Kwong, D. Chang, 1. Luk, and R. Bajcsy, "Wearable sensors for reliable fall detection," 27th Annual International Conference of the Engineering in Medicine and Biology Society, 2005.
- [15] M. N. Nyan, F. E. H. Tay, and MzeMab, "Application of motion analysis system in pre-impact fall detection," Journal of Biomechanics, vol. 41, issue 10, pp. 2297-2304, 2008.
- [16] Giansanti, V. Macellari, G. Maccioni, and A. Cappozzo, "Is it feasible to reconstruct body segment 3-D position and orientation using accelerometric data?" IEEE Trans. Biomed. Eng., vol. 50, no. 4, pp. 476-483, Apr. 2003.