

## Analysis of Multi-Storeyed Building

**Syed faheemuddin<sup>1</sup> Mohammed Imran<sup>2</sup> NomanFahad<sup>3</sup> Mohammed SaadReyan<sup>4</sup> Prof.Mohammed Khaja Moinuddin<sup>5</sup>**

<sup>1,2,3,4</sup>U.G. Student <sup>5</sup>Assistant Professor

<sup>1,2,3,4,5</sup>Department of Civil Engineering

<sup>1,2,3,4,5</sup>AHCET Hyderabad-501503, India

*Abstract*— We know R.C structural system are most common nowadays in urban regions with multi-bay and multi-storeys, keeping its importance in urban regions especially, A building situated in Hyderabad which is G+2 in height, has been taken for the study, manually the tributary loads distribution of floors to corresponding beams have been done, middle frame of the building has been selected because max amount of floor loads will be transfer on this, all the necessary loads have been worked out and distributed with respect to storey levels. Manually linear static analysis has been done using KANI'S Method of Rotational contribution. The frame also model in SAP2000 V17.3, and all the important results, such as major bending moment major shear force and axial loads have been calculated and a comparison between Manual calculations and SAP2000V17.3 has been made.

**Key words:** Bending Moment, Shear Force, Axial Load

### I. INTRODUCTION

Structural analysis as we know it today, evolved over several thousand years. During this time, many types of structures such as beams, arches, trusses and frames were used in construction for Hundred or even thousands of years before satisfactory methods of analysis were developed for them. While ancient engineers showed some understanding of structural behaviour (with evidenced of their successful construction of bridges, cathedrals, etc.), real progress with the Theory of Structural Analysis occurred only in the past 150 years. In the first half of the 20th century A.D., many complex structural problems were expressed in mathematical form, but sufficient computing power was not available for practically solving the resulting EQUATIONS and/or FORMULAS. This situation continued in the 1940s, when much work was done with MATRICES for analysing aircraft structures. Fortunately, the development of digital computers made practical the use of equations and FORMULAS for these and many other types of Structures, including High Rise Buildings.

Structure is an assemblage of a number of components like slabs, beams, columns, walls, foundations and so on, which remains in equilibrium. It has to satisfy the fundamental criteria of strength, stiffness, economy, durability and compatibility, for its existence. It is generally classified into two categories as Determinate and Indeterminate structures or Redundant Structures. Determinate structures are analysed just by the use of basic equilibrium equations. By this analysis, the unknown reactions are found for the further determination of stresses. Redundant or indeterminate structures are not capable of being analysed by mere use of basic equilibrium equations. Along with the basic equilibrium equations, some extra conditions are required to be used like compatibility

conditions of deformations etc. to get the unknown reactions for drawing bending moment and shear force diagrams.

Example of determinate structures are: simply supported beams, cantilever beams, single and double overhanging beams, three hinged arches, etc. Example of indeterminate structures are: continuous beams, propped cantilever beams, portal frames, multi-bay and multi-storey structural frames etc.

### A. Methods of Linear Elastic Analysis

Elastic analysis deals with the study of strength and behaviour of the members and structure at working loads. Frames can be analysed by various methods. However, the method of analysis adopted depends upon the types of frame, its configuration (portal bay or multi-bay) multi-storeyed frame and Degree of indeterminacy. And the Methods are

- 1) KANI'S Method of Analysis
- 2) Slope Deflection Equation
- 3) Moment Distribution Method
- 4) Substitute Frame Method
- 5) Cantilever Frame Method
- 6) Portal Frame Method
- 7) Column Analogy
- 8) Unit Load Method
- 9) Strain Energy,
- 10) Flexibility coefficient method and stiffness
- 11) Co-efficient method. Etc.

### B. KANI'S Method for Elastic Analysis

This method was introduced by Gasper KANI in 1940's. It involves distributing the unknown fixed end moments of structural members to adjacent joints, in order to satisfy the conditions of continuity of slopes and displacements. The more significant feature of KANI'S method is that the process is self-corrective. Any error at any stage of iteration is corrected in subsequent steps. Framed structures are rarely symmetric and subjected to side sway, hence KANI'S method is best and much simpler than other methods like moment distribution method and slope displacement method.

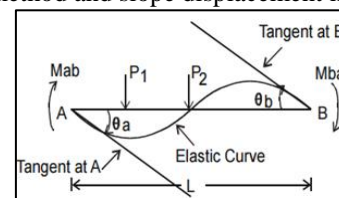

Fig. 1: A general beam element under end moments and loads

General Slope deflection equations are:

$$M_{ab} = M_{Fab} + 2EI/L (-2\theta_a - \theta_b) \quad (1)$$

$$M_{ba} = M_{Fba} + 2EI/L (-\theta_a - 2\theta_b) \quad (2)$$

Equation (1) can be re-written as

$$M_{ab} = M_{Fab} + 2 M'_{ab} + M'_{ba} \quad (3)$$

Where

$M_{Fab}$  = fixed end moment at A due to applied loads, And  
 $M'_{ab}$  = rotation contribution of near end A of member

$$AB = -EI/L(2\theta_a) = -(2EI\theta_a)/L = -2Ek_1\theta_a \quad (4)$$

Where  $[k_1=11/L1]$

$M'_{ba}$  = rotation contribution of far end B of member

AB.

$$\text{So } M'_{ba} = -(2EI\theta_b)/L = -2Ek_1\theta_b \rightarrow (5)$$

1) *Rotational contribution factor (RCF) for Non-sway type analysis*

RCF for Every member =  $-1/2 k / (\sum k)$

Where  $k$ =stiffness of the member being considered and  $\sum k$  is the sum of stiffness of all the members connecting at joint.

2) *Rotational contribution factor for sway type analysis*

In this case in addition to rotation contribution, linear displacement contributions (Sway contributions) of columns of a particular storey are calculated after every cycle as follows:

For the first cycle: Linear Displacement Contribution (LDC) of a column = Linear displacement factor (LDF) of a particular column of a story multiplied by [storey moment + contributions at the ends of columns of that story]

Linear displacement factor (LDF) for columns of a storey =  $-3/2$

$$\text{Linear displacement factor of a column} = -3/2 k / (\sum k)$$

Where  $k$ =stiffness of the column being considered and  $\sum k$  is the sum of stiffness of all columns of that storey.

## II. DESCRIPTION OF THE PROBLEM

A building or edifice is a structure with a roof and walls standing more or less permanently in one place, such as a house or factory. Buildings come in a variety of sizes, shapes and functions, and have been adapted throughout history for a wide number of factors, from building materials available, to weather conditions, to land prices, ground conditions, specific uses and aesthetic reasons. Buildings serve several needs of society – primarily as shelter from weather, security, living space, privacy, to store belongings, and to comfortably live and work. A building as a shelter represents a physical division of the human habitat (a place of comfort and safety) and the outside (a place that at times may be harsh and harmful).

### A. Residential Building

A building should be regarded as residential building when more than half of the floor area is used for dwelling purposes. Other buildings should be regarded as non-residential.

A residential building is taken for the study which has the buildup area of 39'3x40'0, and is situated at Ring Road, Hyderabad. The various components of the building with center line diagram for the selected building for ground and typical storey has shown in the figure-1as follows. Building is G+2 storey.

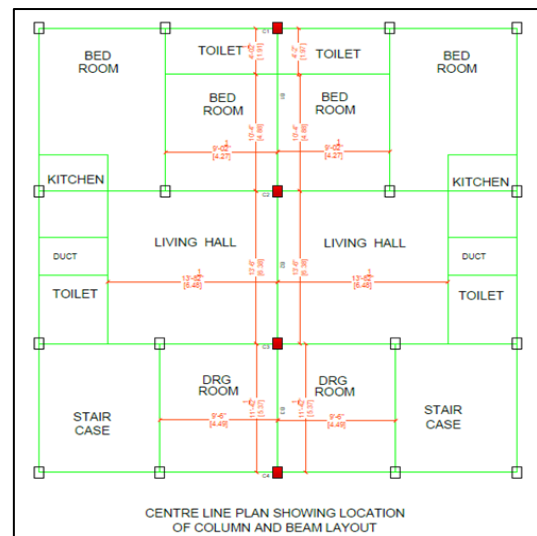

Fig. 1: Layout of the building.

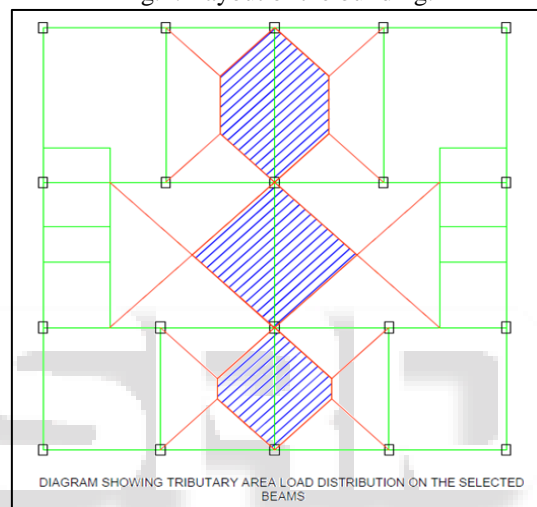

Fig. 2: Tributary Load distribution from slabs to corresponding beams.

## III. DESIGN DATA FOR ANALYSIS

– Slab Thickness	=	125mm
– Storey height	=	3.2m
– Beam size	=	230x400mm
– Column size	=	230x450mm
– Grade of concrete	=	M20
– Grade of steel	=	Fe 415 HYSD
– Live load	=	2.5KN/m <sup>2</sup>
– Floor finish	=	1KN/m <sup>2</sup>
– Wall all around	=	230mm thick
– Density of Brick	=	20KN/m <sup>3</sup>
– Density of Concrete	=	25KN/m <sup>3</sup>
– Live load	=	2.5KN/m <sup>2</sup>
– Floor finish	=	1KN/m <sup>2</sup>

## IV. LOAD DISTRIBUTION TO VARIOUS BEAMS AND STOREYS

Figure.3 shows the transformation of floor load on various beams of a particular storey, depends upon the panel size the load has been transfer in trapezoidal and triangular form, thereby trapezoidal and triangular load have been converted to Equivalent UDL.



Fig. 3: Load transformation from various floors to corresponding beams for Middle Frame.

V. ROTATIONAL CONTRIBUTION FACTOR

Joint	Member	Relative Stiffness (K) = (I/L)	$\sum K$	R.C.F (-0.5 (K/ $\sum K$ ))
B	BA	0.31	0.76	-0.2
	BF	0.14		-0.09
	BC	0.31		-0.2
C	CB	0.31	0.76	-0.2
	CG	0.14		-0.09
	CD	0.31		-0.2
D	DC	0.31	0.45	-0.34
	DH	0.14		-0.16
F	FE	0.31	0.87	-0.18
	FB	0.14		-0.08
	FJ	0.11		-0.06
	FG	0.31		-0.18
G	GF	0.31	0.87	-0.18
	GC	0.14		-0.08
	GK	0.11		-0.06
	GH	0.31		-0.18
H	HG	0.31	0.56	-0.28
	HD	0.14		-0.13
	HI	0.11		-0.1
J	JN	0.14	0.87	-0.08
	JF	0.11		-0.06
	JI	0.31		-0.18
	JK	0.31		-0.18
K	KJ	0.31	0.87	-0.18
	KG	0.11		-0.06
	KO	0.14		-0.08
	KL	0.31		-0.18
L	LK	0.31	0.56	-0.28
	LP	0.14		-0.13
N	NM	0.31	0.76	-0.2
	NJ	0.14		-0.09
	NO	0.31		-0.2
O	ON	0.31	0.76	-0.2
	OK	0.14		-0.09
	OP	0.31		-0.2
P	PO	0.31	0.45	-0.34
	PL	0.14		-0.16

Table 1: Rotational Contribution factor

VI. KANI'S ITERATIVE CYCLES

Fig 4: shows the KANI's Iterative procedure to get the rotational contribution of every joint. the detail cycles chart is presented for convinience.

VII. MODELLING OF FRAME IN SAP2000v17.3

We all know SAP2000 is the highly efficient program to analyse any sort of structures, with any kind of boundary conditions, therefore this software is widely accepted by many of the companies throughout the world for analysis and design of different structures, keeping its importance and result analysis we have compare our total manual analysis with SAP2000 results.

VIII. COMPARISON OF COLUMN MOMENTS

Sl. No	Member End	Results (KN-M)	
		Manual Cal	SAP2000 Results
1	M <sub>AB</sub>	-13.45	-14.19
2	M <sub>BA</sub>	26.9	28.72
3	M <sub>BC</sub>	-34.8	-37.07
4	M <sub>CB</sub>	29.25	32.75
5	M <sub>CD</sub>	-38.88	-39.99
6	M <sub>DC</sub>	54.06	56.44
7	M <sub>EF</sub>	-7.46	-8.24
8	M <sub>FE</sub>	14.92	16.79
9	M <sub>FG</sub>	-20.5	-22.71
10	M <sub>GF</sub>	18.62	21.24
11	M <sub>GH</sub>	-22.11	-24.34
12	M <sub>HG</sub>	27.48	31.23
13	M <sub>IJ</sub>	7.96	8.85
14	M <sub>JI</sub>	-15.92	-17.9
15	M <sub>JK</sub>	21.81	24.2
16	M <sub>KJ</sub>	-19.74	-22.52
17	M <sub>KL</sub>	23.57	26.05
18	M <sub>LK</sub>	-29.47	-33.5
19	M <sub>MN</sub>	12.84	13.68
20	M <sub>NM</sub>	-25.68	-27.51
21	M <sub>NO</sub>	33.28	35.56
22	M <sub>ON</sub>	-28.04	-31.49
23	M <sub>OP</sub>	37.14	38.41
24	M <sub>PO</sub>	-51.48	-54.05

Table 2: Comparison of column moments.

IX. COMPARISON OF BEAM MOMENTS

Sl. No	MEMBER END BM (KN-M)			SPAN BM (KN-M)		
	EN D	MAN CAL	SAP2000	SPAN	MAN CAL	SAP2000
1	M <sub>BF</sub>	-63.09	-65.79	BF	40.57	40.70
2	M <sub>FB</sub>	-91.77	-88.93			
3	M <sub>FJ</sub>	-129.01	-128.43	FJ	68.45	67.81
4	M <sub>JF</sub>	-128.47	-128.03			
5	M <sub>JN</sub>	-88.84	-85.94	JN	38.81	38.87
6	M <sub>NJ</sub>	-60.28	-63.07			
7	M <sub>CG</sub>	-68.98	-72.74	CG	40.57	40.70
8	M <sub>GC</sub>	-87.49	-83.26			
9	M <sub>GK</sub>	-129.59	-128.85	GK	68.45	67.81
10	M <sub>KG</sub>	-129.29	-128.77			
11	M <sub>KO</sub>	-84.54	-80.20	KO	38.81	38.87

12	M <sub>OK</sub>	-65.97	-69.89			
13	M <sub>DH</sub>	-52.73	-56.44	DH	40.57	40.70
14	M <sub>HD</sub>	-98.99	-95.27			
15	M <sub>HL</sub>	-128.09	-126.50	HL	68.45	67.81
16	M <sub>LH</sub>	-127.25	-125.85			
17	M <sub>LP</sub>	-96.09	-92.36	LP	38.81	38.87
18	M <sub>PL</sub>	-50.28	-54.05			

Table 3: Comparison of beam moments

X. COMPARISON OF BEAM SHEAR FORCE

SL. NO	MEM END	RESULT(KN)	
		MAN CAL	SAP2000
1	R <sub>B</sub>	88.72	89.82
2	R <sub>C</sub>	90.75	92.34
3	R <sub>D</sub>	85.2	86.68
4	R <sub>F</sub>	229.16	228.03
5	R <sub>G</sub>	227.09	225.45
6	R <sub>H</sub>	232.7	231.2
7	R <sub>J</sub>	225.21	224.09
8	R <sub>K</sub>	223.25	221.63
9	R <sub>L</sub>	228.6	227.14
10	R <sub>N</sub>	84.98	86.12
11	R <sub>O</sub>	86.98	88.64
12	R <sub>P</sub>	81.5	83.04

Table 4: Comparison of beam Shear Force.

XI. COMPARISON OF COLUMN SHEAR FORCE

Sl. No	MEM END	Result(KN)	
		MAN CAL	SAP2000
1	R <sub>AB</sub>	-12.6	-13.41
2	R <sub>BA</sub>	12.6	13.41
3	R <sub>BC</sub>	-20.01	-21.82
4	R <sub>CB</sub>	20.01	21.82
5	R <sub>CD</sub>	-29.04	-30.14
6	R <sub>DC</sub>	29.04	30.14
7	R <sub>EF</sub>	-6.99	-7.82
8	R <sub>FE</sub>	6.99	7.82
9	R <sub>GF</sub>	12.24	-13.73
10	R <sub>FG</sub>	-12.24	13.73
11	R <sub>GH</sub>	-15.49	-17.36
12	R <sub>HG</sub>	15.49	17.36
13	R <sub>IJ</sub>	7.46	8.36
14	R <sub>JI</sub>	-7.46	-8.36
15	R <sub>JK</sub>	12.98	14.60
16	R <sub>KJ</sub>	-12.98	-14.60
17	R <sub>KL</sub>	16.57	18.61
18	R <sub>LK</sub>	-16.57	-18.61
19	R <sub>MN</sub>	12.03	12.87
20	R <sub>NM</sub>	-12.03	-12.87
21	R <sub>NO</sub>	19.16	20.95
22	R <sub>ON</sub>	-19.16	-20.95
23	R <sub>OP</sub>	27.69	28.89
24	R <sub>PO</sub>	-27.69	-28.89

Table 5: Comparison of Column Shear Force.

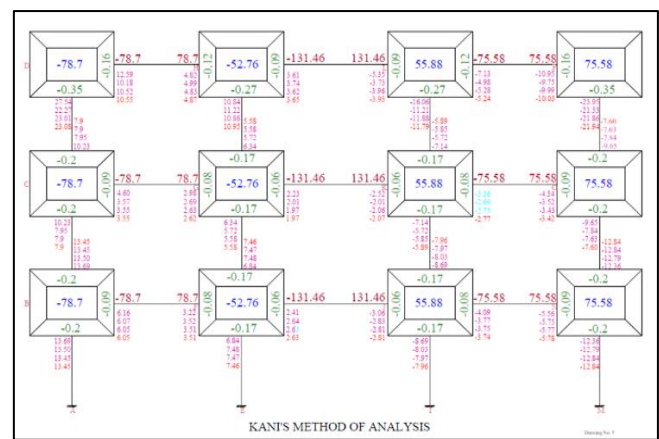

Fig. 4: KANI'S Iterative Cycles

XII. COMPARISON OF COLUMN AXIAL FORCE

COL	MEM	MAN CAL		SAP2000	
		TOP (KN)	BOT (KN)	TOP (KN)	BOT (KN)
1	DC	82.2	93.48	86.68	94.96
	CB	184.23	192.51	187.30	195.58
	BA	281.23	289.51	285.40	293.68
2	HG	232.7	240.98	231.20	239.48
	GF	468.07	476.35	464.93	473.21
	FE	705.51	713.79	701.23	709.51
3	LK	228.6	236.88	227.14	235.42
	KJ	460.13	468.14	457.05	465.33
	JI	693.62	701.9	689.42	697.70
4	PO	81.5	89.78	83.03	91.31
	ON	176.76	185.04	179.95	188.23
	NM	270.02	278.3	274.35	282.63

Table 6: Comparison of Column Axial Force.

XIII. RESULTS AND DISCUSSIONS

The first part of the work is comprising of manual analysis using knows method and second part is analysis from in SAP2000 structural computer program. The same frame which is chosen for the study is model in SAP2000 V15.1, and applied the loading which is calculated by manual means. The accuracy of KANI'S method has compared with SAP2000, the result which are revealed as follows.

- 1) When we compare final end moments of columns of KANI'S method with SAP2000 results only 5.2% of variation in results, SAP2000 is giving 5.2% higher results.
- 2) When we compare final beam end span moments only 4.1% variation in end moments and 0.3% in span moments.
- 3) When we compare beam shear frames force only 1.22% variation in results, SAP2000 is giving only 1.22% higher results.
- 4) Columns shear force are 6.04% higher than manual shear forces.
- 5) Axial loads on column, SAP2000 is giving 5.1% higher axial load than manual for top end of column, and 1.55% higher axial load than manual for bottom end of column.

#### XIV. CONCLUSIONS

From manual analysis by KANI'S method and structural analysis program SAP2000, the following conclusion can be listed as follows:

- 1) KANI'S method is very much easy for analysis of multistoried building frame subjected to gravity loadings as compare with other classical methods.
- 2) When manual calculations compare with SAP2000 results, the results are quite, same, hence for manual analysis KANI'S method of analysis is best suited.
- 3) SAP2000 is a powerful structural analysis and design engine that can be used for all structural problems.
- 4) SAP2000 program can be recommended for analysis of indeterminate rigid plane frames Etc.

#### REFERENCES

- [1] G. Anil, Dr. P. SuvarnarRaju, D. A. Raghavendra, International Journal of Engineering and Applied Sciences (IJEAS), ISSN: 2394-3661, Volume-3, Issue-4, April 2016 [www.ijeas.org](http://www.ijeas.org)
- [2] Prof.Sakshi A., Manchalwar, Akshay S. Puri and VishakhaAswale, International Journal of Science, Engineering and Technology Research (IJSETR), ISSN: 2278 – 7798, Volume 5, Issue 4, April 2016, [www.ijert.org](http://www.ijert.org)
- [3] BadgireUdhav S., Shaikh A.N., Maske Ravi G.International Journal of Engineering Research, ISSN:2319-6890, Volume No.4, Issue No.9, 01 Sept. 2015, [www.ijert.org](http://www.ijert.org)
- [4] Aman, ManjunathNalwadgi, Vishal T, Gajendra, International Research Journal of Engineering and Technology (IRJET), e-ISSN: 2395 -0056, p-ISSN: 2395-0072, Volume: 03 Issue: 06, June-2016, [www.irjet.net](http://www.irjet.net)
- [5] SreekanthGandlaNanabala, Pradeep Kumar Ramancharla, Arunakanthi E, International Journal of Engineering Research & Technology (IJERT), ISSN: 2278-0181, Vol. 3 Issue 9, September- 2014, [www.ijert.org](http://www.ijert.org)
- [6] Manual from CSI for using SAP2000V17.3.