

# Bomb Detection Robot with Pickup and Drop Facility

Tanmay S. Mote<sup>1</sup> Umesh A. Khillare<sup>2</sup> Gaurav R. Ghodke<sup>3</sup> Abhishek R. Sharma<sup>4</sup>  
<sup>1,2,3,4</sup>Department of Computer Engineering  
<sup>1,2,3,4</sup>SIER, Nashik

**Abstract**— In the present situation of many countries; unmanned systems is very important to minimize human losses. So this robot is very useful to do activities like detecting bomb. This project aim is to design and execute the bomb detection with pick up and drop that bomb facility. This robot is fitted with motors. A micro controller is used to control all functions. According to the motor operations the robot will operate as specified in program. Whenever any bomb is detected, the Buzzer will ON. Also there is one camera on the robot to catch live feeds and send that live feed to the operator so if any obstacle come in the way then operator can take preventive measures according to the situation.

**Key words:** Bomb Detection, Drop Facility

## I. INTRODUCTION

This application is within the space of computer programming and embedded systems. There is want for weapons and explosive detection systems in uncontrolled situations have enlarged in recent years. Previously metal detector systems are limited to control areas but they cannot detect plastic explosives. Civilian and military want technologies capable of detection of hidden weapons and explosives at remote distances to increase safety.

In this project we have a aim of detection of a weapons (metals) and there is one metal detector coil on back side of a robot if any suspicious object is detected, then precautions will be taken once bomb is detected that is we can move that object to safer location. This project is incredibly helpful in each crowded public places like bus-stands, parks, auditoriums, this project is very much useful to the police department in order to prevent bomb explosion and prevent antisocial activities in the society.

In this project when robot senses any metal under the metal detector coil, Robot gives buzzer on the site and also to the operator. Robot consists of four motors, which control the side wheels and help in moving forward and backward direction.

## II. SCOPE

The Wireless Bomb Disposal mechanism is an important application, at the user end to manage the mechanism remotely Wireless technology is used. The bomb technician controls the mechanism through this application. Input from the user is given serially over associate degree RF link to the mechanism, wherever it's received, known and relayed to the suitable module. The input to the system is from the user. This input is first processed at the management application, serially transmitted over a communication system. This input is then received at the robot side and processed once more. The output of the system is that the processed signal to the suitable module. This module will be a motor of the bottom of the mechanism or the robotic arm.

## III. OBJECTIVES

- Provide a distant watching application for analysis of a suspicious object (or bomb).
- To provide visual feedback from the position of the object.
- Allow the user to handle the packet with the robotic arm.
- To provide an easy management application.
- If bomb is found then robot will give the buzzer and the signal to the technician.
- Also robot can pick up the bomb and place in disposable box or to the safer location.

## IV. EXISTING SYSTEM

- Robot solely detects the bomb and buzzer on the site only.
- But it's not hearable to Operator.
- Robot only finds the Bomb however not pick the Bomb.
- Robot gets stuck if any obstacle comes in its path.

## V. PROPOSED SYSTEM

- Robot detect the Bomb and buzzers on site and also offer the buzzer to operator.
- And its buzzer is loud to Operator.
- Buzzer used on operator side also.
- The video feed is also use to see the obstacles in the way of a robot
- Robot detect the bomb and can pick up the bomb.

## VI. BLOCK DIAGRAM

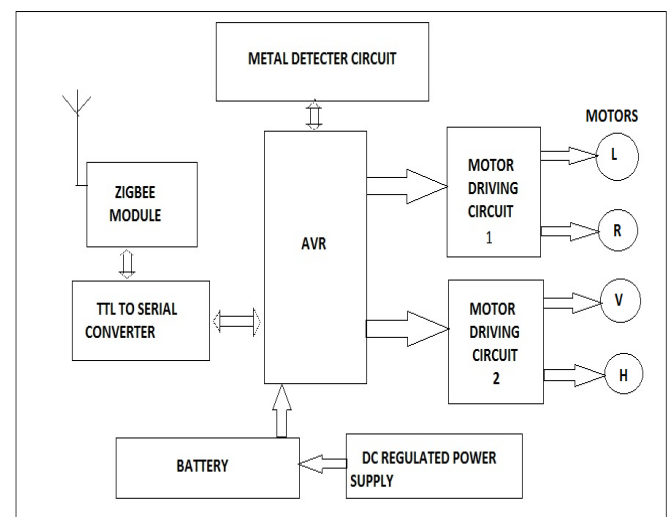

Fig. 1: Robot side module

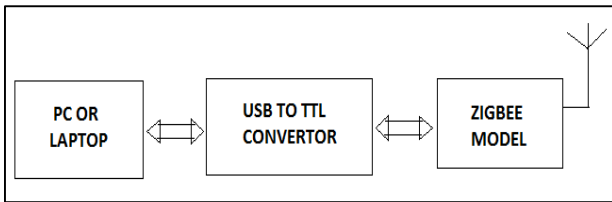

Fig. 2: Controller side module

### VII. SYSTEM REQUIREMENTS

#### 1) Hardware:

- Zigbee modules,
- Metal Detector,
- Motor driver IC,
- DC motors,
- Pick up and place mechanism,
- Camera,
- Battery.

#### 2) Software:

Operating System: window OS XP/higher version.Net framework,

### VIII. RESULTS AND ANALYSIS

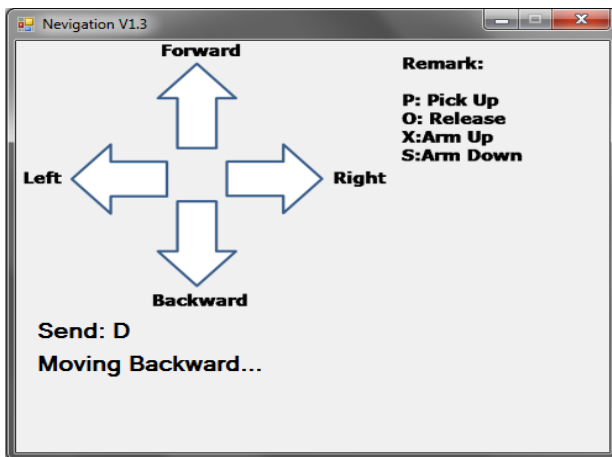

Fig. 3: Moving Backward

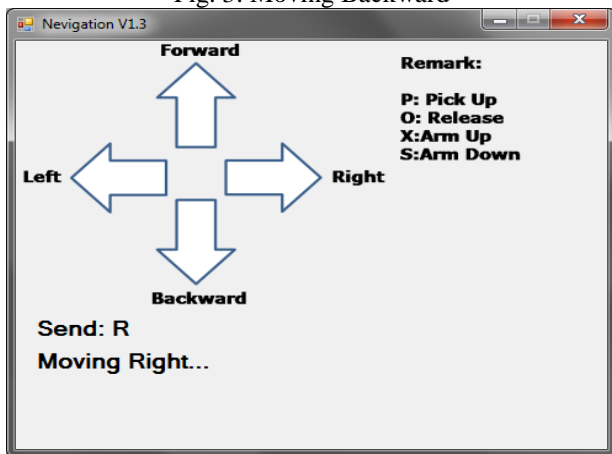

Fig. 4: Moving Right

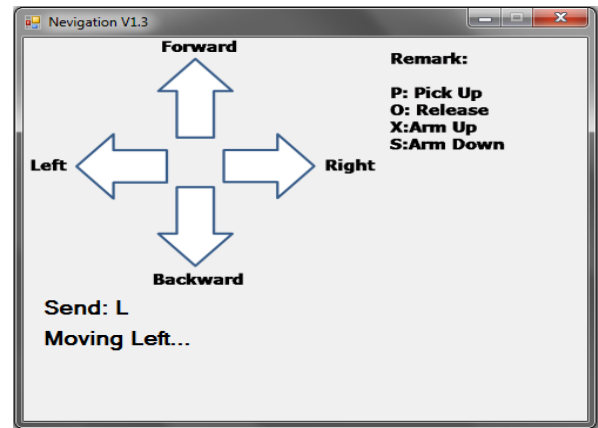

Fig. 5: Moving Left

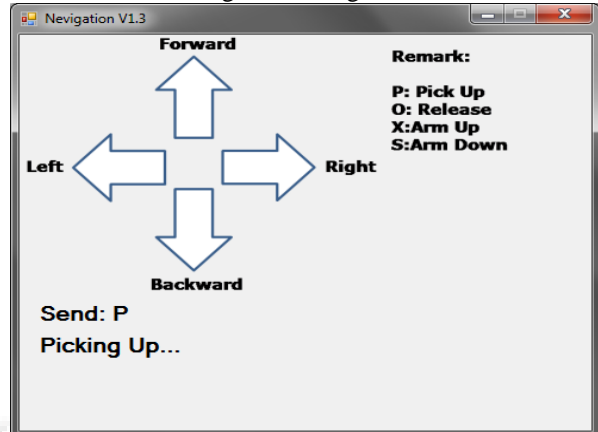

Fig. 6: Picking Up

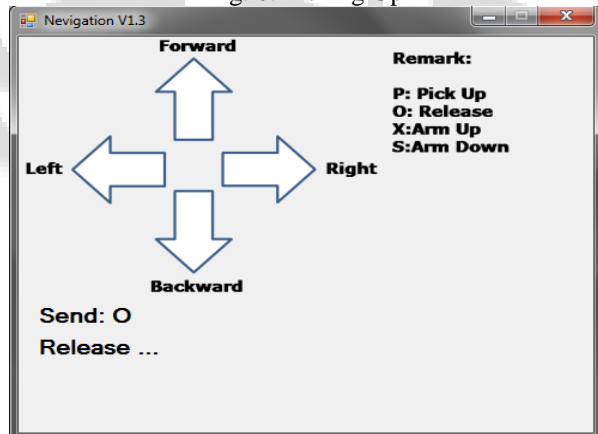

Fig. 7: Releasing

In this project, Robot moves forward, backward, left, right wirelessly. For wireless communication here Zigbee is used. It also has a moving arm for pickup and drop mechanism. On the back side of a robot there is one metal detector coil. If any object comes under that metal detector coil then it gives us the signal. If the metal part is detected so we can know that there is suspicious object. Otherwise it will give the negative signal means object is not suspicious. We can also move that suspicious object to a secure location so it can be checked properly.

### IX. CONCLUSION

The Wireless Bomb Disposal mechanism has been designed in such the simplest way that it will fulfill the requirements of the bomb disposal squad, the military, the police as well as for the companies to handle hot materials.

It has variety applications and may be used in totally different environments and situations. for example, at one place it is employed by the bomb disposal squad, whereas at another instance it is used for handling mines.

#### REFERENCES

- [1] Guoxing Zhan and Weisong Shi, Senior Member, IEEE. LOBOT: affordable, Self-Contained Localization of Small-Sized Ground Robotic Vehicles IEEE TRANSACTIONS ON PARALLEL AND DISTRIBUTED SYSTEMS, VOL. 24, NO. 4, APRIL 2013.
- [2] Rajeev Joshi ,Pratap Chandra Poudel , PankajBhandari. International Journal of Scientific and analysis Publications, Volume 4, Issue 5,May 2014 I ISSN 2250-3153 .
- [3] Ying-Wen Tibeto-Burman, Li-SihShen associate degreeed Zong-Han Li "Design and Implementation of an Embedded Home closed-circuit television by Use of Multiple supersonic Sensors" IEEE Transactions on client physical science, Vol. 56, No. 1, Gregorian calendar month 2010, PP. 119-124
- [4] RufaidaShamroukh, FahedAwad "Detection of living humans in destructed environments employing a simulated autonomous mechanism "IEEE dealing, March 24-26, 2009
- [5] Jean Schultz, Jill L. Drury, Holly A. Yanco "Evaluation of Human-Robot Interaction Awareness in Search and Rescue"IEEE, 2004, PP. 2327-2332
- [6] <http://en.wikipedia.org/wiki/Sensor>

