

Capsulization on Weather Broadcasting System for Rural Area

Prof. Shyam D. Bawankar¹ Kamini Khandarkar² Chanda K. Baghel³

¹Assistant Professor ^{2,3}Student

^{1,2,3}Department of Electronics Engineering

^{1,2,3}DMIETR, Sawangi (Meghe) Wardha, India

Abstract— The fundamental aim is to develop a low cost and robust weather broadcasting system which enables the monitoring of weather parameters in a rural area. Such a system contains of sensors like temperature, humidity, rain forecast, wind speed, also it works on real time date and time will be monitored using Ardino microcontroller board. The data from the sensors are collected by the microcontroller. The microcontroller displays the sensors data into the LED display board in native language and also stored it in the memory card so that we can study the changes in weather over the time. The whole arrangement of this project is based on open source technology such as Ardino Microcontroller Atmega328 Board. Interfacing the LED Display board with microcontroller Atmega328 board and also storing all day data means minimum and maximum temperature, humidity, wind speed, rain forecasting in real time clock.

Key words: Ardino, ATmega328, DHT-11 Sensor, BMP085 Pressure Sensor, Anemometer Sensor, RTC, SD Card, LED Matrix Board

I. INTRODUCTION

The modern tools used to measure temperature, pressure, wind, and humidity in the 21st century would certainly amaze them, and the results obviously are better. Yet, even the most sophisticated numerically calculated forecast made on a supercomputer requires a set of measurements of the condition of the atmosphere—an initial picture of temperature, wind, rain and other basic elements, somewhat comparable to that formed by our forebears when they looked out of their cave dwellings. The primeval approach entailed insights based on the accumulated experience of the perceptive observer, while the modern technique consists of solving equations. Although seemingly quite different, there are underlying similarities between both practices. When people wait under a shelter for a downpour to end, they are making a very-short-range weather forecast. They are assuming, based on past experience, which such hard rain usually does not last very long. In short-term predictions the challenge for the forecaster is to improve on what the layperson can do. Such a system contains pair of sensors like temperature, humidity, rain forecast, wind speed, date and time will be monitored using Ardino Uno microcontroller board. The data from the sensors are collected by the microcontroller. The microcontroller sends the sensors data into the LED display board and also stored it in the memory card so that we can study the changes in weather over the time. The whole arrangement of this project is based on open source technology such as Ardino Microcontroller Atmega328 Board.

Table represents comparison of various microcontroller used in LED display board-

	oller	ry	nt.	current	voltage s
AVR	ATmega328	32Kb	28	40mA	1.8v to 5.5v
AVR	AT89C51	4Kb	40	15mA	6.6v
AVR	AT89C52	8Kb	40	15mA	6.6v
Microch ip	PIC16F877A	8kb	28	25mA	2v to 5.5v

Table 1: Comparison of various microcontrollers

II. PROPOSED SYSTEM

The Proposed System design consists of various sensors are monitoring data and sending to microcontroller. The Proposed block diagram of our system shown in fig.1. One side sensors can send the data consist of various type of sensing unit such as temperature, humidity, pressure sensor, wind direction, wind flow, heat index. The data acquired from sensors is stored in memory card for data logging purpose. Microcontroller for time domain multiplexing i.e. multiplexing the data obtained from different type of sensor as well as for converting the analog data into digital one.

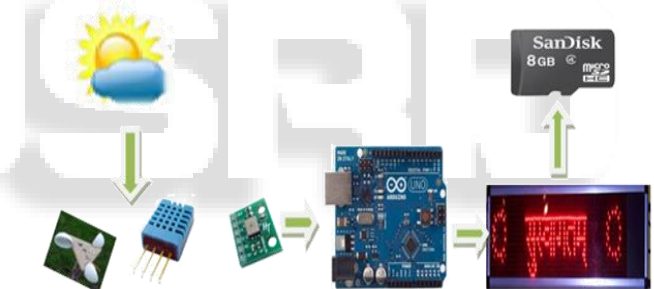

Fig. 1: Proposed System

III. BLOCK DIAGRAM

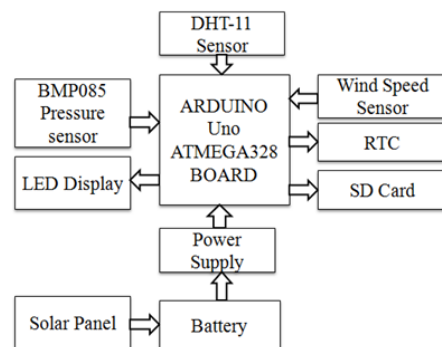

Fig. 2: Block diagram

This is a block diagram of our project the main component is microcontroller of Arduino Uno board (ATmega328). Arduino uno is an open source technology.

The three block are interfacing the microcontroller is LED display. Second is real time clock (RTC) and also SD card. The main sensor of this project is BMP085 barometric pressure sensor. They can give the future information of the rain forecasting. They can detect the next

Trademark	Code of microcontr	Flash memo	Pin cou	Operati ng	Operati ng
-----------	--------------------	------------	---------	------------	------------

day information of rain. Next sensor are used DHT-11(Detecting humidity and temperature) are measured the temperature & humidity also connected with microcontroller and show the L.E.D display. Wind sensor is to measured speed information with the help of motor and also converts the voltage and voltage is measured by speed and this sensor connected with microcontroller. All system existing on solar energy as well as secondary source battery.

A. Problem Definition

No weather monitoring system facilities are available at rural area. Existing systems are very costly to implement in rural area. Also specialist person is requiring for reading parameter. Most of the people are dependent on agriculture. To overcome this drawback we are using this system of rain forecast and also all system will be running on solar energy.

IV. RELATED TO WORK

Weather broadcasting system for rural area is very important part of existing system low cost and also it is useful for all people. So related all those things our system is use Solar Panel.



Fig. 3: Solar Panel System in Rural Area

Today, the technology produces less than one tenth of one percent of global energy. Many people are familiar with so called photovoltaic cells or solar panels, found on things like spacecraft, rooftops and handheld calculators.

V. ADVANTAGES

A. Future Information

The primary advantage of forecasting is that it provides the future information about the weather can use to make decisions about the future of the organization.

B. Save Power:-

In this system power consumption is less because all system is solar panel. Sometime solar panels not charge that time secondary source as battery used.

C. Weather Condition Controlling Purpose:-

Enhanced for monitoring & controlling of atmosphere conditions.

VI. DISADVANTAGES

- It is not possible to accurately forecast the future.
- Tables and chards cannot be used to serve information on the LED display.

VII. CONCLUSION

The proposed design of weather broadcasting is integrated with the help of arduino uno board. The goal is achieved with the help of various sensors and data will be display on LED matrix and also all data stored in real time clock RTC. With the help of this project we can saw the last year information of different parameters and also draw the different types of graph like Minimum temperature Maximum temperature, minimum speed of wind, maximum speed of wind, minimum humidity, maximum humidity, etc.

REFERENCES

- [1] Karthik Krishnamurthi, Suraj Thapa, Lokesh Kothari, Arun Prakash, "Arduino Based Weather Monitoring System".(IJERGS) International Journal of Engineering Research And General Science, March-April, 2015.
- [2] P. Susmith, G. Sowmyabala, "Design And Implementation of Weather Monitoring and Controlling System".(IJCSIT) International Journal of Computer Science and Information Technologies, July, 2014.
- [3] Dev Gaurav, Dishant mittal, Bhavya Vaidya, Jimmy Mathew, "A GSM Based Low Cost Weather Monitoring System for Solar and Wind Energy Generation". VIT University Vellore, India, 2011.
- [4] Prof. S. S. Patil, Prof. V. M. Davande, Prof. J. J. Mulani, "Smart Wireless Sensor Network for Monitoring an Agricultural Environment". (IJCSIT) International Journal of computer Science and Information Technologies Vol. 5 (3), 2014.
- [5] N. MANJULA1, VINUSHA MANDAVA, " Low Cost Weather Monitoring System for Solar Energy Generations using WSN Technolog". (IJSETR) International Journal of Scientific Engineering and Technology Research Volume.04, IssueNo.31, August-2015.
- [6] Dinesh Kulkarni, Sohail Shaikh, Amol Shirasath, Tejaswini Kadam,"Traffic and Weather Monitoring System Using Wireless Sensor Networks". (IJARCCE) International Journal of Advanced Research in Computer and Communication Engineering Vol. 4, Issue 3, March 2015.
- [7] Varsha Dange, Girish Dawkhar, Ishwar Ethape, Pratiksha Jadhav, Gauri Kate, "Weather Monitoring GPS". (IJARCSSE) International Journal of Advanced Research in Computer Science and Software Engineering Volume.5, Issue 3, March – 2015.
- [8] Iswanto, Helman Muhammad, "Weather Monitoring Station with Remote Radio Frequency Wireless Communication". International Journal of Embedded Systems and Applications (IJESA) Vol.2, No.3, September 2012.