

# A Preliminary Work on Non Invasive Technique for Measurement of Hemoglobin

Saravana Kumar T.<sup>1</sup> Prof. Jeeva J.B.<sup>2</sup>

<sup>1</sup>Student <sup>2</sup>Professor

<sup>1,2</sup>Department of Biomedical Engineering

<sup>1,2</sup>School of Bio Science and Technology (SBST), VIT University, Vellore, India

**Abstract**— Hemoglobin (Hb) is the most important vital parameter of red blood cells. Its level in human body is a vital analytic parameter for diagnosing anemia in both long-term and severe conditions. At present, invasive techniques are employed to quantify the Hemoglobin absorption, by which blood is sampled out from the patient and followed by laboratory analysis. Besides from the irritation of taking blood samples, an additional disadvantage of this technique is the time delay between the collection of blood samples and its analysis, which is not suitable for real time patient monitoring under severe condition and rural area with inadequate testing facility. This paper presents an optical non-contact technique that provides Hb concentration measurement. The absorbent coefficient of blood differs at different wavelength this certainty is used to determine the optical property of blood. In this newly developed system, absorption of light by oxygenated and deoxygenated hemoglobin is measured at two wavelength 660nm and 940nm. The particular wavelength of light is obtained from red and IR LED. Constant current circuit is designed to drive the LEDs. Transmitted light through an area of skin on finger was detected by a photodiode. Ratio of Red LED to IR signal after normalization is calculated for determination of Hemoglobin. Signal acquisition by this technique is totally noninvasive.

**Key words:** Hemoglobin, Noninvasive, Red and IR LED, Absorbent coefficient, Transmittance

## I. INTRODUCTION

Measurement of Hemoglobin concentration in blood is a desired parameter to determine the sense of Physiological parameter. In this approach, it is real principle to measure the oxygen level and hemoglobin (Hb) concentration. Hemoglobin (Hb) absorption, low hemoglobin (Hb) level, high hemoglobin level can be observed [1]. Hemoglobin observed in red blood cells (RBC), convey oxygen from the lungs to the other parts of the body for use in oxidative metabolism i.e., reaction with use of oxygen. Anemia during pregnancy is associated with increased risk of still birth, preterm delivery, low birth weight, especially in the case of hemorrhage.

At present the invasive approach is used to measure the hemoglobin concentration [1]. The main disadvantage of the approach is that there is a normal interrupt between the blood accumulation and its analysis. The absorption of hemoglobin concentration of blood in the red LED and infrared LED, the hemoglobin concentration derived and the blood plasma which are mainly composed of water [2]. The noninvasive method of hemoglobin concentration is generally based on the radiation of visible light (red LED) and infrared LED in the range of 660nm and 940 nm. Transmitted light through an area of skin on finger was detected by a photodiode [3].

## II. HEMOGLOBIN CALCULATION METHOD

The oxygen saturation property of blood is used to find the pulse rate and the oxygen saturation of hemoglobin. This oxygen saturation of hemoglobin is a way of estimating the quantity of oxygen that combines to every hemoglobin molecule during each breath. When a light is illuminated, the absorption of light by the hemoglobin molecule takes place. This absorption property of light, changes with the oxygen saturation ability of the blood [2]. The utmost oxygen that can chemically bind within a hemoglobin molecule in the RBCs is equal to the total oxygen present in the blood. Oxygen saturation is denoted as  $SaO_2$  or  $SpO_2$ , and it is the ratio of oxy-hemoglobin ( $HbO_2$ ) to the total concentration of hemoglobin present in the blood [4].

$$I = I_0 e^{-\lambda cd} \quad (1)$$

The Beer-Lambert law says that the amount of light absorbed is equivalent to absorbing medium and the substance, where  $I_0$  is the incident light,  $I$  is the transmitted light,  $\lambda$  is the extinction coefficient of the absorbing substance at a specific wavelength,  $c$  the concentration of the absorbing medium and substance and  $d$  the distance travelled by the light through the medium (1). Normally oximetry will find the oxygen concentration in the arteries i.e.,  $SaO_2$ . The variance in spectrum of absorption of  $HbO_2$  and Hb is employed in the measurement of oxygen concentration in the arteries and the wavelength range that should be used is between 600nm and 1000nm and this is the range where we get least influence from body tissues [5]. Fig. 1. absorption coefficient for Red and IR light.

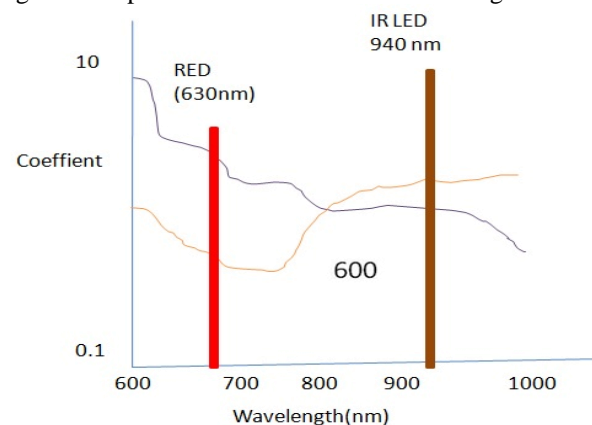

Fig.1: Absorption of Hb and  $HbO_2$

Proper shielding of the LED and photodiode will reduce unwanted light that are scattered from the skin surface plus direct illumination from the LED to the photodiode also should be avoided. By this way, the proportion of the LEDs intensity change across the tissue is determined and this can be then correlated for the determination of oxygen saturation of the blood and the heart pulse in a continuous non-invasive fashion [5].

An optical method for direct measurement of noninvasive hemoglobin was reported by Jeon et al. This design uses an optical system that has two light wavelengths for the determining Hb concentration. This non-invasive hemoglobin determination method is based on Red LED and IR LED. The photo detector detects the light transmitted through the finger [2].

### III. SYSTEM OVERVIEW

Block diagram of noninvasive Hb measurement is shown in the figure [3]. The arteries contain more blood during the contraction of the heart than during the relaxation phase. This is due to the greater diameter of the arteries during the systolic phase. This phenomenon happens only in arteries but not in veins. This cause results in measuring varies characteristics of the blood. The non-invasive sensor allows a continuous determination of the hemoglobin concentration, which is derived from a pulse photometric measurement method. For this purpose an area of skin on the fingertip is illuminated by light source which is emitted by 2 LEDs in the range from 600nm -1000nm. The usage of optical devices is to an implement a non-invasive and continuous measurement of hemoglobin content from the blood. The arteries carry more blood during the contraction of the heart than during the relaxation phase, and this result in an increased artery diameter. This is seen only in arteries and not in veins [6]. For this reason the light absorbing capacity of the tissues in the artery increases during the contraction of the heart and this is due to the fact that increased diameter means more blood which is nothing but more absorbance. Absorbance is varied because of increased optical path. Finally the transmitted light which is influenced by the blood components is collected by using a photo diode. Fig. 2. Block diagram of hemoglobin measurement.

falling on the photodiode produces a small current and this then converted to a voltage of usable level by an amplifier. For this conversation, a resistor-feedback trans-impedance configuration (I/V) is used. This configuration gives a sensitive output even for small change in incident light. This voltage then goes through filtering method and required mathematical conversion is done before values are shown on the LCD of the instrument. Maintaining speedy, genuine, valid measurement on a battery-run device is inspirational. Scattering background is proper masked for elimination of error. A clinical testing is also necessary for improving the determination capability by this method. The main idea behind this measurement of hemoglobin concentration is the fact that variance in absorption/transmission of light through the body tissue [7].

### IV. MEASUREMENT METHOD

The main principle of measurement is the fact that there is a perceptible quantity of absorption or transmission variance when red and near infrared part is used between HbO<sub>2</sub> and Hb. If the level of Hemoglobin concentration of blood decreases, the concentration of the blood plasma raises up. And this leads to the resulting different absorption due to more plasma. Two LEDs red and infra red are used to produce a wavelength of 630nm and 940nm. Concerning accurate calculation of hemoglobin concentration, these wavelengths are chosen. The isosbestic point for spectral absorbance for oxyhemoglobin and de-oxyhemoglobin is at the wavelength 810nm and at this wavelength the hemoglobin is independent of O<sub>2</sub>.

#### A. Circuit Description:

The PIC16F877A is a general purpose 8 bit microcontroller, which offers high performance and very low power consumption. The PIC16F877A contains 256 bytes of EPROM memory, 8channels ADC each with 10-bit. These aspects make PIC16F877A ideal for Analog to Digital application. For the sensing part we use BPW34. BPW34 is a PIN photodiode. It is also a high radiant photodiode. The photodiode is responsive to both visible and near infrared radiation. The peripheral interface controller is mainly used for timing purpose. Fig. 3. shows the circuit diagram for the setup and Fig. 4. shows the preliminary setup.

Fig. 2: Block diagram of hemoglobin measurement  
Photodiodes are used for detection of light and conversion of that into current of appropriate level. The light

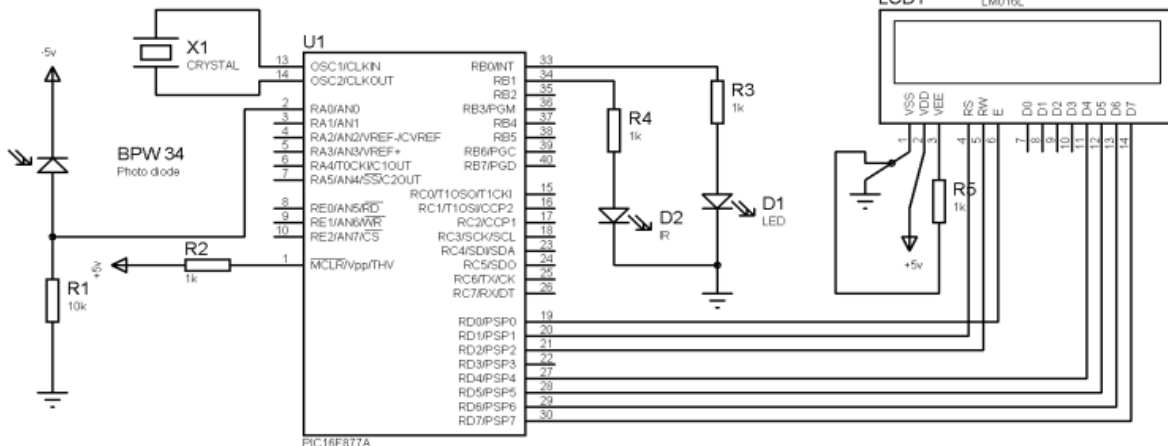
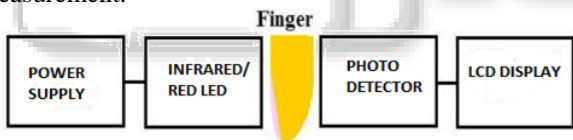

Fig. 3: Circuit Diagram

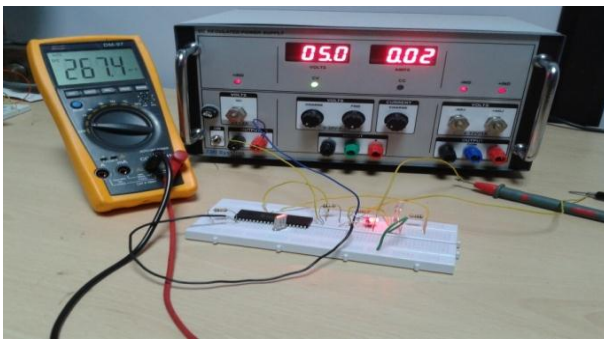

Fig. 4: Preliminary Setup

## V. RESULT AND DISCUSSION

A portable system for measurement of hemoglobin concentration by using wavelength in the range of 660nm and 940nm is developed. Output signal are measured by using multi-meter on various subject, and output voltage is measured in Multi-meter signal are observed by photo detector and output voltage is measured using Multi-meter on various subjects. Fig.5. shows the graphical representation of co-efficient of absorbance

The full radiation of the Red LED and the IR LED at their wavelength gives a voltage as follows:

$$I_0(\text{wavelength})=\text{Red light}=173.4\text{mV}$$

$$I_0(\text{wavelength})=\text{Infrared}=1.1\text{mV}$$

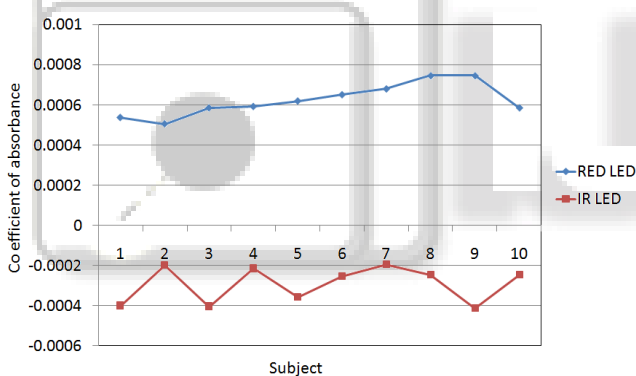

Fig. 5: Graphical representation of Co-efficient of Absorbance

## VI. CONCLUSION

A non-invasive hemoglobin measurement is developed. With the help of developed technique it is possible to observe hemoglobin with two range 660 nm (red LED) and 940nm (IR LED).

## REFERENCES

- [1] J G Webster. Design of Pulse Oximeters. Taylor & Francis, 1997
- [2] U. Timm, E. Lewis, D.McGrath, J.Kraitl, H.E.Ewald, "LED Based Sensor System for Non Invasive " IFBME Proceeding Vol. 23, 825-28, 2008
- [3] Rajashree Doshi and Anagha Panditrao " Non – invasive optical sensor for hemoglobin determination" Vol. 3, Issue 2, March -April 2013, pp.559-562

- [4] Petrova, Prough, D.S.; Petrov, Brecht, "Optoacoustic technique for continuous, noninvasive measurement of total hemoglobin concentration: an in vivo study" IEMBS Volume: 1, 2004
- [5] James Hart, Sofia Iddir, Rob Mahar, Naomi Thonakkaraparayil, "P.O. Pro Wireless Reflectance Pulse Oximeter-Design 1" November 2004
- [6] Woods AM, Queen JS, Lawson D, 1992 "Valsalva maneuver in obstetrics: the influence of peripheral circulatory changes on function of the pulse oximeter. Anesth. Analg 73 pp. 765-71
- [7] U.Timm, E.Lewis, D.McGrath, H E Ewald, "Sensor system concept for Non Invasive Blood Diagnosis" Procedia Chemistry 1 (2009) 493–496