

Agriculture Robot Using DHT11 and Soil Moisture Sensor

Vivek R. Sakhare¹ Dr.Nilesh Bodhne² Dr.Saurabh Lawate³

¹Student ^{2,3}Assistant Professor

^{1,2,3}Department of Electrical Engineering

^{1,2,3}Vidarbha Institute of Technology, Nagpur, India

Abstract — An Agri Robot is an autonomous agricultural robot designed to automate farming tasks, improving efficiency and productivity. The robot is equipped with sensors and AI-powered vision to navigate and perform tasks like planting, watering, and harvesting. With its modular design and adaptability, the Agri Robot can be customized for various crops and farm sizes, addressing labor shortages and promoting sustainable agriculture.

Keywords: Agricultural Robotics; Autonomous Farming System; AI-Powered Vision; Smart Agriculture; Precision Farming; Sustainable Agriculture Technology;

I. INTRODUCTION

Agriculture is the backbone of India's economy, employing over 50% of the workforce. However, the sector faces significant challenges, including labor shortages, increasing costs, and climate change. To address these issues, we introduce the Agri Robot, an autonomous agricultural robot designed to revolutionize farming practices.

The Agri Robot is a cutting-edge, AI-powered solution that automates tasks like planting, watering, and harvesting, improving efficiency, productivity, and crop yields. With its advanced sensors and machine learning capabilities, the robot navigates and adapts to changing farm conditions, reducing waste and promoting sustainable agriculture.

By leveraging technology, the Agri Robot aims to transform Indian agriculture, enhancing farmers' livelihoods and contributing to the country's food security.

II. METHODOLOGY:

The Arduino Uno is a popularly used open-source microcontroller board that runs on ATmega 328P micro-controller. This board is developed by Arduino.cc which is an Italy based hardware company. This board contains a set of digital and analog I/O data pins that are used to interface this board with other electronic components.

Arduino Uno consists of 14 digital pins and 6 analog pins. This board can be programmed with the help of Arduino IDE (Integrated Development Environment) that supports embedded C, its back-end is constructed using JAVA. Uno consists of an USB port through which the code can be uploaded on to the board. This port can also be used to power the board by connecting it to a laptop, PC, etc. Along with a USB port, it also has a DC input power jack. An external battery of 9V can also be used to power Arduino board point and the receiver circuit will convert their voice signal in simple language and will show output in the speaker.

– The whole transmitter system will work on 9voltdc battery.

This communication system works on free wireless radio signals technology that are working on radio signals tower of government and the both the circuits can easily

connect and the communication process can be easily shown free of cost.

III. HARDWARE REQUIRED

A. Arduino UNO

Arduino Uno is an open-source microcontroller board based on the processor ATmega328P. There are 14 digital I/O pins, 6 analog inputs, a USB connection, a power jack, an ICSP header, and a reset button. It contains all the necessary modules needed to support the microcontroller. Just plug it into a computer with a USB cable or power it with an adapter to get started. You can experiment with your Arduino without worrying too much about it. In the event of a worst-case scenario, you could buy a new one as the Uno is very economical compared to other boards like raspberry pi, STM, etc.

- Microcontroller: Microcontroller is the central processing unit of Arduino Uno.
- Digital Pins: There are 14 digital pins on Arduino Uno which can be connected to components like LED, LCD, etc.
- Analog Pins: There are 6 analog pins on the Uno. These pins are generally used to connect sensors because all the sensors generally have analog values. Most of the input components are connected here.
- Power Supply: The power supply pins are IOREF, GND, 3.3V, 5V, Vin are used to connecting sensors because all the sensors generally have analog values. Most of the input components are connected here.
- Power Jack: Uno board can be powered both by external supply and via USB cable.
- USB Port: This port function is to program the board or to upload the program. The program can be uploaded to the board with the help of Arduino IDE and USB cable.
- Reset Button: This is used to restart the uploaded program.



B. DHT11 Sensor

The DHT11 is a basic, low-cost digital temperature and humidity sensor.

- DHT11 is a single wire digital humidity and temperature sensor, which provides humidity and temperature values serially with one-wire protocol.
- DHT11 sensor provides relative humidity value in percentage (20 to 90% RH) and temperature values in degree Celsius (0 to 50 °C).

DHT11 sensor uses resistive humidity measurement component, and NTC temperature measurement component.

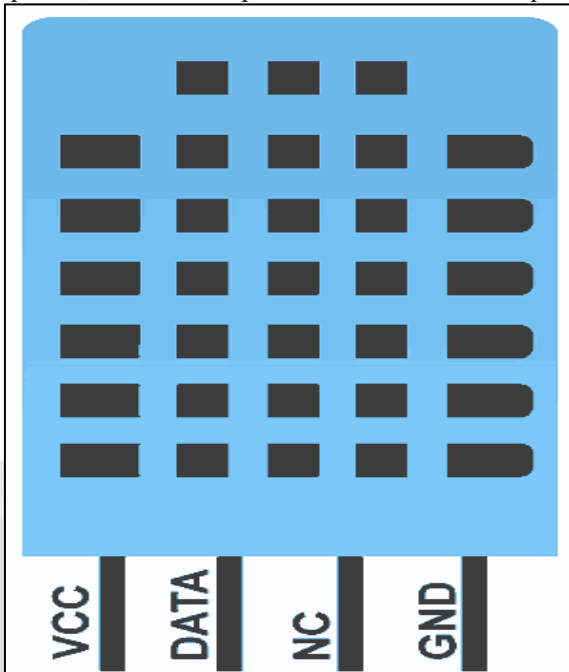

C. Soil Moisture Sensor

The moisture of the soil plays an essential role in the irrigation field as well as in gardens for plants. As nutrients in the soil provide the food to the plants for their growth. Supplying water to the plants is also essential to change the temperature of the plants. The temperature of the plant can be changed with water using the method like transpiration. And plant root systems are also developed better when rising within moist soil. Extreme soil moisture levels can guide to anaerobic situations that can encourage the plant's growth as well as soil pathogens. This article discusses an overview of the soil moisture sensor, working and its applications.

moisture sensor is one kind of sensor used to gauge the volumetric content of water within the soil. As the straight gravimetric dimension of soil moisture needs eliminating, drying, as well as sample weighting. These sensors measure the volumetric water content not directly with the help of some other rules of soil like dielectric constant, electrical resistance, otherwise interaction with neutrons, and replacement of the moisture content.

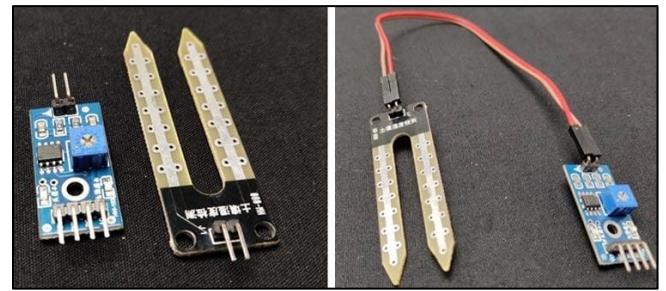

D. Relay

A relay module is an electrically operated switch that allows low- power control signals (like those from an Arduino or Raspberry Pi) to safely control high-power devices, such as motors, lights, and appliances. It provides complete electrical isolation between the fragile microcontroller and the high-voltage load.

How It Works

- Control Side (Low Power): Typically runs on 5V or 3.3V. The microcontroller sends a signal to a transistor or optocoupler, which energizes an electromagnet inside the relay.
- Load Side (High Power): Features terminals labeled COM (Common), NO (Normally Open), and NC (Normally Closed). When triggered, the switch connects COM to NO, completing the high-voltage.

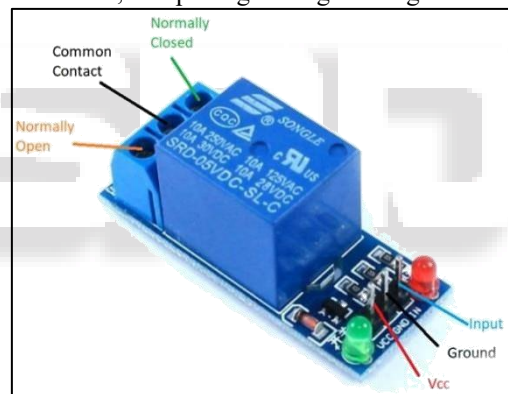

E. DPDT Switch

A DPDT switch (double-pole, double-throw) is an electromechanical switch that can be formed by adding a pole to the SPDT switch. This is very easy to install because it is available with a locking system that can lock & unlock the switch directly in a remote cabinet without using any Nut-Bolts or screw for fitting. This article discusses an overview of a DPDT switch and its working with applications.

IV. BLOCK DIAGRAM

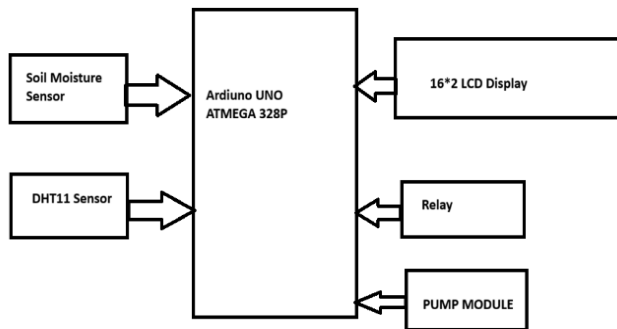

A. Working:

Working of this project is in manual mode, agriculture Horticulture and gardening area the manual mode of operation in land rotate in forward direction backward direction left direction and right direction. We have used four motors for are generally this robot and connect with DPDT switch operate all four manual codes in this project. We have also used soil sensor and dht11 sensor show the value of temperature and humidity in the land, this soil sensor is used for control the motor for pesticides spraying.

The Agri Robot uses a DHT11 temperature and humidity sensor and a soil moisture sensor to monitor and control farm conditions. Here's how it works:

- 1) **Soil Moisture Monitoring:** The soil moisture sensor detects the moisture level in the soil and sends data to the Arduino UNO.
- 2) **Temperature and Humidity Monitoring:** The DHT11 sensor measures temperature and humidity, sending data to the Arduino UNO.
- 3) **Data Analysis:** The Arduino UNO analyzes the data and determines if the soil needs watering or other actions.
- 4) **Action:** If the soil is dry, the robot triggers the water pump to irrigate the crops.

Alerts: The robot sends alerts to the farmer's mobile if conditions are extreme (e.g., high temperature, low moisture). Agrirobot system. We used the microcontroller Arduino UNO board to interface with different components required in our project.

All components are to be properly interfaced with the board then the circuit can be operated as we want. We have to also design the proper mechanism for pesticides spray

V. SOFTWARE ARCHITECTURE

A. Arduino IDE

Arduino is open-source platform for all and using this software we are use Agri robot.in this Agri robot we are used embedded c language. Arduino IDE (Integrated Development Environment) is a software platform that enables a user to program Arduino or any controller of the ATmega family. The back-end of this software is developed using JAVA. This IDE provides a user the liberty to program an Arduino using C language. It connects to the Arduino and hardware to upload programs and communicate with them. The IDE consists of two main parts viz.

- void setup (): This is the location where a user can initialize all the variables that will be required during the

course of programming a system. As the name suggests, this function is used to set up an Arduino before interfacing it with other circuits. This area can also be used to include libraries of various sensors. The popularly used functions in void setup are:

- pinMode: This function is used to declare pins of Arduino as input or output.
- serial.begin: This function is used when Arduino is communicating with other sensors or devices. This enables a user to set a specific baud rate for communication purpose.
- void loop (): The code written in this space will run over and over again unless Arduino is interrupted using an interrupt or the USB cable is disconnected from the USB port. The different functions that are often used in void loop are:
 - digitalWrite: This function is used to make a specific pin on Arduino logically HIGH or LOW.
 - digitalRead: This function is used when there is a need to read digital data from a sensor or when we have to control something using a switch/ push button.
 - AnalogRead: This function comes in handy when we have to read analog data from a sensor e.g. Analog read is used when there is a need to read data from a potentiometer.
 - AnalogWrite: This function is used when a user wants to supply analog voltages to a component. The best example of analog write is when the intensity of LED is controlled using a potentiometer and analog write function.

B. Arduino IDE

You can download the Software from Arduino main website. As I said earlier, the software is available for common operating systems like Linux, Windows, and MAX, so make sure you are downloading the correct software version that is easily compatible with your operating system.

If you aim to download the Windows app version, make sure you have Windows 8.1 or Windows 10, as the app version is not compatible with Windows 7 or older version of this operating system.

- Tools - Mainly used for testing projects. The Programmer section in this panel is used for burning a bootloader to the new microcontroller.
- Help - In case you are feeling skeptical about software, complete help is available from getting started to troubleshooting
- The Six Buttons appearing under the Menu tab are connected with the running program as follows.
- The checkmark appearing in the circular button is used to verify the code. Click this once you have written your code.

You can download the latest version of Arduino IDE for Windows (Non-Admin standalone version), by clicking below button:

The IDE environment is mainly distributed into three sections

- Menu Bar
- Text Editor
- Output Pane

As you download and open the IDE software, it will appear like an image below:

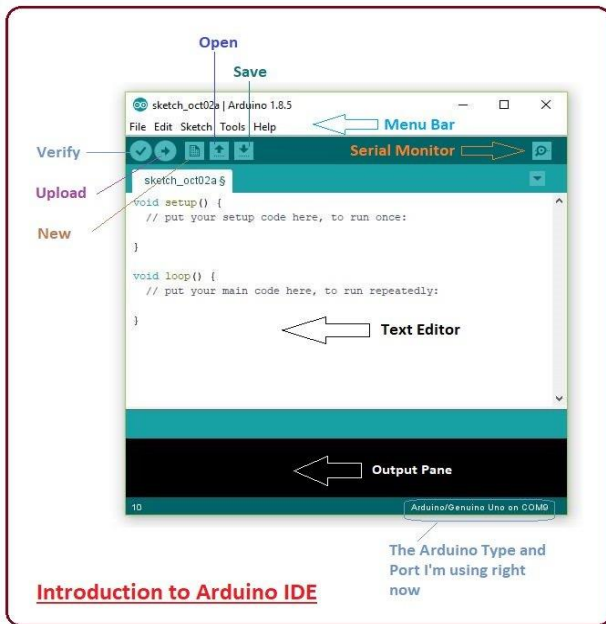

The bar appearing on the top is called Menu Bar that comes with five different options as follow

- File - You can open a new window for writing the code or open an existing one. The following table shows the number of further subdivisions the file option is categorized into.

C. Application

- This can be used for to measure temperature and humidity of seed and environment.
- They can also be used for Performing seed and digging.
- It can be used for agriculture for increase seed growth.

D. Advantages

- They can also be used for agriculture, gardening and public places.
- This can be used for to measure temperature and humidity of crop, flower.
- A soil moisture sensor using relay module motor will be automatic on or off if water is necessary this place.

VI. FUTURE SCOPE

For further development of this project, we can be GSM and GPS modules. In GSM module, the value of temperature and humidity will be show in mobile. Using GPS the exact location of crop will be showed and we are protected our seed. We are using WIFI module the real time value of temperature and humidity will be shown using the application. Agri robot in manual mode we are converted to automatic mode then the robot automatic rotated in farm and exact values in our application.

VII. CONCLUSION

- This Automatic seed sowing & irrigation Agrirobot has increase productivity for INDIAN farmer.
- The chassis handles the complete weight of solar panel, battery and the hardware mounted on agrirobot which is

able to perform each and every operation skillfully and successfully.

- The irrigation process is done better than before to yield the proper production done before and usage of water level is limited and increase the production rate.

REFERENCES

- [1] Design development of an a autonomous Agri robot by IEEE Xplore.
- [2] Agricultural robots a review by journal of agricultural science and technology.
- [3] Agriculture robotics by springer.
- [4] Robotics in agriculture by CRC press.
- [5] Agriculture robotics by robotics business review.
- [6] Sridhar H.S "Development of Single Wheel Multi-Use Mutually Operated Weed Remover", International Journal of Modern Engineering Research, 2013, Vol. 3, Issue.6, Pp-3836-3840