

Smart Helmet with Accident Detection

Rohan Dinkar Suryawanshi¹ Suraj Gopichand Sudit² Aayush Sachine Gaikwad³
Aditya Raju Kamble⁴

^{1,2,3,4}Department of Electronics and Telecommunication Engineering
^{1,2,3,4}Jayawantrao Sawant Polytechnic, Pune, India

Abstract — Road accidents involving motorcyclists are one of the major causes of injuries and fatalities worldwide. Many accidents become more serious due to the absence of proper safety measures and delayed emergency response. This paper presents the design and development of an IoT-based Smart Helmet Safety System that improves rider safety by integrating multiple sensors and real-time communication technology. The proposed system is built around an ESP32 microcontroller integrated with several sensors such as MQ3 for alcohol detection, MQ2 for gas detection, MPU6050 for accident detection, DHT22 and BME280 for environmental monitoring, and MLX90614 for body temperature measurement. The system ensures that the motorcycle starts only when the rider wears the helmet, thereby enforcing helmet usage and improving road safety. In the event of sudden impact or abnormal motion detected by the MPU6050 sensor, the system identifies a potential accident. Once an accident is detected, the ESP32 automatically sends an emergency alert message to predefined contacts through a Telegram Bot using Wi-Fi connectivity. The system is powered by lithium batteries supported by a solar panel, providing a sustainable and efficient power source. By combining rider authentication, accident detection, environmental monitoring, and real-time alert communication, the proposed system aims to reduce accident risks and improve emergency response time.

Keywords: Smart Helmet Safety System; Internet of Things (IoT); ESP32 Microcontroller; Accident Detection System; Alcohol Detection Sensor; Real-Time Emergency Alert

I. INTRODUCTION

Motorcycle accidents are one of the major causes of injuries and fatalities on roads. Riders are more vulnerable to accidents due to the lack of physical protection compared to other vehicle users.

Although helmets are designed to reduce head injuries, many riders fail to wear them properly. In addition, delayed communication during accidents often increases the severity of injuries. Therefore, an intelligent safety system is required to improve rider protection and provide quick emergency alerts.

This paper presents an IoT-based Smart Helmet Safety System designed to enhance motorcycle rider safety. The system uses an ESP32 microcontroller integrated with multiple sensors such as MPU6050 for accident detection, MQ3 for alcohol detection, MQ2 for gas detection, DHT22 and BME280 for environmental monitoring, and MLX90614 for body temperature measurement. The system also ensures that the motorcycle starts only when the rider wears the helmet.

In case of an accident detected by the sensors, the ESP32 sends an emergency alert message through a Telegram Bot to predefined contacts using Wi-Fi connectivity. The system is powered by lithium batteries supported by a solar

panel, making it efficient and reliable. The proposed smart helmet aims to improve rider safety and reduce accident response time.

II. SYSTEM OVERVIEW

The proposed Smart Helmet Safety System is designed to enhance motorcycle rider safety by integrating multiple sensors and IoT-based communication. The system is built around an ESP32 microcontroller, which acts as the central processing unit and manages all sensor inputs and communication functions.

The helmet is equipped with several sensors to monitor different safety parameters. The MPU6050 accelerometer and gyroscope sensor is used to detect sudden motion, abnormal tilt, or impact that may indicate an accident. The MQ3 sensor is used for alcohol detection to ensure that the rider is not under the influence of alcohol, while the MQ2 sensor detects smoke or harmful gases in the environment. Environmental conditions such as temperature, humidity, and pressure are monitored using DHT22 and BME280 sensors. Additionally, the MLX90614 infrared sensor measures the rider's body temperature without physical contact.

The system also includes a mechanism that allows the motorcycle to start only when the rider is wearing the helmet, thereby enforcing helmet usage. In the event of an accident, the ESP32 processes the sensor data and automatically sends an emergency alert message through a Telegram Bot using Wi-Fi connectivity.

The system is powered by three lithium batteries connected through a battery holder, and voltage regulation is provided using an IC 7805 voltage regulator with a heat sink to ensure stable operation. A solar panel is integrated as a supplementary power source to extend battery life and improve energy efficiency.

III. METHODOLOGY

The proposed smart helmet system is developed by integrating multiple sensors with an ESP32 microcontroller to monitor rider safety and detect accident conditions. All sensors are connected to the ESP32 through an ESP32 shield, which simplifies circuit connections and improves system reliability.

The MPU6050 sensor continuously monitors the motion and orientation of the helmet. If sudden acceleration, abnormal tilt, or strong impact is detected, the system identifies a possible accident condition. The MQ3 sensor detects alcohol vapors to determine whether the rider is under the influence of alcohol, while the MQ2 sensor detects smoke or harmful gases in the surrounding environment.

Environmental parameters such as temperature, humidity, and atmospheric pressure are measured using the DHT22 and BME280 sensors. The MLX90614 infrared

sensor measures the rider's body temperature without direct contact.

All sensor data is processed by the ESP32 microcontroller. If an accident is detected, the ESP32 connects to the internet using its built-in Wi-Fi module and

sends an emergency alert message through a Telegram Bot to predefined contacts. The system is powered by lithium batteries supported by a solar panel to provide continuous and efficient operation.

IV. BLOCK DIAGRAM AND EXPLANATION

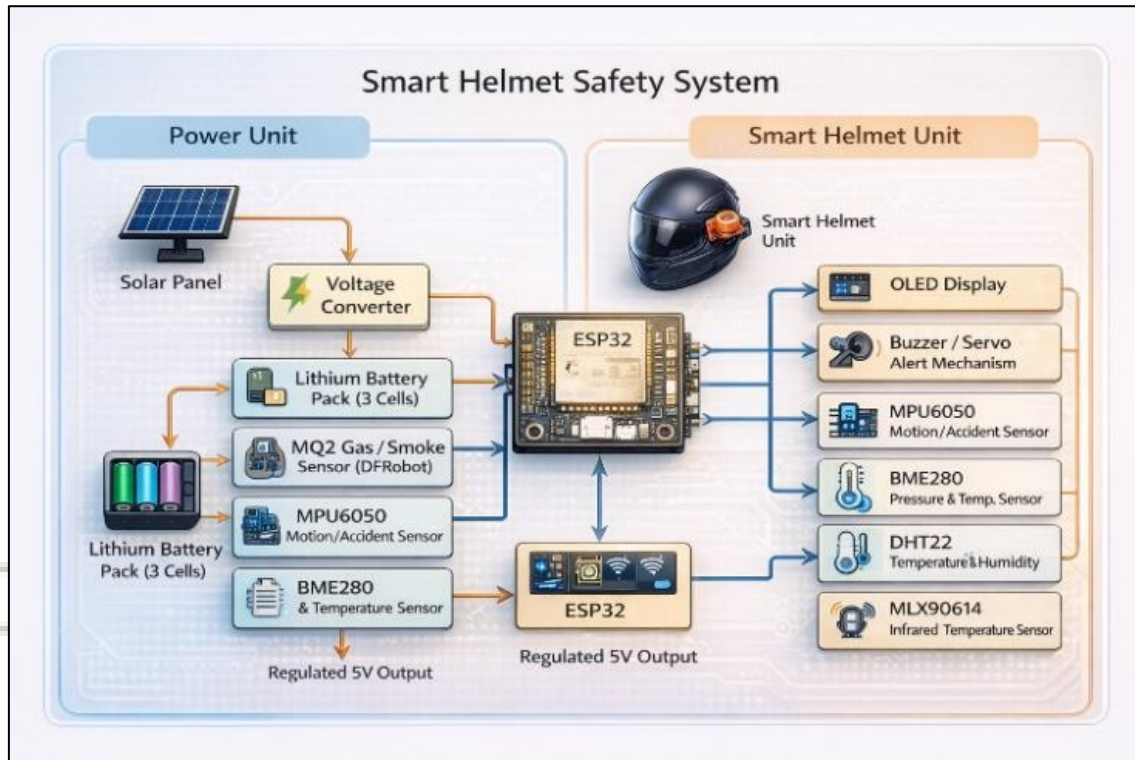

The diagram represents an IoT-based Smart Helmet Safety System that integrates multiple sensors with an ESP32 microcontroller to monitor rider safety and send emergency alerts. The ESP32 with shield acts as the central control unit of the system. All sensors and power modules are connected to the ESP32, which collects sensor data, processes it, and sends alerts through Wi-Fi using a Telegram Bot when abnormal conditions are detected.

- 1) ESP32 Microcontroller (Main Controller)
The ESP32 is the core component of the system. It reads data from all connected sensors, processes the sensor signals, detects accident or unsafe conditions, and sends emergency alerts through Wi-Fi. The ESP32 shield simplifies the connection of sensors and power supply.
- 2) MPU6050 Sensor (Accident Detection)
The MPU6050 is an accelerometer and gyroscope sensor used to detect sudden impact, abnormal tilt, and rapid motion changes. If these values exceed a predefined threshold, the system identifies a possible accident.
- 3) MQ3AlcoholSensor: The MQ3 sensor detects alcohol vapors in the rider's breath. It helps prevent the rider from starting the bike if alcohol is detected and improves road safety by discouraging drunk driving.
- 4) MQ2GasSensor (DFRobot): The MQ2 sensor detects harmful gases or smoke such as LPG, methane, and smoke. This helps in monitoring environmental safety conditions
- 5) MLX90614 Temperature Sensor
The MLX90614 infrared sensor measures the body

temperature of the rider without physical contact. This sensor can be used for health monitoring and detecting abnormal body temperature.

- 6) DHT22 Sensor: The DHT22 sensor measures temperature and humidity. These environmental parameters help monitor the surrounding conditions.
- 7) BME280 Sensor: The BME280 sensor measures temperature, humidity, and atmospheric pressure. It provides additional environmental data for better monitoring.
- 8) Lithium Battery Pack: The system uses three lithium-ion cells (18650 batteries) placed in a lithium battery holder. These batteries supply power to the entire system and provide portable operation.
- 9) IC 7805 Voltage Regulator with Heat Sink
The IC 7805 regulator converts battery voltage to a stable 5V supply required by the sensors and ESP32. The heat sink prevents overheating of the regulator during operation.
- 10) Solar Panel: The solar panel acts as a renewable power source. It charges the lithium batteries, increases battery life, and reduces dependency on external charging.
- 11) Communication (Telegram Alert)
When an accident is detected, sensor data is processed by the ESP32. The ESP32 then connects to the internet using Wi-Fi and sends a message through a Telegram Bot. The alert is received by family members or emergency contacts, ensuring quick emergency response.

V. CIRCUIT DIAGRAM

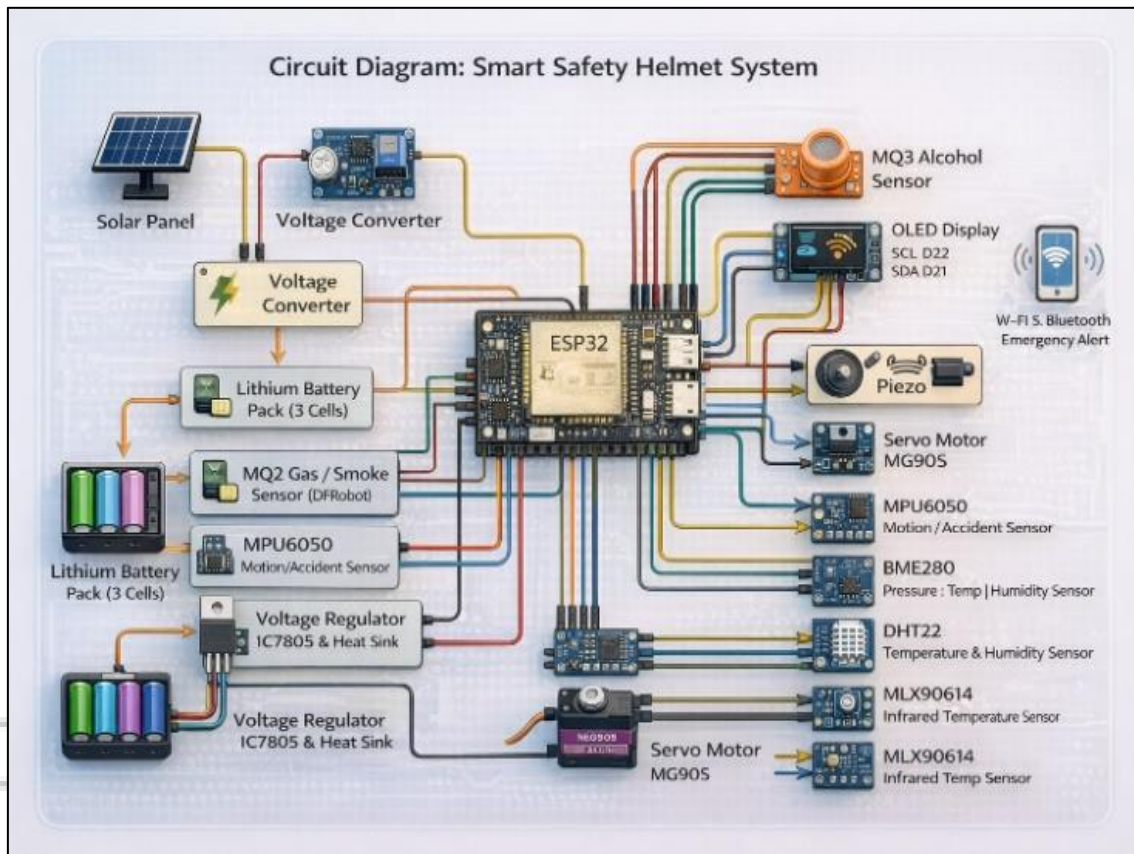

The circuit diagram illustrates the hardware implementation of the proposed Smart Helmet Safety System. The system is designed using an ESP32 microcontroller that acts as the central control unit and interfaces with multiple sensors and modules to monitor rider safety and environmental conditions.

The power supply for the system is provided by a lithium battery pack consisting of three lithium-ion cells. A solar panel is integrated to recharge the batteries, improving the energy efficiency of the system. The output voltage from the battery is regulated using an IC7805 voltage regulator with a heat sink to maintain a stable 5V supply required for the ESP32 and other electronic components.

The ESP32 microcontroller is connected to several sensors that monitor different safety parameters. The MQ3 sensor is used for detecting alcohol vapors in the rider's breath, helping prevent drunk driving. The MQ2 gas sensor detects harmful gases such as smoke or LPG in the surrounding environment. The MPU6050 sensor, which contains an accelerometer and gyroscope, is used for motion monitoring and accident detection by identifying sudden impacts or abnormal tilt.

Environmental conditions are monitored using the BME280 and DHT22 sensors, which measure parameters such as temperature, humidity, and atmospheric pressure. Additionally, the MLX90614 infrared temperature sensor is used to measure the body temperature of the rider without physical contact.

The ESP32 processes the data collected from these sensors and displays important information on an OLED display. In case of dangerous situations such as alcohol

detection, gas leakage, or accident occurrence, the system activates an alert mechanism and sends emergency notifications using the wireless communication capability of the ESP32. This alert can be transmitted through internet-based platforms such as Telegram to notify family members or emergency contacts.

Thus, the circuit integrates sensing, processing, power management, and communication modules to develop an efficient IoT-based smart helmet safety system.

VI. ADVANTAGES

- 1) **Improves Rider Safety:** The system enhances rider safety by continuously monitoring different conditions using multiple sensors such as MPU6050, MQ3, and MQ2. In case of an accident or abnormal situation, the system can immediately detect the event and trigger an alert.
- 2) **Real-Time Accident Detection:** The MPU6050 accelerometer and gyroscope sensor detects sudden impacts, abnormal tilt, or strong vibrations. This enables quick identification of road accidents and allows emergency alerts to be sent to concerned contacts.
- 3) **Alcohol and Gas Monitoring:** The MQ3 alcohol sensor detects alcohol presence in the rider's breath, helping prevent drunk driving. Additionally, the MQ2 gas sensor can detect harmful gases or smoke, improving safety in hazardous environments.
- 4) **Environmental and Health Monitoring:** Sensors such as DHT22, BME280, and MLX90614 monitor temperature, humidity, atmospheric pressure, and body temperature.

This helps in observing environmental conditions and the rider's physical status.

- 5) **Renewable Power Support:** The integration of a solar panel allows the system to utilize renewable energy for charging the lithium battery pack. This improves energy efficiency and reduces the need for frequent external charging.
- 6) **Wireless Communication and Instant Alerts**
The ESP32 microcontroller provides built-in Wi-Fi connectivity, enabling the system to send real-time notifications through platforms like Telegram. This ensures quick communication with family members or emergency services.
- 7) **Compact and Smart IoT-Based Design**
The use of lightweight sensors and an ESP32 microcontroller enables the development of a compact and intelligent IoT-based smart helmet system suitable for real-world applications.

VII. LIMITATIONS

- 1) **Dependence on Internet Connectivity:** The system relies on Wi-Fi connectivity provided by the ESP32 to send emergency alerts through Telegram. In areas with weak or no internet connection, alert messages may be delayed or may not be delivered.
- 2) **Sensor Sensitivity and Environmental Influence:** Sensors such as MQ2 and MQ3 may sometimes produce inaccurate readings due to external environmental conditions like smoke, humidity, or temperature variations. Proper calibration is required to maintain accuracy.
- 3) **Limited Battery Capacity:** Although the system uses lithium batteries and a solar panel for charging, the battery capacity may still limit long-term operation if solar charging is insufficient or the system consumes more power.
- 4) **Possibility of False Accident Detection:** The MPU6050 sensor detects sudden movement or vibration. In some cases, dropping the helmet or sudden jerks may trigger false accident alerts.
- 5) **Hardware Integration Complexity:** Integrating multiple sensors, power modules, and communication components within a helmet structure can increase the complexity of the design and installation process.
- 6) **Maintenance and Calibration Requirement:** Sensors and electronic components may require periodic maintenance and recalibration to ensure accurate performance and long-term reliability.

VIII. HARDWARE COMPONENTS LIST

- 1) **ESP32 Microcontroller**
 - Acts as the main processing unit of the system.
 - Collects and processes data from all connected sensors and sends emergency alerts through Wi-Fi.
- 2) **ESP32 Shield**
 - Provides a convenient interface for connecting sensors and other electronic components.
 - Simplifies circuit connections and improves system stability.
- 3) **MQ3 Alcohol Sensor**

- Detects alcohol vapors from the rider's breath.
 - Helps prevent drunk driving by identifying alcohol consumption.
- 4) **MQ2 Gas Sensor (DF Robot)**
 - Detects harmful gases such as LPG, methane, and smoke.
 - Used for monitoring environmental safety conditions.
 - 5) **MPU6050 Sensor**
 - Contains an accelerometer and gyroscope for motion sensing.
 - Detects sudden impact, abnormal tilt, and movement for accident detection.
 - 6) **DHT22 Sensor**
 - Measures environmental temperature and humidity.
 - Provides important data for monitoring surrounding environmental conditions.
 - 7) **BME280 Sensor**
 - Measures temperature, humidity, and atmospheric pressure.
 - Used for advanced environmental monitoring.
 - 8) **MLX90614 Infrared Temperature Sensor**
 - Measures the body temperature of the rider without physical contact.
 - Useful for health monitoring and detecting abnormal temperature conditions.
 - 9) **Lithium Cells (3 Batteries)**
 - Provide rechargeable power supply to the entire system.
 - Ensure portable and reliable operation of the smart helmet.
 - 10) **Lithium Battery Holder**
 - Holds the lithium batteries securely in place.
 - Provides proper electrical connections for power distribution.
 - 11) **IC 7805 Voltage Regulator**
 - Converts higher battery voltage into a stable 5V supply.
 - Protects electronic components from voltage fluctuations.
 - 12) **Heat Sink**
 - Attached to the voltage regulator to dissipate excess heat.
 - Prevents overheating and improves system reliability.
 - 13) **Solar Panel**
 - Generates electrical energy from sunlight.
 - Used to recharge the lithium batteries and improve energy efficiency.

IX. FUTURE SCOPE

The proposed Smart Helmet Safety System can be further enhanced by integrating additional advanced technologies to improve its functionality and reliability. In the future, a GPS module can be incorporated into the system to provide real-time location tracking during accident situations. This feature would allow emergency services and family members to quickly identify the exact location of the rider and provide immediate assistance.

Another possible improvement is the development of a dedicated mobile application that can communicate with the helmet through the ESP32 microcontroller. Such an application can display real-time sensor data, helmet status, and emergency alerts, providing better monitoring and control for the user.

The system can also be integrated with the motorcycle ignition system so that the vehicle will only start when the helmet is properly worn and no alcohol is detected. This feature would help enforce helmet usage and reduce the risk of drunk driving, thereby improving overall road safety.

In addition, cloud-based data storage and analysis can be implemented to store sensor data for long-term monitoring and research purposes. This would allow analysis of riding patterns, accident conditions, and environmental factors, which could contribute to future road safety improvements.

Furthermore, advanced technologies such as Artificial Intelligence and Machine Learning can be applied to analyze sensor data more accurately. This would help distinguish between normal movements and actual accident situations, reducing false alerts and improving the reliability of the system. With these enhancements, the Smart Helmet Safety System can evolve into a more intelligent and comprehensive safety solution for modern transportation.

X. CONCLUSION

The Smart Safety Helmet system is designed to improve rider safety by integrating various sensors and smart technologies. The system uses sensors such as the MQ3 alcohol sensor, MPU6050 motion sensor, and environmental sensors to monitor the rider's condition and surrounding environment. These sensors work together with the ESP32 microcontroller to detect unsafe situations such as alcohol consumption, accidents, or abnormal environmental conditions.

The integration of multiple sensors helps in providing real-time monitoring and quick response during emergency situations. The use of lithium batteries and a solar panel ensures a reliable and energy-efficient power supply for continuous operation. By combining safety monitoring, environmental sensing, and smart communication capabilities, the system helps reduce the risks faced by motorcycle riders.

Overall, the proposed Smart Safety Helmet system provides an effective and innovative approach to enhancing road safety. With further improvements such as GPS tracking, mobile application integration, and advanced data analysis, the system can become a more powerful tool for preventing accidents and ensuring rider protection in the future.

ACKNOWLEDGMENT

We sincerely thank the Department of Electronics and Telecommunication Engineering at JSPM's Jaywantrao sawant Polytechnic, Pune, for their valuable guidance and support throughout the development of this project. Their expert advice and encouragement were essential in successfully completing the Smart Helmet with Accident Detection

REFERENCES

[1] M. Paul, S. Datta, M. Debnath, R. Das, S. Debbarma, and S. Debbarma, "Smart Helmet Based Accident Detection and Notification," *International Journal of Innovative Research in Electrical, Electronics, Instrumentation and Control Engineering*, 2025.

- [2] S. D. Dhere, S. Aher, R. Agalme, and M. Kachake, "Smart Helmet for Accident Detection and Prevention Using IoT," *International Journal of Science and Research Archive*, vol. 15, no. 1, pp. 1537–1543, 2025.
- [3] N. Srinivasa Gupta, M. Nandini, N. Sowjanya, L. Pardha Sai, and K. Sai, "Smart System for Rider Safety and Accident Detection," *International Journal of Engineering Research & Technology (IJERT)*, vol. 9, no. 6, 2020.
- [4] M. Magdum, S. Somawanshi, A. Khivansara, S. Sawant, and R. Chopade, "Smart Helmet for Safety and Accident Prevention," *International Journal for Research in Applied Science and Engineering Technology (IJRASET)*, 2022.
- [5] H. C. Impana and C. N. Channegowda, "A Review on Smart Helmet for Accident Detection Using IoT," *EAI Endorsed Transactions on Internet of Things*, 2019.
- [6] S. Sharma et al., "Smart Helmet for Accident Detection Using IoT," *International Journal of Engineering Research & Technology (IJERT)*, vol. 9, no. 4, 2021.
- [7] K. Duseja and S. Verulkar, "Smart Helmet for Accident Detection," *International Journal of Computer Science and Network Security*, vol. 8, no. 2, pp. 148–150, 2019.
- [8] F. A. Basit, M. Ahmed, M. Zubair, and S. Ahmed, "Analyzing the Impact of Smart Helmet Usage and Traffic Violations on Motorbike Accident Fatalities," *AITU Scientific Research Journal*, 2024.