

EV Battery Management System and Fire Protection

Prachi Mane¹ Ankita Jamage² Shruti Mane³ Tejaswini Kadam⁴

^{1,2,3,4}Department of Electronics & Telecommunication Engineering

^{1,2,3,4}Jayawantrao Sawant Polytechnic, Hadapsar, Pune, India

Abstract — This project is based on an EV Battery Management System with Fire Protection using GSM. The main aim of this project is to provide safety to the battery used in electric vehicles. The system continuously checks important battery values like voltage and temperature using sensors. If the battery gets overheated or overcharged, the system automatically cuts off the battery supply and turns ON the fire protection unit. At the same time, a GSM module sends an alert message to the user's mobile phone about the problem. This helps in taking quick action and prevents accidents. This project helps to protect the battery from damage, increases battery life, and reduces the chances of fire. It is very useful for electric vehicles and other battery-operated devices.

Keywords: Electric Vehicle, Battery Management System, Fire Protection, GSM Alert, Temperature Sensor, Safety System

I. INTRODUCTION

Electric vehicles (EVs) are becoming popular because they help reduce air pollution and save fuel. The most important part of an EV is its battery, which provides power to run the vehicle. Lithium-ion batteries are commonly used in electric vehicles because they can store more energy and last longer. But these batteries can be dangerous if they are not properly handled or protected.

Sometimes, due to overcharging, overheating, or short circuit, the battery may get damaged and can even catch fire. To avoid these problems, a Battery Management System (BMS) is needed. A BMS is used to monitor and control the battery conditions such as voltage and temperature. It helps in keeping the battery safe and improves its life.

In this project, an EV Battery Management System with Fire Protection using GSM is designed. Sensors are used to check the battery voltage and temperature continuously. If the system detects any abnormal condition like high temperature or overvoltage, it automatically cuts off the battery supply and activates a fire protection unit. At the same time, a GSM module sends an alert message to the user's mobile phone.

A. Objective

- 1) To make a system that protects the EV battery from damage.
- 2) To check the battery voltage and temperature continuously.
- 3) To find out when the battery gets overheated or overcharged.
- 4) To send alert messages to the user using GSM.

B. Concept Overview

The main idea of this project is to keep the EV battery safe from damage and fire. In electric vehicles, the battery can become dangerous if it gets too hot, overcharged, or short-

circuited. So, it is important to monitor the battery condition all the time.

In this system, sensors are used to measure the battery voltage and temperature. These sensors send the data to a microcontroller, which controls the whole system. The microcontroller checks whether the battery values are within safe limits.

If the battery temperature or voltage becomes too high, the system immediately switches OFF the battery supply using a relay. It also turns ON the fire protection unit to stop fire from spreading. At the same time, a GSM module sends a warning message to the user's mobile phone.

II. BLOCK DIAGRAM AND MAIN COMPONENTS

A. Block Diagram

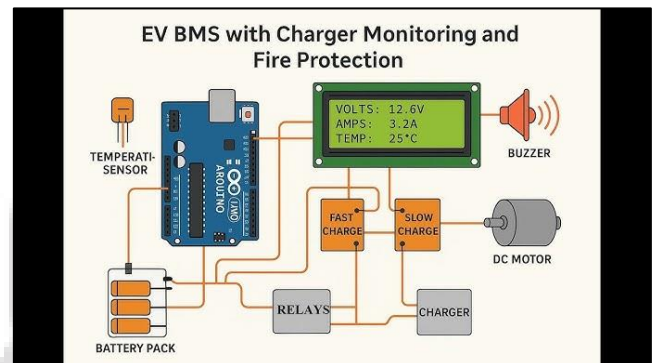

B. Components

1) LCD Display (20×4)

It is used to display battery information like voltage, current, and temperature so the user can easily see the battery condition.

2) Arduino UNO

It is the main control unit of the system. It receives data from sensors and decides what action to take, such as turning ON/OFF the relay, buzzer, or GSM module.

3) Relay Module (2 Channel)

It works like an automatic switch. It is used to connect or disconnect the battery from the charger or load when a fault condition occurs.

4) I2C Converter

It is used to reduce the number of wires between Arduino and LCD. It makes the connection simple using only two wires (SDA and SCL).

5) DHT11 Sensor

It is used to measure the temperature (and humidity). In this project, it mainly helps in detecting battery overheating.

6) Voltage, Current, and Temperature Sensors

These sensors measure battery voltage, charging/discharging current, and temperature. They help in monitoring battery health and safety.

7) 12V Battery

It is the power source of the system. It supplies energy to the motor and other components.

8) *GSM Module (SIM800L)*

It is used to send alert messages to the user's mobile phone when overheating, overcharging, or fire risk is detected

III. WORKING PRINCIPLE

- 1) The battery is connected to the system and supplies power to the circuit.
- 2) Sensors are used to measure battery voltage, current, and temperature continuously.
- 3) These sensor values are sent to the Arduino microcontroller.
- 4) Arduino checks whether the battery values are within safe limits.
- 5) This disconnects the battery from the charger and load to prevent damage.
- 6) The buzzer gives an alarm to indicate fault condition. At the same time, the GSM module sends an alert message to the user's mobile phone.
- 7) A DC-DC buck converter provides required voltage to Arduino and other components.
- 8) Thus, the system continuously monitors the battery and takes automatic action during unsafe conditions

IV. ADVANTAGES

- 1) 1.It protects the EV battery from overcharging and overheating.
- 2) 2.It reduces the chances of fire accidents in electric vehicles
- 3) 3.It increases the life of the battery.
- 4) 4.It gives alert messages to the user using GSM.

V. APPLICATIONS

- 1) Electric vehicles (EVs).
- 2) Battery-powered bikes and scooters.
- 3) Solar battery systems.

VI. CONCLUSIONS

This project shows how an EV Battery Management System with Fire Protection and GSM can be used to improve battery safety. The system continuously monitors battery voltage and temperature using sensors. When abnormal conditions are detected, it disconnects the battery and activates the fire protection system. It also sends an alert message to the user's mobile phone through GSM.

This project helps in preventing battery damage and fire accidents. It increases battery life and makes the system more reliable and safer. The system is simple, low cost, and easy to implement. It can be used in electric vehicles and other battery-operated systems where battery safety is very important. Hence, this project is useful for improving safety in electric vehicles and energy storage systems.

REFERENCES

- [1] International Organization for Standardization – ISO 26262 (Road Vehicle Functional Safety)
- [2] UL Solutions – UL 2580 (EV Battery Safety Standard)
- [3] International Electrotechnical Commission – IEC 62660 (Lithium-ion Cell Testing)