

Performance Evaluation of Hysteresis Controlled SEPIC Converter for EV Battery Charging System

G. Govindha Samy¹ Meene D² Dr. V. Padmathilagam³ Dr Baskaran B⁴

^{1,2}Research Scholar ³Associate Professor ⁴Professor

^{1,2,3,4}Department of Electrical Engineering

^{1,2,3,4}Annamalai University, India

Abstract — The Quality of power is improved by using SEPIC converter with a Cascaded PI controller, which is utilized in battery charging of EV (Electric Vehicles) applications. The cascaded PI controller improves the voltage gain with minimum switching losses. The presented topology will work in buck mode and boost mode of operation reliant on the rectified voltage at the input side and battery voltage at the load side. The steady-state switching frequency is estimated by the hysteresis-controlled PWM generator. The overall performance of the proposed converter is validated using MATLAB simulation.

Keywords: Hysteresis Controlled SEPIC Converter, EV Battery, Charging System

I. INTRODUCTION

Now a days the demand of electricity generation from renewable energy is increasing for domestic to industrial applications. The electricity generated from fossil fuels cause rising of toxic gases in the atmosphere. These fossil fuels are decreasing bit by bit in the environment. Solar energy is one of the most abundant renewable energy resources, eco-friendly, and pollution free. Sunlight is converted into electricity via solar cell using the photovoltaic effect [1]-[3]. For solar energy, system installation cost only is needed, if once installed it can run for a long duration and it can also save the overall maintenance cost. As Solar energy is versatile in nature, it can be used for different power applications from tiny torch to satellite.

Lossless, eco-friendly power generation is the emerging technique in modern civilization. The role of renewable energy becomes more popular, as they do not violate the environment and surroundings. They consume less area for installation and processing. Some of the renewable power resources are listed below: Solar, wind, tidal, hydro, biogas, geothermal, etc.

Depending upon the location and resource availability, the power plants are located. Among the all, nearly half of the power generation in India completely depends upon PV system. This system uses the natural sunlight to generate electricity.

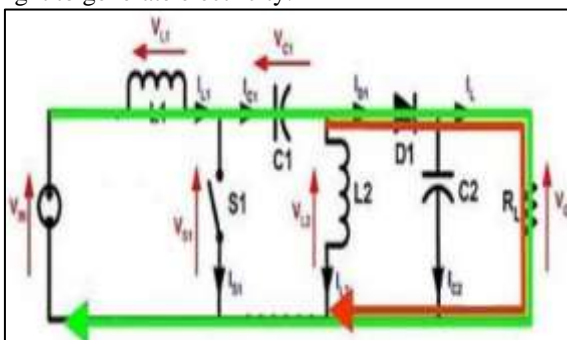

Fig. 1: Schematic SEPIC Converter

Some topologies for power generation to satisfy the load requirement are converters, control techniques, switching actions, filters, etc. These techniques determine the power quality and satisfy the load requirement. The output power is stepped-up or stepped-down in accordance with the load.

The evolution of dc-dc converters for renewable power generation has been growing day-to-day. Lot of dc-dc converters are available. Some converters perform both buck and boost operation in a single track. Cuk Converters, Buck Boost Converters, Sepic Converters and the Zeta Converters are some of the boost and buck converters. The operation of SEPIC converters, its merits and demerits are more are also discussed.

II. CONFIGURATION OF PROPOSED CONVERTER

A. Sepic Converter

Fig. 2(a) displays the SEPIC converter MODE 1. SEPIC converter performs both buck and boost operation. L acts as a filter for input current directly feeding the resistive load and C acts as filter for the output voltage. The coupling capacitor transfers energy from input to output.

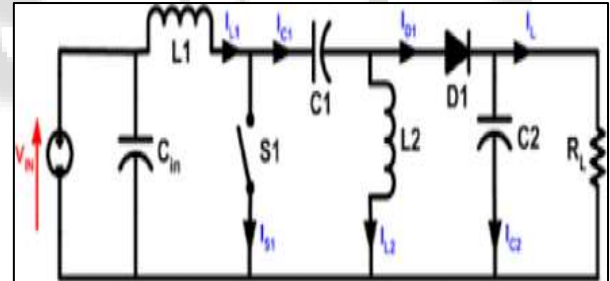

Fig. 2(a): SEPIC Converter Mode 1

The proposed SEPIC converter topology features two modes of operation:

- 1) Switch in ON condition
- 2) Switch in OFF condition

Mode 1: Switch is turned on; input voltage charges the L1 and C1.C2 energies the inductor L2. Diode D1 becomes reversed-biased and output is controlled by the C2.

Mode 2: The switches are placed off and the diode is forward-biased. The L1 discharges while the power in the L2 is sent to the respective loads.

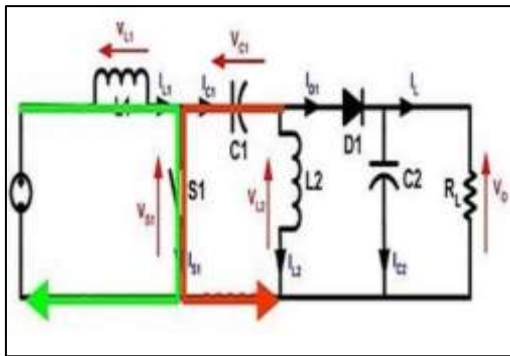

Fig: 2(b): SEPIC converter Mode 2.

Based on the output power requirement the converters have been designed and modelled in MATLAB/SIMULINK. The SEPIC converter can either increase or decrease an input voltage by controlling the Duty Cycle of a pulse to the MOSFET. One way to do that is to directly control the Duty cycle using a potentiometer. [13-15]

The SEPIC converter is essentially a boost converter followed by an inverted buck-boost converter. Therefore it is similar to a traditional buck-boost converter, but has the advantage of having non-inverted output (the output has the same voltage polarity as the input), using a series capacitor to couple energy from the input [16-18].

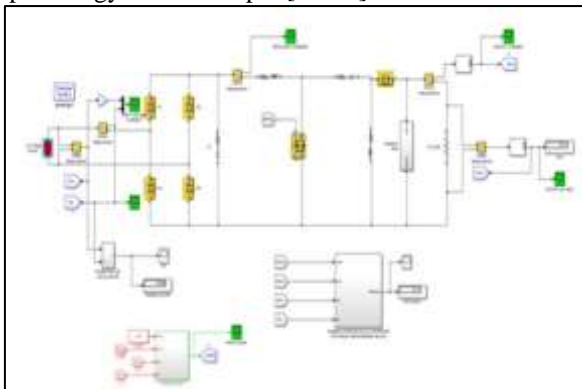

Fig. 3: Simulink Circuit of SEPIC Converter

Fig. 3. shows the Simulink circuit of the SEPIC converter based on the ON or OFF state of the static switch S.

If the capacitor impedance is minimum when comparing to the resistance R2 at a switching frequency f_s , then

$$1/(2\pi [f_s C]_{-1}) \ll R2 \quad (1)$$

The capacitor voltage C1 changes linearly and the voltage slope is generally estimated by the time constant (TC) [19-20] and maximum output level V_P . The switching frequency is given by,

$$f_s = \frac{DV_{CP}}{V_{HTC}} \quad (2)$$

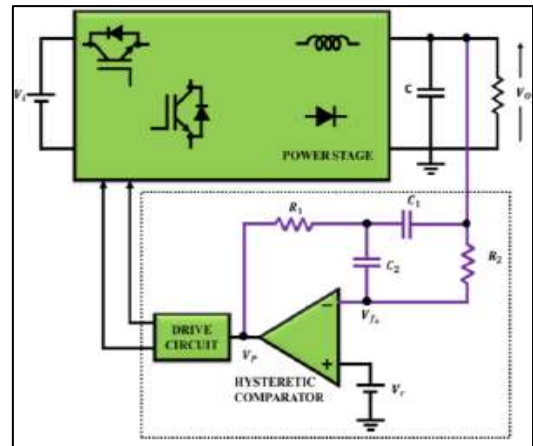

Fig. 4: Hysteresis-controlled PWM circuit

III. RESULTS AND DISCUSSION

To demonstrate the effectiveness of the proposed converter, the above discussed is simulated in MATLAB. The converter is tested under open loop mode. Fig.5 indicates the current and fixed voltage waveform of the AC source, which varies from +2.5A to -2.5A and gradually decreases from +2A to -2A.

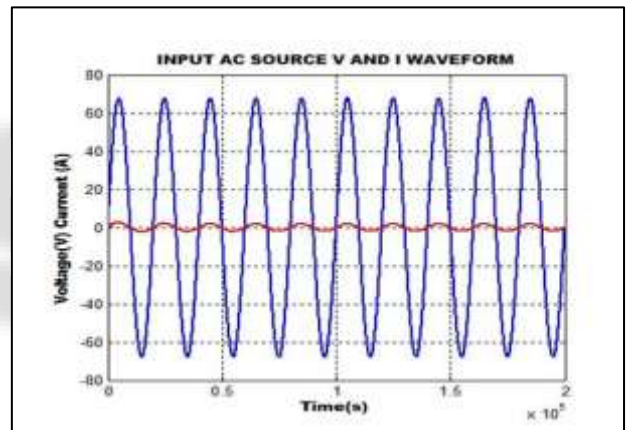

Fig. 5: Input AC source V and I waveform

Both waveforms are sinusoidal in nature. The range of voltage is Fixed from +60V to -60V. Fig. 6(a) and 6(b) represent the PWM pulse waveform to switch 1 and switch 2.

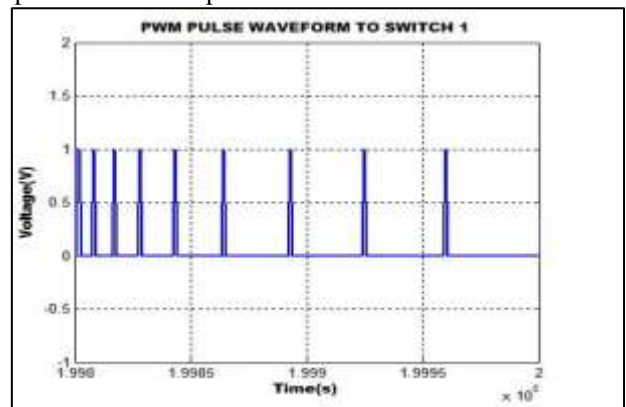

Fig. 6(a): PWM pulse waveform to switch 1

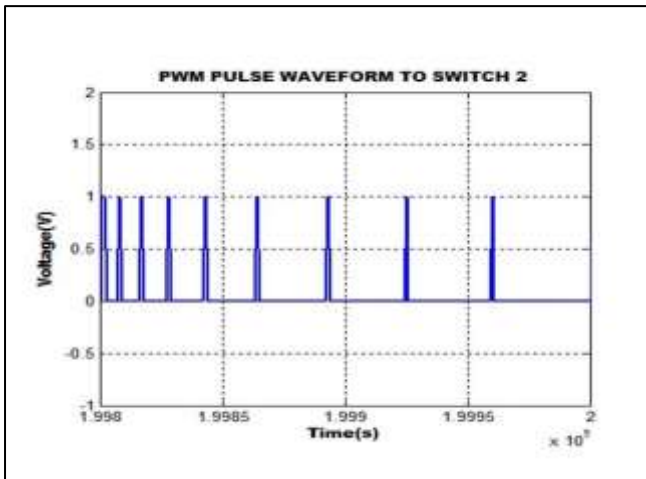

Fig. 6(b): PWM pulse waveform to switch 2

Fig. 7(a) and 7(b) represents the Load current and Load voltage waveform.

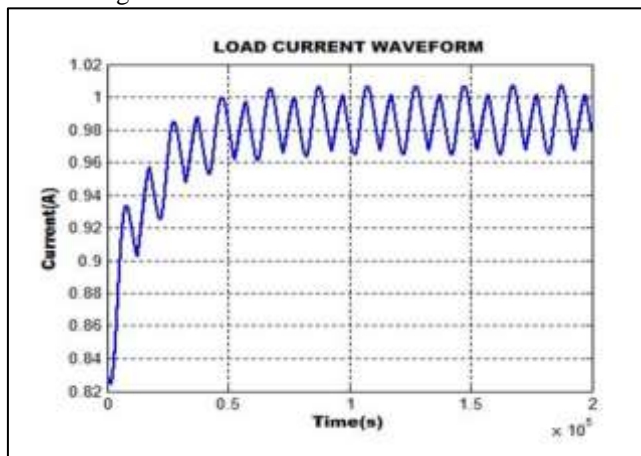

Fig. 7(a): Load current waveform

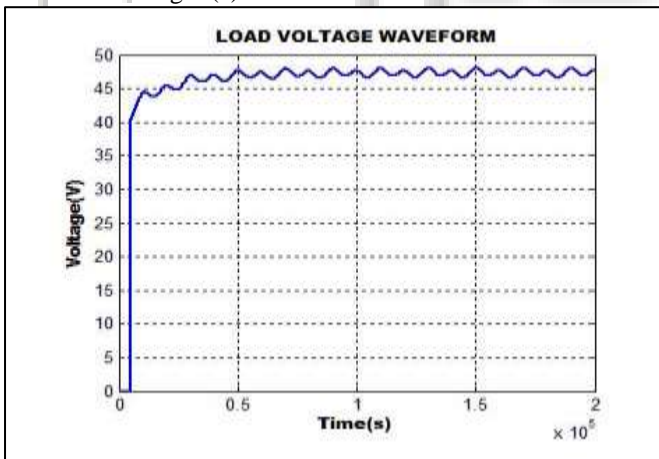

Fig.7(b): Load voltage waveform

Fig.8 indicates the Output power waveform and Fig.9. Represents the power factor waveform of the converter and the unity power factor is approximately maintained.

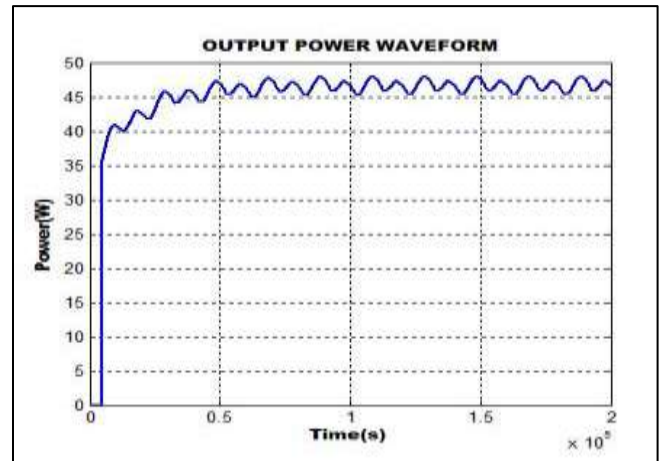

Fig. 8: Output power waveform

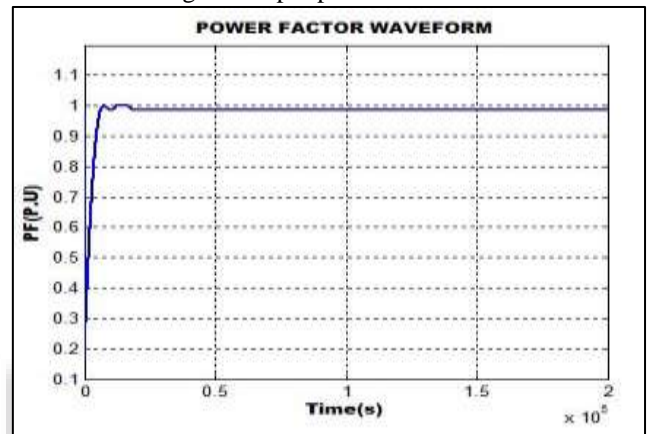

Fig. 9: Power factor waveform

IV. CONCLUSION

The proposed SEPIC based DC-DC converter is designed for solar application. The converter was controlled by Hysteresis-controlled PWM circuit. The output of the proposed converter is presented and analyzed.

ACKNOWLEDGEMENT

We wish to express our sincere thanks to RUSA 2.0 for providing us the opportunity to carry out the project on Eco-Friendly Electric Vehicle involving various improved power quality buck-boost converter by magnanimous funding. Also we sincerely thank all the officials who are involved in getting us the financial assistance in the execution of the proposed work.

REFERENCES

- [1] Industrial Informatics, vol: 16, no: 4, pp. 2301 – 2314.
- [2] Longcheng Tan; Bin Wu; Venkata Yaramasu; Sebastian Rivera; Xiaoqiang Guo, 2016, "Effective Voltage Balance Control for Bipolar-DC-Bus-Fed EV Charging Station With
- [3] Three-Level DC-DC Fast Charger", IEEE Transactions on Industrial Electronics, vol: 63, no: 07, pp: 4031 – 4041.
- [4] [I] Rong-Jong Wai, Wen-Hung Wang, Chung-You Lin, "High- Performance Stand-Alone Photovoltaic

- Generation System" IEEE Transactions on Industrial Electronics, vol.55, no.1, pp.240-250, Jan.2008.
- [5] Mahrous E. Ahmed, MustafaMousa" Development of high gain and efficiency photovoltaic system using multilevel boost converter topology" 2010 2nd IEEE International Symposium on power Electronic for Distributed Generation System.
- [6] Yi Zhao, Wuhua Li, Van Deng,Xiangning He "Review of Non- Isolated High Step-Up DCIDC Converters in Photovoltaic Grid- Connected Applications" IEEE Transactions on Industrial Electronics, vol.PP, no.99,pp.1-1,2010.
- [7] Charanasomboon T, Devaney M.J, and Hoft R.G, "Single switch dual output DC-DC converter" Industry Application Society Annual Meeting,IEEE, Vol. 1, pp. 793-795, 1988.
- [8] Wing-Hung Ki, and Dongsheng Ma, "Single-inductor multipleoutput switching converters" Power Electronics Specialists Conference, PESe. 2001, vol. 3, pp. 301-304, 6-9 May. 2001
- [9] Power Factor Improvement in Modified Bridgeless Landsman Converter Fed EV Battery Charger; Article in IEEE Transactions on VehicularTechnologyPP(99):1-1•February2019;RadhaKushwaha;Bhim Singh
- [10] Modified SEPIC converter with high boosting capability; J.DivyaNavamani ; A. Lavanya ; K. Vijayakumar; Electronics Letters (Volume: 55 , Issue: 13 , 6 27 2019)
- [11] Power Factor Correction Using DC-DC SEPIC Converter Optimized With Fuzzy Logic Controller; M.Sangeetha, S.Kiruthika, R.Priyadharshini, K.Divya; International Journal of Innovative Research in Science, Engineering and Technology, Vol. 8, Issue3, March 2019
- [12] PV Integrated SEPIC Converter Using Maximum Power Point Tracking for Ac Loads; K. Mohanraj, B.Yokesh Kiran; International Journal of Recent Technology and Engineering (IJRTE) ISSN: 2277- 3878, Volume-8, Issue-1S4, June2019
- [13]RadhaKushwaha ; Bhim Singh; IEEE Transactions on Vehicular Technology (Volume: 68 , Issue: 4 , April 2019)
- [14]Mohammad Ekramul Kabir; Chadi Assi; Hyame Alameddine; Joseph Antoun; Jun Yan, 2020, "Demand-Aware Provisioning of Electric Vehicles Fast Charging Infrastructure", IEEE Transactions on Vehicular Technology, vol: 69, no: 07, pp: 6952 – 6963.
- [15]Duo Zhang;Guohai Liu;Huawei Zhou;Wenxiang Zhao, Year:2018, "Adaptive Sliding Mode Fault-Tolerant Coordination Control for Four-Wheel Independently Driven Electric Vehicles", IEEE Transactions on Industrial Electronics, vol.65, no.11, pp. 9090 – 9100.
- [16]Jiageng Ruan ; Qiang Song, Year: 2019, "A Novel Dual-Motor Two-Speed Direct Drive Battery Electric Vehicle Drivetrain", IEEE Access, Vol: 7, pp. 54330 – 54342.
- [17]Balaji Chandrasekar;Chellammal Nallaperumal;Sanjeevikumar Padmanaban;Mahajan Sagar Bhaskar;Jens Bo Holm-Nielsen;Zbigniew Leonowicz;Samson O. Masebinu,2020, "Non-Isolated High-Gain Triple Port DC–DC Buck-Boost Converter With Positive Output Voltage for Photovoltaic Applications", IEEE Access, Vol: 8,pp: 196500 – 196514.
- [18]Chen, Zhaoyi, Yuanrui Chen, and Zhixing Yan, 2020, "Simplified hysteresis sliding-mode control for superbuck converter", IEEE Transactions on Circuits and Systems II: Express Briefs, Vol: 67, No: 12, pp: 3212-3216.
- [19]Kumaran Nathan;Saikat Ghosh;Yam Siwakoti;Teng Long, 2019, "A New DC–DC Converter for Photovoltaic Systems: Coupled-Inductors Combined Cuk-SEPIC Converter", IEEE Transactions on Energy Conversion, Vol: 34, No: 1, pp: 191 – 201.
- [20]M. Brenna, F. Foiadelli, C. Leone, and M. Longo, 2020, "Electric vehicles charging technology review and optimal size estimation", J. Electr. Eng.Technol, vol. 15, pp. 114.
- [21]S. Habib, M. M. Khan, F. Abbas, and H. Tang, 2018, "Assessment of electric vehicles concerning impacts, charging infrastructure with unidirectional and bidirectional chargers, power comparisons," Int. J. Energy Res., vol. 42, no. 11, pp. 34163441.
- [22]J. Van Mierlo, M. Bercibar, M. El Baghdadi, C. De Cauwer, M. Messagie,T. Coosemans, V. A. Jacobs, and O. Hegazy, 2021, "Beyond the state of the art of electric vehicles: A fact-based paper of the current and prospective electric vehicle technologies,"World Electr. Vehicle J., vol. 12, no. 1, p. 20.