

Voltage Regulation Using PV-DVR under Various Source Unbalance Conditions

Vinay Sarje¹ Dr. Manju Gupta² Dr. Geetam Richhariya³

^{1,2,3}Department of Electrical & Electronics Engineering

^{1,2,3}OIST, Bhopal, Madhya Pradesh,, India

Abstract — DVR is a series connected power converter dedicatedly installed in-order to regulate the load bus voltages and also to protect the sensitive loads against the voltage fluctuations. The DVR monitors the voltage at the point of connection, sense it and by comparing it to a preset reference voltage it injects the required voltage to maintain the rated value. DVR is designed by series connection of a three phase voltage source converter connected through Coupling Transformer (CT). Conventionally, DVR is designed in voltage control topology but can also be designed in current control mode. AC side of the converter is connected to the three-phase terminal of the CT. The CT in-turn connect the DVR to the transmission line. The DC-side of the DVR is connected across the DC-Battery, conventionally this battery can be charged via grid. In this paper the battery is charged via solar photo-voltaic system. Hence this work proposes the DVR-PV for voltage regulation under various operating conditions of sag and swell in source as well as harmonics and including momentary fluctuations and voltage interruptions. This paper analysis the LLL-G fault, LL-G fault and short term voltage interruption with harmonics injection of the different order in source.

Keywords: Dynamic Voltage Restorer (DVR), Coupling Transformer (CT), Power Quality Issues (PQI), Voltage Source Converter (VSC), Solar Photo-Voltaic System

I. INTRODUCTION

The advancement in Power Electronic Technology (PET) has both advantage and disadvantage. Advantages are availability of versatile devices with which work can be accomplished with high precision and efficiency. On the other hand, its high usage deteriorate the voltage-current profile leading to the injection of high harmonic content both at grid side as well as load side. Also, the present-day system is highly burdened which leads to the problem of voltage stability [2]. Voltage Sag/Swell (VSS) can cause the malfunction of voltage-sensitive loads in hospital, factories and commercial buildings, where sever process disruptions resulting in substantial economic and/or data losses. Any type of faults, likewise single-line/double-line fault, line-to-ground fault, symmetrical faults in system, the switch-in of large induction motors, curtailment of large loads and switching out of large power transformers [2]. Dynamic Voltage Restorer (DVR) is a compensating device designed via-power electronic converters installed at distribution side to regulate the load-bus voltages. Distribution system frequently suffers the voltage sag and swell events which deteriorate the quality of power supply. Hence to retain the power quality DVR is installed at load side which regulates the load bus voltages. The distribution transformer's load side voltage is monitored by the DVR, which then compares it to a reference voltage. In order to swiftly restore the voltage at the load to its nominal value after a Voltage Sag/Swell VSS, the DVR quickly

injects a voltage waveform with the grid voltage's opposite polarity and amplitude [3]. The converter connected, that is managed by a digital signal processor produces the waveform. It injects the series voltage into the system to remove the voltage difference also it supplies the required reactive power to mitigate the PQ issues generated due to fluctuations, transients or flickers in system voltages. It also reduces the harmonics generated in the system due to non-linear loading [4].

The compensation of voltage provided by DVR by ranges typically up to 50% of the nominal voltage. The compensation time is typically in the range of a few milliseconds to a few seconds, depending on the magnitude of the voltage disturbance.

The prime apparatuses of a DVR include the voltage sensor, the digital signal processor, the power electronics circuit, the energy storage device, and the transformer. The energy storage device is typically a bank of capacitors, which are used to store energy and provide the fast response required to compensate for voltage disturbances. In this work the capacitor banks are charged via solar power. This paper analysis the performance efficiency of the proposed DVR-PV under the condition of symmetrical three-phase faults and the unsymmetrical double-line to ground fault. Results are compared with and without compensation and THD of the respective cases are compared to validate the efficiency of the work.

II. DVR-PV DESIGN AND CONTROL

Dynamic Voltage Restorer (DVR) is a customized power conditioning device dedicatedly designed for VSS compensation. It is generally employed in distribution system near load. Depending upon the requirement of PQ mitigation it has numerous topologies. It has wide range of applications starting from generalized compensation to the precise one [5]. A conventional DVR mainly consists of a Voltage Source Converter (VSC) which is connected series, an energy storage element and an injection transformer [6]. The fundamental of DVR is to inoculate a voltage of the obligatory amplitude, frequency and phase angle and in successions with distribution feeder. The VSC generates the required voltage using the dc voltage provided by the dc link and energy storage. The DVR feed the filtered output voltage generated by VSC and injected in series injection transformer. For load voltage regulation and harmonics mitigation DVR is installed near load end. It is a series connected device connected via coupling transformers. It infuses dynamically controlled voltage of appropriate magnitude and phase [7]. A solar-connected DVR uses a solar panel to provide power to the device, making it more environmentally friendly and cost-effective compared to traditional voltage restorers that rely on grid power. The solar panel charges a battery, which can be

used to power the DVR and maintain continuous operation even during power outages [8-10].

Solar-connected DVRs are commonly used in remote locations or in areas with unreliable power supply. They help to improve the reliability and quality of power supply to critical equipment such as medical devices, communication systems, and industrial machinery. The schematic of DVR_PV is shown in figure-1, from the figure it can be observed that it comprises of coupling transformer to connect the VSI in series with the power line. The VSI is supplied by a DC source which in this case is PV. The AC output obtained from VSI is contains high number of harmonics, since VSI is a power converter designed using high frequency switches [11]. Therefore, a filter is connected designed using electrical lumped parameters. The voltage across the transformer is the DVR injected voltage which is added to the system in order to maintain load voltage or output voltage at load side [12-14].

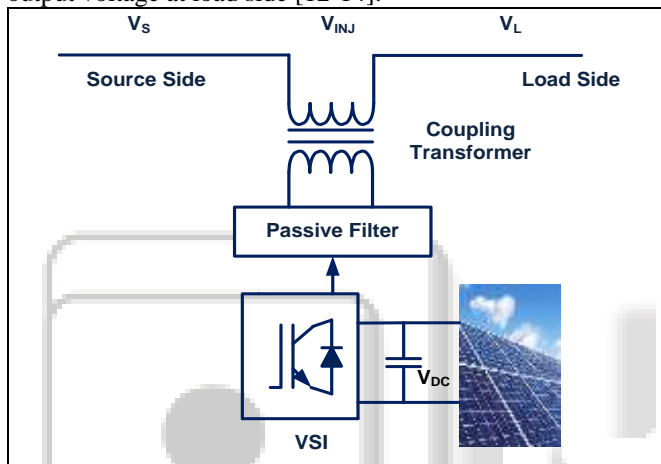

Fig. 1: Single-line diagram of DVR-PV

III. PV-ARRAY MODELLING

In this work PV-array supplies the power converter connected to the DVR circuit. The DVR plays a vital role in maintaining the load bus voltages at various modes of operation such as temporary outage of transmission line due to severe environmental conditions or three phase short circuits. Under the condition of long-time outages, PV behaves as microgrid and isolate itself from the rest of the circuits in order to avoid any damage to the inverter circuit due to high harmonics of transients. Under such conditions, PV supplies the reactive power demand so as to restore the load bus voltages. Also it provides the active power to the priority loads connected in the circuit.

In this work PV is designed using renewable solar energy block available in matlab library. A series parallel combination of 4/4 is used to generate power 4.5KW and voltage 200V. The PV generates power which is fluctuating in nature. Hence a boost circuit is connected as shown in figure 2 to stabilize the DC-output of the solar.

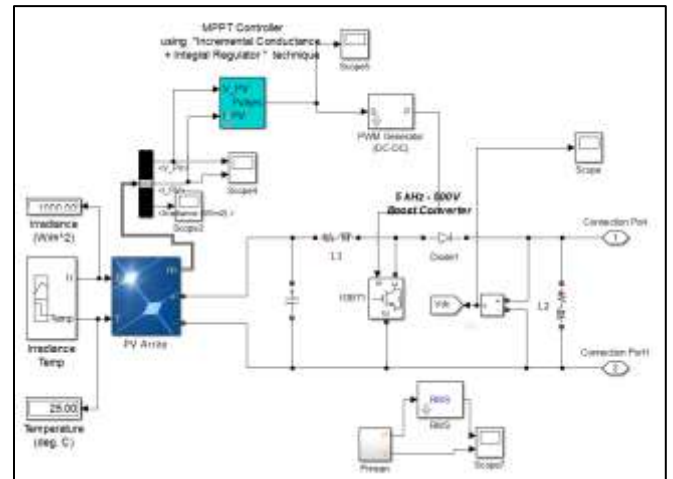

Fig. 2: PV-boost circuit

IV. SIMULATION MODEL

The complete simulation model of the proposed topology is shown in figure 3. The system is designed in matlab simulink tool-kit. To represent the grid, a three phase voltage source block is used. At load side a parallel linear load of 1.5 KW is connected. The DVR is designed via two-level inverter block available in power electronics library. The DC- side of the inverter is connected across the DC-battery, a PV-array modeled in the renewable library to generate the 4.5 KW watt of power at 200 rated voltage as shown in subsystem block. The inverter is followed by the filter unit whose ratings are given in table-1. The control for generating gate pulses for DVR-switches is designed using conventional PI controller connected with the help of delta connected coupling transformer to the distribution system. The faults are created using the fault block to analyse the system under the condition of three-phase symmetrical and double-line to ground unsymmetrical fault. The circuit are synchronized using discrete phase lock-loop as shown in figure 4. This circuit forms the closed loop control in which reference signals are cast using synchronous frame theory which extract the source voltages and currents of the grid.

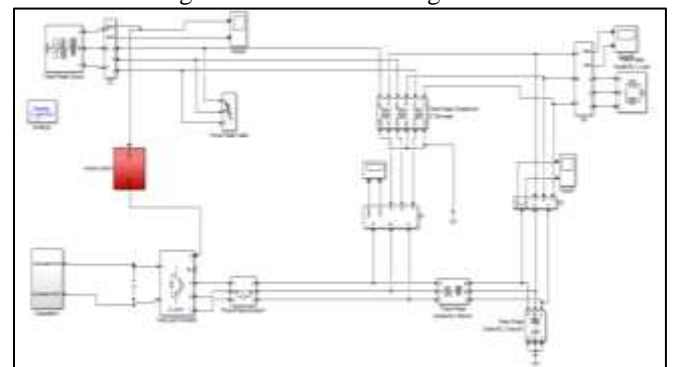

Fig. 3: Simulation model of the proposed DVR-PV

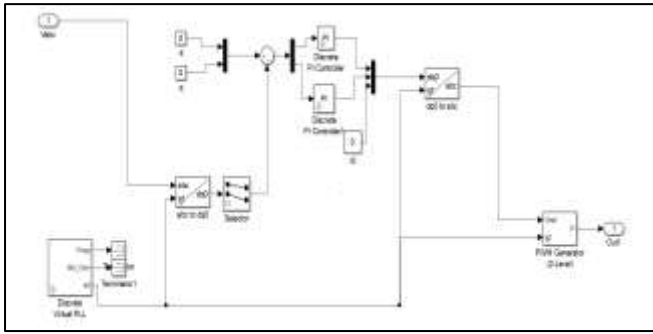

Fig. 4: Controller for pulse control in DVR

V. RESULT DISCUSSIONS

A. CASE-1 Symmetrical three phase fault (LLL-G)

The performance of the proposed DVR-PV customized for the power quality improvement in a distributed system is analysed for three-fault at source side for the duration of 0.4-0.8 sec. The results are compared with and without compensation. After the occurrence of three phase short circuit at source side, the source voltage is interrupted for long duration and the fault current is very high as shown in figure 5(a). This will also generate high harmonics of the

order of 23.59 %. When the DVR is not connected, the load voltage as well as load current suffers the condition of sag as shown in 5 (b), and this may affect the various sensitive load connected since load voltage harmonics will also be high of 23.5%. When DVR-PV is connected it injects the reactive current as shown in figure 5(c) to retain the load voltage to the normal value and the short circuit in source does not affect the load bus also it will eliminate the harmonics and the its value is about 1%. The only disadvantage with the proposed PV connected DVR is it take nearly 2 seconds to stabilize. But as soon a it stabilizes one cannot find the traces of voltage injection during the sag recovering. The load voltage is almost constant and smooth.

S.No.	System Parameter	Rating/Values
1	DC_bus voltage	200V
2	Main supply voltage (line-line, rms), frequency	415V, 50Hz
3	PI gain [Kp, Ki] of PLL	[0.5, 50]
4	3-phase transformer power, turn ratio and frequency	30 kVA, 1:1, 50Hz
5	L and C of passive filter	20mH, 350μF

Table 1: Design Parameters of DVR

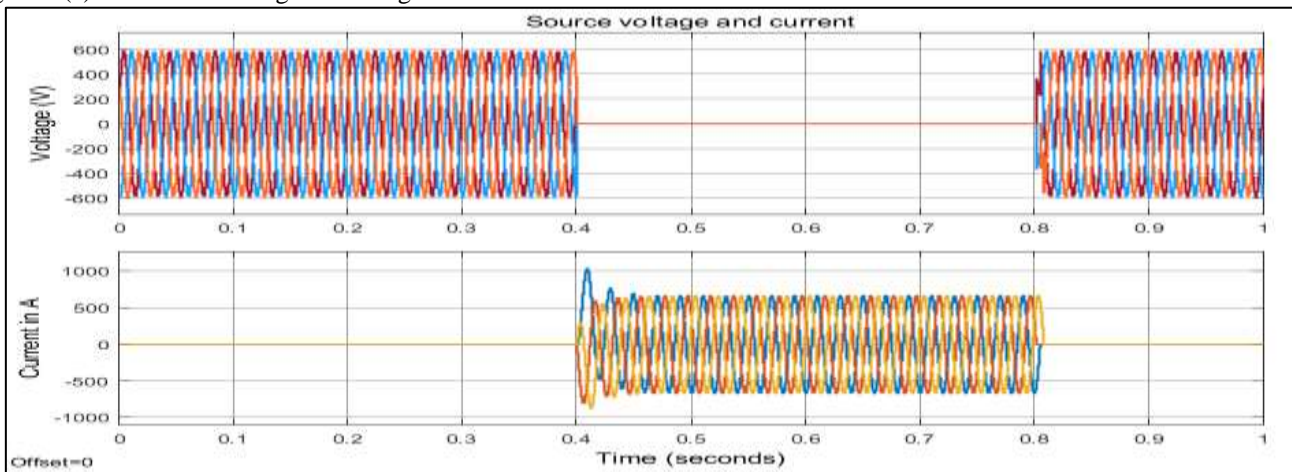

(a)

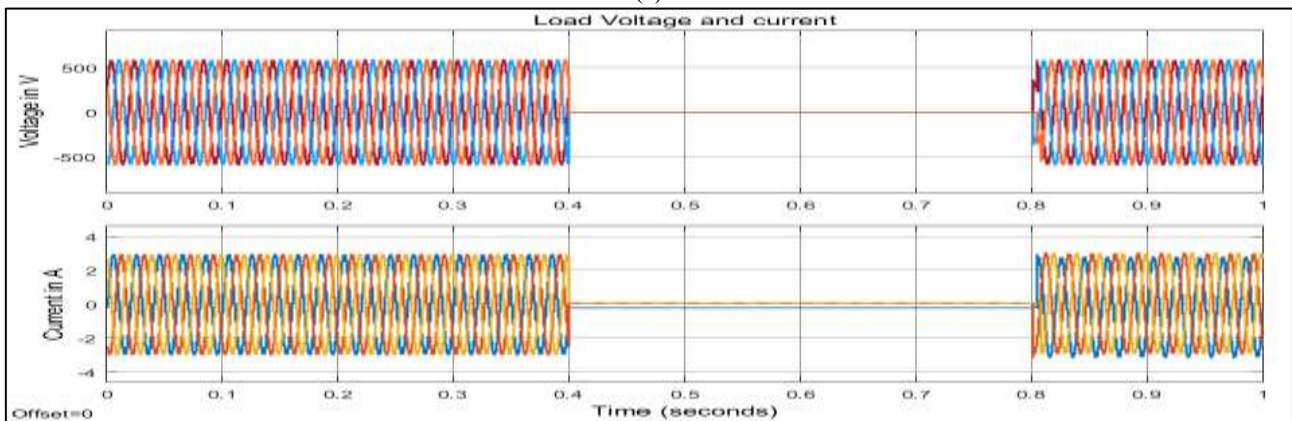

(b)

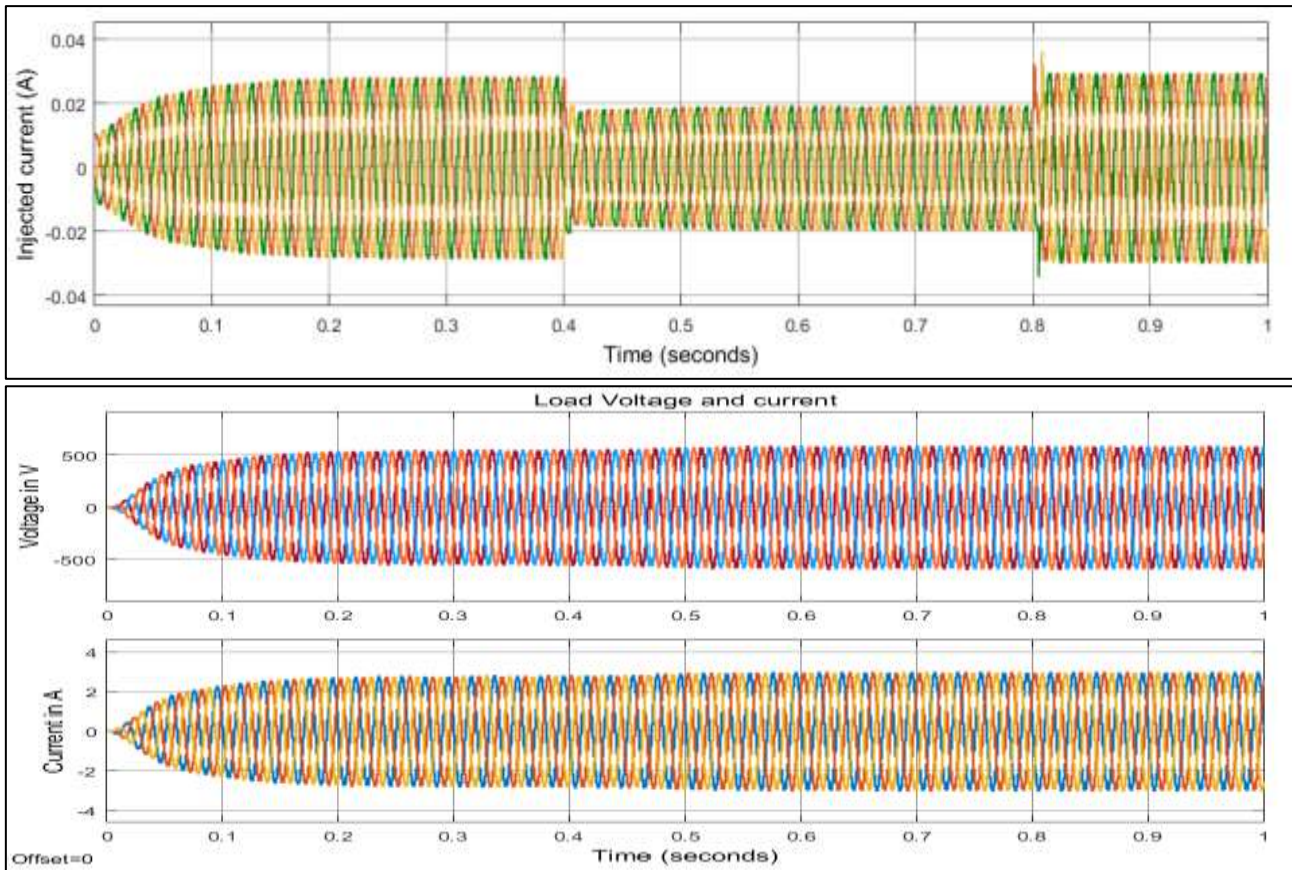

(c)

Fig-5: Case-1 Short circuit fault (a) source voltage-current (b) Load voltage and currents without DVR (c) (c) Injected current (d) Load voltages and current with DVR-PV

B. CASE-2 Un-Symmetrical Double-Line to Ground Fault (LL-G)

To analyse the performance of the proposed DVR under the condition of un-symmetrical faults a double-line ton ground fault is created for the duration of 0.4-0.8 seconds. The fault resistance is kept 0.7 sec. under this condition the two phases of the source voltage is reduced to 40 % of its original value

as shown in figure 6 (a). Without any compensation the load voltage and current phases will undergo sag and it will inject high harmonics of the order of 22%. The load voltage will attain a stable value with proposed DVR-PV which injects the reactive current as shown in figure 6(c), also it will reduce the harmonics to the considerable value of 1.4%.

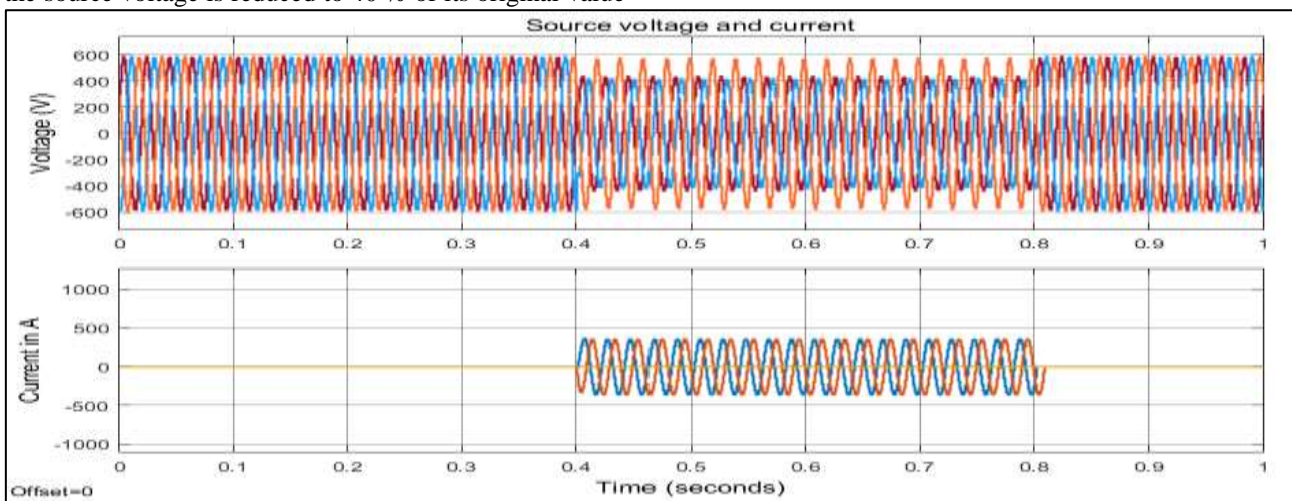

(a)

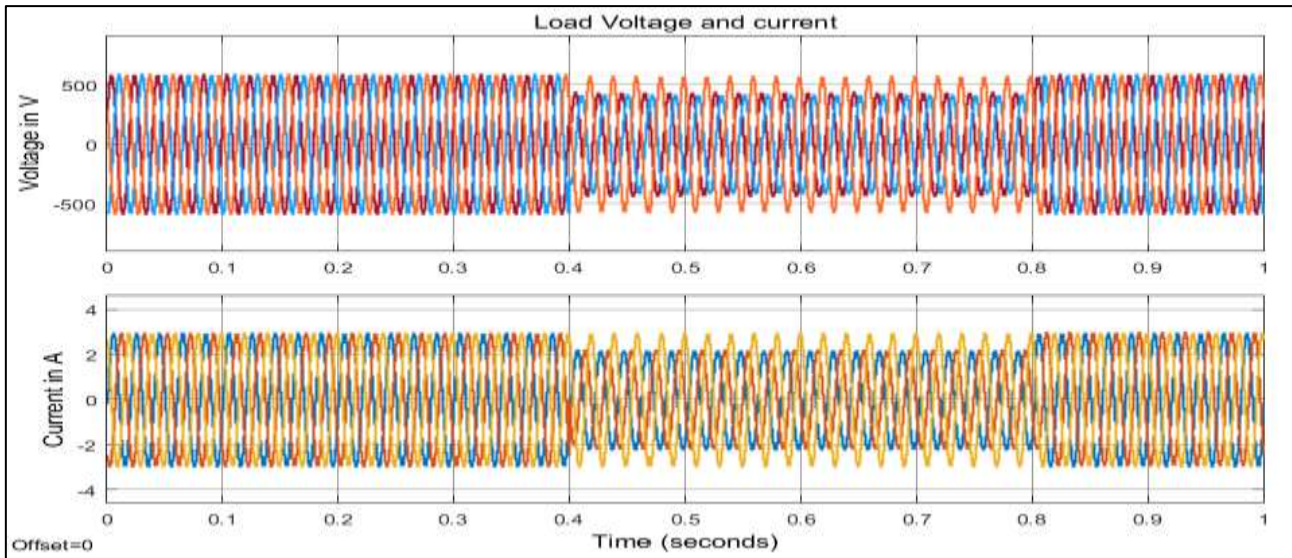

(b)

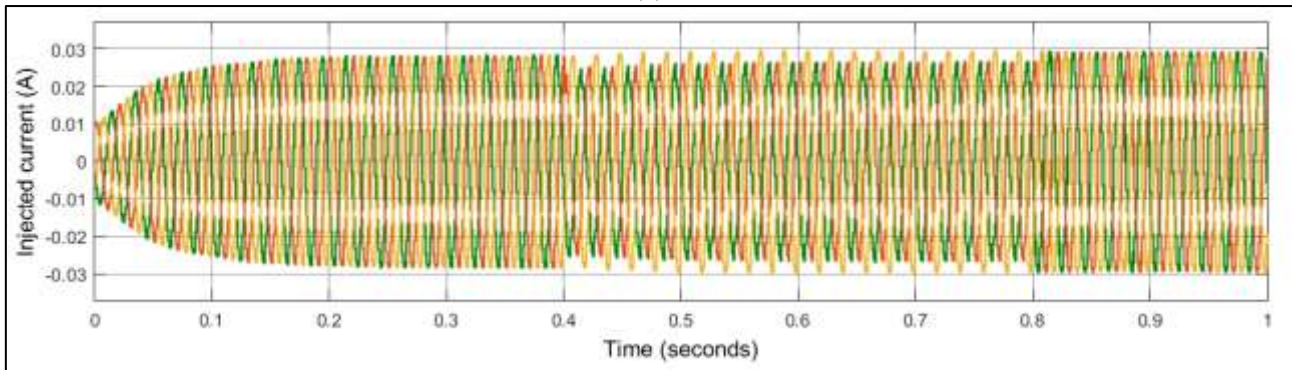

(c)

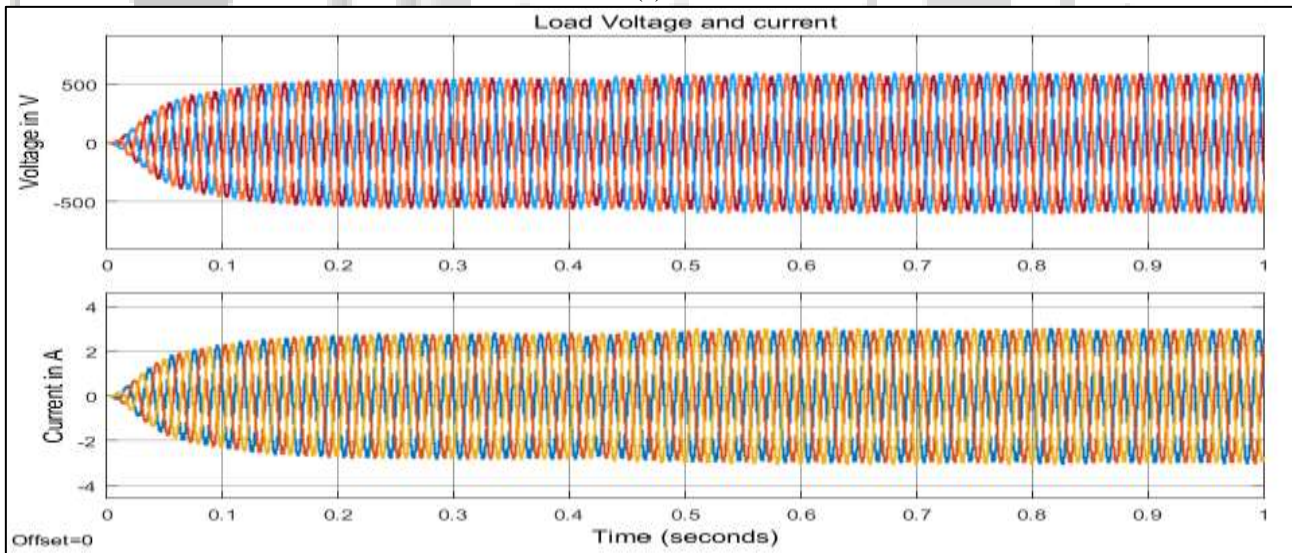

(d)

Fig-6: Case-2 Double-line to ground fault (a) source voltage-current (b) Load voltage and currents without DVR (c) Injected current (d) voltages and current with DVR-PV

C. CASE-3 Short Duration Voltage Interruption and Harmonic Injection

In this case a condition of voltage interruption is created for the duration of 0.2-0.7 sec. as well as 2nd and 3rd order harmonics are also injected at source side with 0.2 magnitude and -35 degree are super imposed with the fundamental

voltage wave form. The source and load bus results are shown in figure 7 (a) and (b). The harmonics are injected at 0.2 sec and continues to distort till 0.7 sec. during this variation, the THD varies between 15-22 % at source current and between 300% to 15 % at source voltages. With the DVR connected the THD at the load bus it maintained at 1.8% both in current and voltage waveforms.

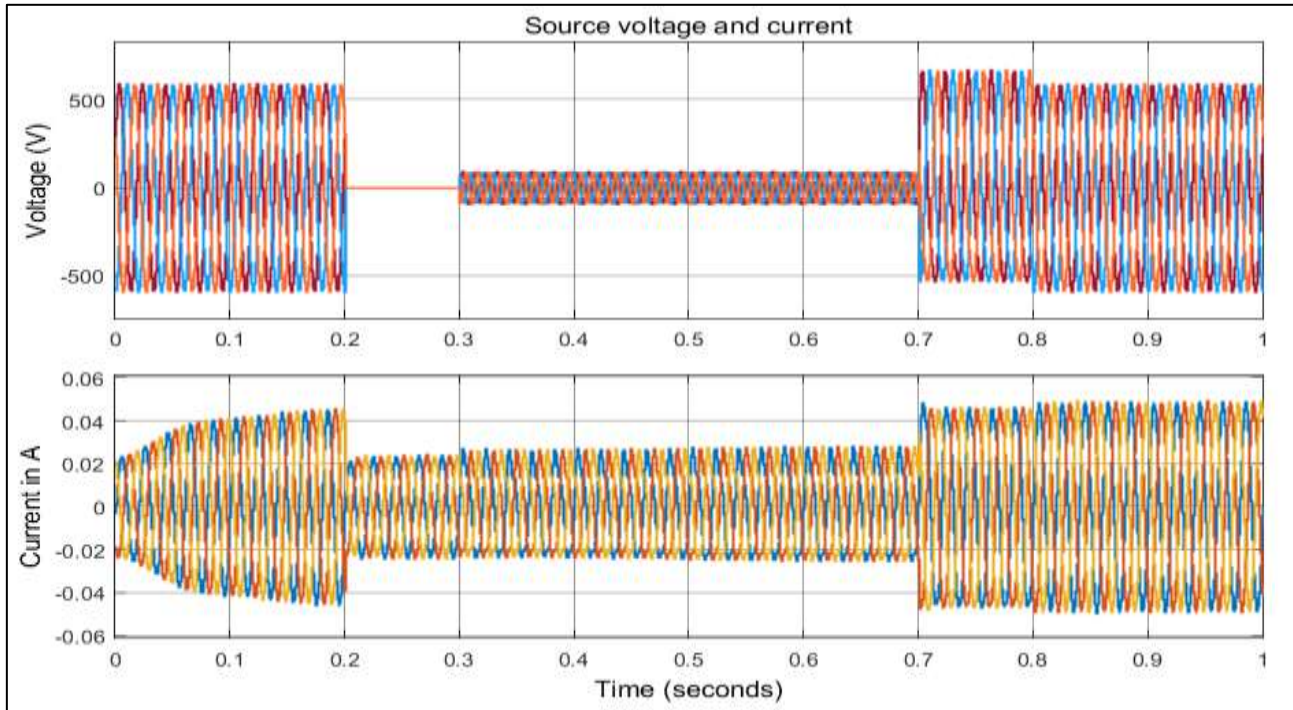

(a)

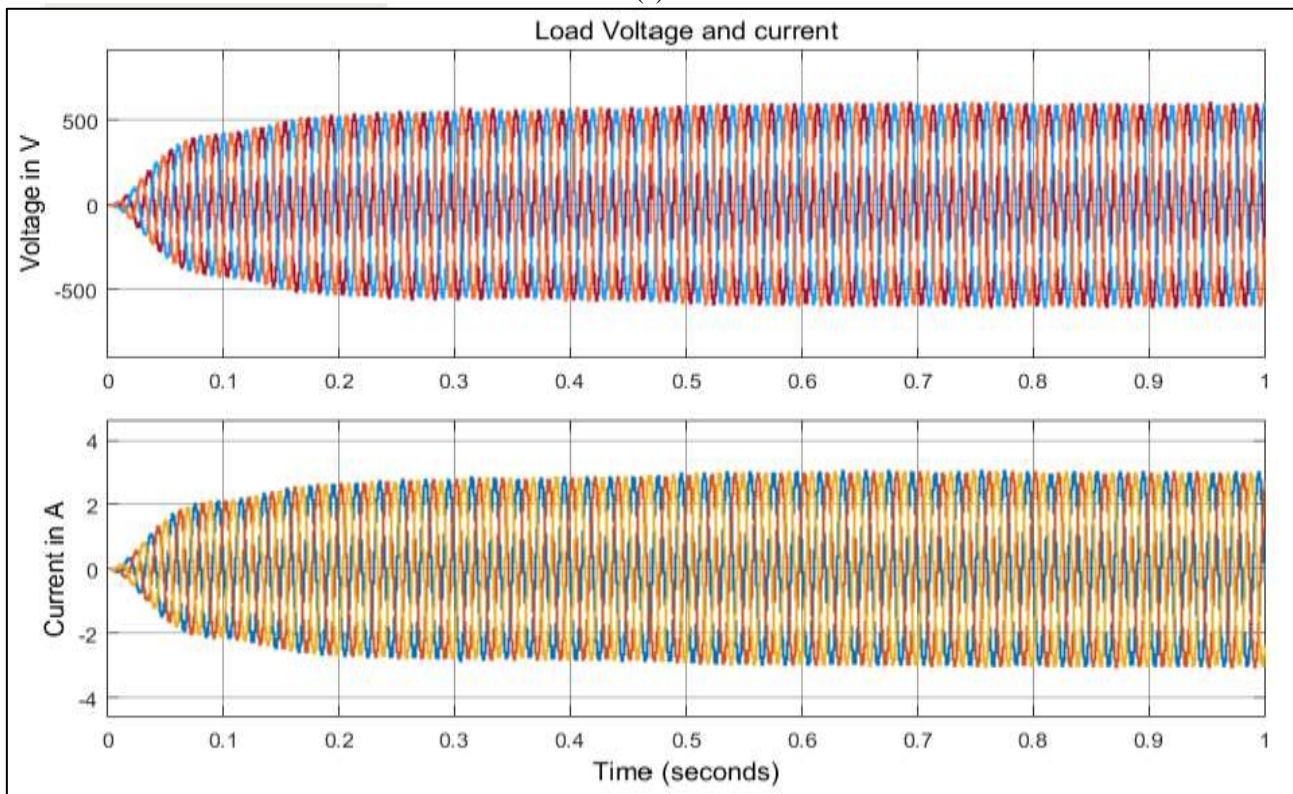

(b)

Fig. 7: Case-3 voltage interruption and harmonic injection (a) source voltage-current (b) Load voltage and currents with DVR

VI. CONCLUSIONS

This work presents a DVR which is interconnected with solar power generation to enhance the power quality of the distribution system. A DVR works by injecting a voltage waveform into the power system that is in-phase and equal in magnitude to the voltage distortion. The injected voltage

helps to restore the voltage to the required level and provides uninterrupted power supply to the connected equipment. The solar system makes it more economical and environmental friendly. Also for severe environmental conditions like heavy rain fall or storm when supply interrupts, PV provides the power to the priority loads in addition of retaining the system voltage stability. In this work DVR-PV proposed is analyse

for short circuit and LL-G faults as well as short duration voltage interruption with 2nd and 3rd order harmonic injection. In addition to mitigate the voltage instability condition at a load bus, it also reduce the harmonics in the system generated due to fault. Hence it helps in maintaining the quality of the supply.

REFERENCES

- [1] Farooqi, A., Othman, M. M., Radzi, M. A. M., Musirin, I., Noor, S. Z. M., & Abidin, I. Z. (2022). Dynamic voltage restorer (DVR) enhancement in power quality mitigation with an adverse impact of unsymmetrical faults. *Energy Reports*, 8, 871-882.
- [2] Dugan RC, McGranaghan MF, Beaty HW, Santoso S (1996) *Electrical power systems quality*, vol 2. McGraw-Hill, New York.
- [3] Remya, V. K., Parthiban, P., & Ansal, V. (2018). Dynamic voltage restorer (DVR)—a review.
- [4] Pal, R., & Gupta, S. (2020). Topologies and control strategies implicated in dynamic voltage restorer (DVR) for power quality improvement. *Iranian Journal of Science and Technology, Transactions of Electrical Engineering*, 44(2), 581-603.
- [5] Mohammed, A. B., Ariff, M. A. M., & Ramli, S. N. (2020). Power quality improvement using dynamic voltage restorer in electrical distribution system: an overview. *Indonesian Journal of Electrical Engineering and Computer Science (IJEECS)*, 17(1), 86-93.
- [6] Abas, N., Dilshad, S., Khalid, A., Saleem, M. S., & Khan, N. (2020). Power quality improvement using dynamic voltage restorer. *IEEE Access*, 8, 164325-164339.
- [7] Ghatge, V. V., & Naik, A. V. (2018, February). Implementation of Multilevel inverter based Dynamic voltage restorer. In *2018 Second International Conference on Computing Methodologies and Communication (ICCMC)* (pp. 856-859). IEEE.
- [8] Babaei E, Kangarlu MF (2009) A new topology for dynamic voltage restorers without dc link. In: *Proceedings of ISIEA*, pp 1009–1014.
- [9] Rai, S., Kumar, Y., & Kirar, M. (2021). TECHNOLOGICAL ADVANCEMENTS IN GRID INTEGRATION OF SOLAR ENERGY: A REVIEW. *Suranaree Journal of Science & Technology*, 28(4).
- [10] Babaei E, Kangarlu MF (2011) Voltage quality improvement by a dynamic voltage restorer based on a direct three-phase converter with fictitious DC link. *IET Gener Transm Distrib* 5(8):814–823.
- [11] Jayaprakash, P., Singh, B., Kothari, D. P., Chandra, A., & Al-Haddad, K. (2013). Control of reduced-rating dynamic voltage restorer with a battery energy storage system. *IEEE transactions on industry applications*, 50(2), 1295-1303.
- [12] Inci, M., Bayindir, K. Ç., & Tümay, M. (2017). The performance improvement of dynamic voltage restorer based on bidirectional dc–dc converter. *Electrical Engineering*, 99(1), 285-300.
- [13] Farhadi-Kangarlu, M., Babaei, E., & Blaabjerg, F. (2017). A comprehensive review of dynamic voltage restorers. *International Journal of Electrical Power & Energy Systems*, 92, 136-155.
- [14] Kalyan, K., Rao, M. S., & Gawre, S. (2020, February). Improvement of Power Quality Using Series Active Power Filter (SAPF). In *2020 IEEE International Students' Conference on Electrical, Electronics and Computer Science (SCEECS)* (pp. 1-5). IEEE.