

Analysis of Four Wavelength WDM Passive Optical Network Using Dispersion Compensation Fiber (DCF).

Ramavatar Singh¹ Dr Anurag Paliwal²

¹M.Tech Scholar ²Associate Professor

^{1,2}Department of Electrical Communication Engineering

^{1,2}Geetanjali Institute of Technical Studies, Udaipur, Rajasthan, India

Abstract — Wavelength division multiplexing-PON (WDM-PON) has been considered as a powerful means to meet the ever-increasing bandwidth demand by introducing multiple wavelengths and using wavelength division multiplexed multiplexer (WDM Mux)/ demultiplexer (WDM DeMux) at server end, user end and remote node (RN) to distribute wavelengths. Research in WDM-PON using multiple access techniques has been proposed after designing the transmitter these different WDM signals will be multiplexed with the help of WDM mux. Then these signals are transmitted through the optical fiber cable. To increase the range of transmission dispersion occurred in the fiber may be compensated via dispersion compensation fiber (DCF) technique.

Keywords: DCF (Dispersion Compensation Fiber), BER (Bit error rate), PON (Passive optical Network), Q factor (Quality factor), Optical line Terminal (OLT)

I. INTRODUCTION

Wavelength-division multiplexing (WDM) is a method of combining multiple laser wavelengths for transmission along optical fiber media. This method increases signal capacity in addition to allowing for bidirectional communication links over a single fiber. WDM allocates operational wavelengths to users in a systematic manner. The wavelength spacing for WDM networks can be categorized as either Coarse WDM (CWDM) with around 20 nm spacing, or dense WDM (DWDM) with less than 1 nm spacing. The key feature of a PON NETWORK is the presence of only passive components in the field, i.e. elements that operate without any electrical power. There are no amplifier or repeater elements in the field, and no need for electrical supplies

Basic architecture of WDM-PON is given below.

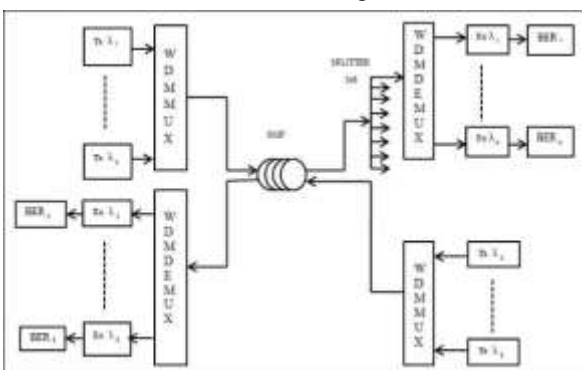

Fig. 1: WDM-PON System Architecture

The basic WDM-PON architecture is shown in figure 1.1 which consists of four PONs and these PONs are stacked by using four pairs of wavelengths $\{(\lambda_1, \lambda_5), (\lambda_2, \lambda_6), \dots, (\lambda_4, \lambda_8)\}$. All for simple network deployment and inventory management purposes

II. EVALUATION OF PON NETWORK

Passive Optical Networks square measure a family of networks (xPON), whose origin is found during an initial network that was outlined by FSAN, a gaggle of seven telecommunication operators with the aim of unifying the specifications for broadband access to households. Below is AN evolution of PON NETWORK standards since its origin.

A. APON (ATM Passive Optical Network)

It was the primary network that was outlined by FSAN (Full Service Access Network). APON NETWORK bases its broadcast downlink in bursts of cells ATM (Asynchronous Transfer Mode) with a most rate of one hundred fifty five Mbps shared between the ONT numbers that square measure connected. Its initial drawback was the limitation of one hundred fifty five Mbps that later was accumulated to 622 Mbps.

B. BPON (Broadband Passive Optical Network)

Under an equivalent normal, ITU-T G.983.x (ed. 2005), additionally came up the alleged BPON NETWORK (Broadband Passive Optical Network). It emerges as evolution of APON, given the speed limitation of an equivalent.

BPON networks are supported ATM cell broadcast, however they need the distinction respecting to APON NETWORK as a result of they'll support different broadband standards. In its initial version, BPON NETWORK networks were outlined beneath a set rate of one hundred fifty five Mbps broadcast for each transmission and downlink. However, later was amended to admit uneven channels

C. EPON (Ethernet Passive Optical Network)

Parallel to the evolution of PON, standardized by the ITU which have their origin in the FSAN, there's a completely unique specification created by the unit EFM (Ethernet within the first Mile), established by IEEE. The intention of the FSM during this sense was to require advantage of the characteristics of glass fiber technology in PON NETWORK and apply them to LAN. During this manner, they created the quality EPON NETWORK (Ethernet PON) below the rule IEEE 802.3ah (ed. 2004) that these days remains in development.

The EPON NETWORK styles relies on the transport of LAN traffic, however maintaining the characteristics of the IEEE 802.3 specification, and thus, leave aside the transfer of ATM cells, during which APON NETWORK and BPON NETWORK standards square measure based mostly and encapsulates data on LAN frames. Permits this enables this providing EPON NETWORK the subsequent benefits over APON NETWORK and BPON NETWORK standards: It allows operating on to Gbps speeds thanks to being supported

on LAN. This flow isn't single-user since it's to be shared among various operators (ONT) because the system has. Interconnection between EPON NETWORK stages is less complicated

D. GPON (Gigabit Passive Optical Network)

GPON NETWORK permits broadcast of data encapsulated in 2 technologies: ATM, simply likes within the case of the BPON NETWORK normal, however improved. LAN or TDM, victimization for that the GEM (GPON NETWORK Encapsulation Method) supported GFP (Generic Framing Procedure). GPON NETWORK provides some enhancements over all of its previous versions is accrued information measure in broadcast and offers high security.

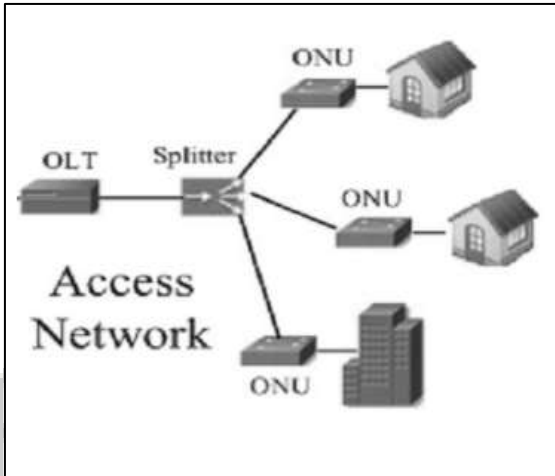

Fig. 2: 10G-GPON Network Diagram

III. C BAND WDM-PON NETWORK

In the current layout C band wavelengths from 1560nm to 1567nm are used for downstream and 1550nm to 1557 nm for upstream with 1 nm spacing in each by using WDM transmitter block. Each wavelength carries 2.5 GB/s data. Downstream data rate is 20 GB/s and upstream data rate is 20 GB/s.

Conventional Wavelength Division Multiplexed Passive Optical Network (WDM-PON) using WDM Mux/De-Mux, tunable trans-receivers etc. as shown in figure 4.1. Simulated design demonstrates 20 GB/s downstream and 20 GB/s upstream bandwidth. This system offers minimum loss budget of 21.3 dB and support 40Km link distance with 1:8 split ratio. WDM multiplexed signal at optical line terminal can be observed by spectrum analyzer as depicted in Fig. 4.2, where it can be analyzed that different multiplexed signal of wavelength 1560nm to 1567nm with 1 nm spacing with 10 dbm power each

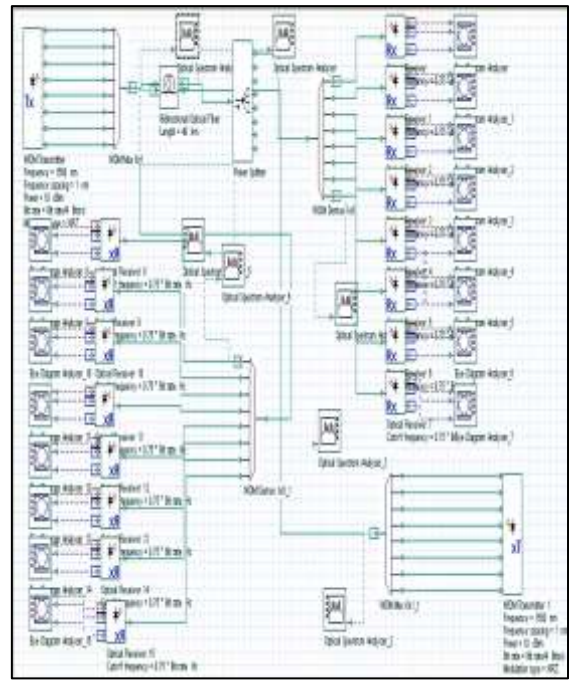

Fig. 3: Normal layout of WDM PON

IV. WDM MULTIPLEXED AND DE MULTIPLEXED RESULT

WDM multiplexed signal at optical line terminal can be observed by spectrum analyzer as depicted in Fig. 4, where it can be analyzed that different multiplexed signal of wavelength 1560nm to 1567nm with 1 nm spacing with 10 dbm power each. For this layout different spectrum at different stages are given below

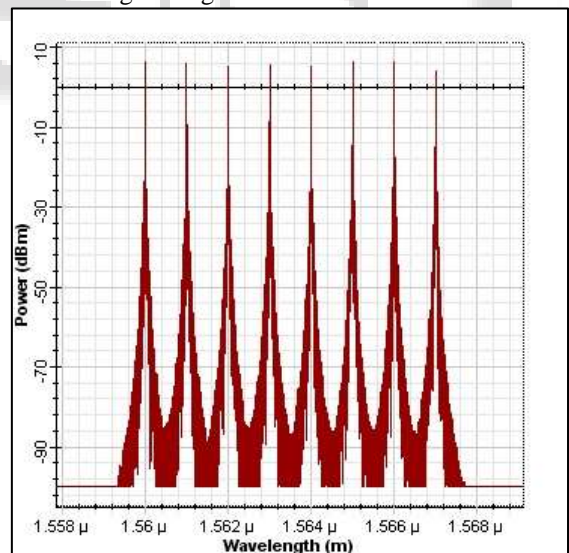

Fig. 4: Multiplexed signal at OLT

After travelling these multiplexed signal through 40km in fiber, due to attenuation and dispersion available in the fiber it lessens power of the optical signal as 0.22dB/km & 16.75 ps/nm/km respectively. Scattered optical signals can be observed using spectrum analyzer as shown in below Fig. 5. At the end of Fiber, it is terminated as the input of ONU. ONU de-multiplex the signal.

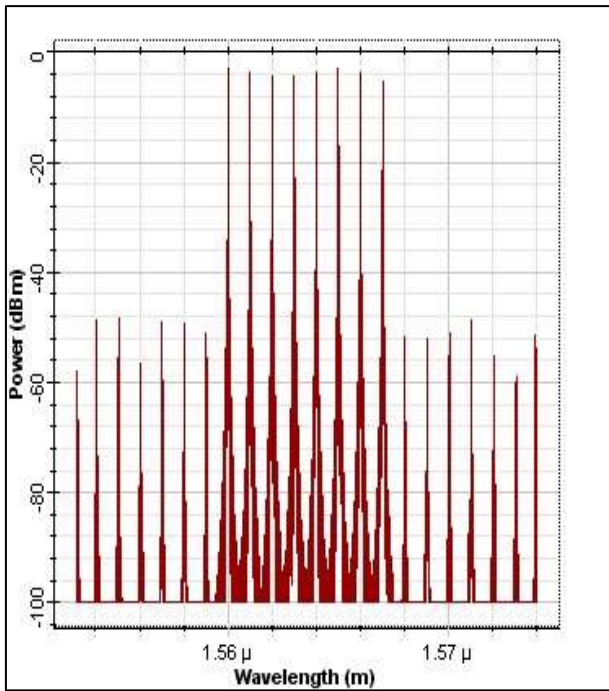

Fig. 5: Downstream optical spectrum at ONU De-Mux

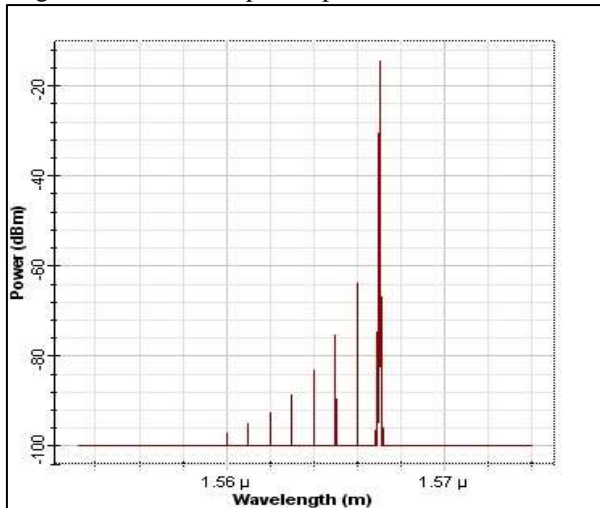

Fig. 6: De-multiplexed optical spectrum at ONU

Optical signal is then detected using PIN diode or APD and electrical signal is analyzed using eye diagram analyzer tool as shown in Fig. 7. Multiplexed signal at optical networking unit is shown in Fig. 8. Where it can be observed that multiplexed signal of wavelength 1550nm to 1557nm with 1 nm spacing. Multiplexed signal at optical networking unit is shown in Fig.9. Where I can observe multiplexed signal of wavelength 1550nm to 1557nm with 1 nm spacing. After travelling 40 km in the fiber signal is degraded and dispersed and can be observed in spectrum analyzer at the input of OLT De-Mux as shown in Fig.8. De-multiplexed signal at OLT is shown in Fig. 8.

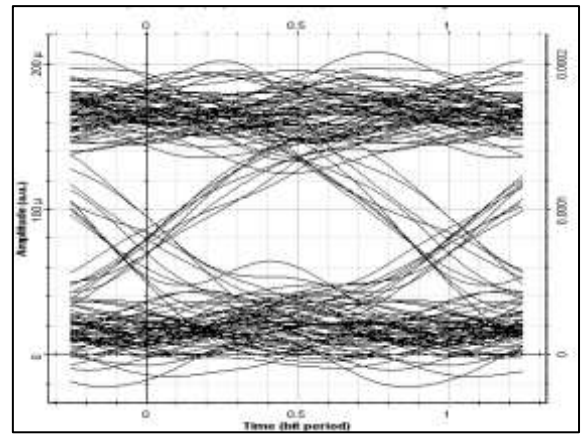

Fig. 7: Eye diagram at the ONU receiver.

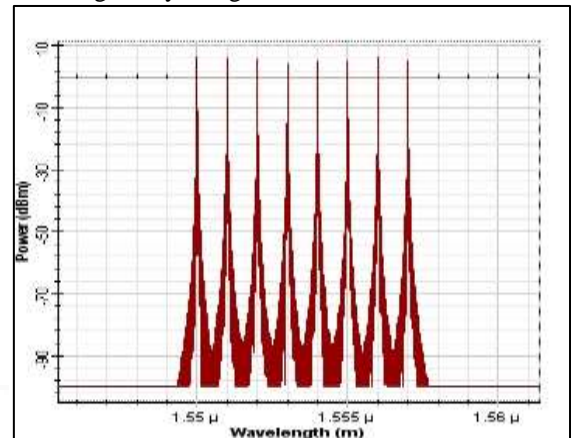

Fig. 8: Multiplexed signal at ONU

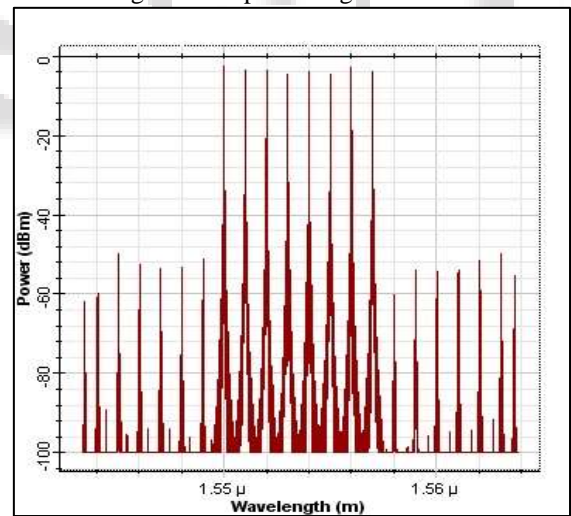

Fig. 9: Upstream optical spectrum at OLT DeMux.

V. FOUR WAVELENGTHS WDM PON ARCHITECTURE

WDM PON with 4 wavelengths is depicted below in fig 4.9. In this design due to the dispersion occurring in the system bit error at receiver is high and thus degrading the quality factor (Q) as shown in fig.10 This poor Q factor restrains the communicated data rates. To enhance the BER and Q factor of this design dispersion of the system can be minimized by dispersion compensation techniques (DCF).

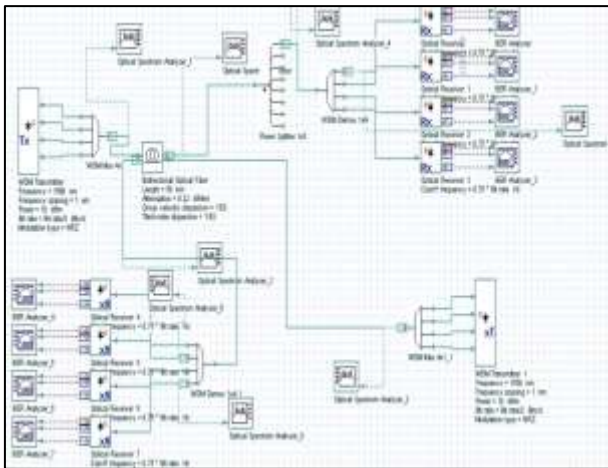

Fig. 10: Four wavelength WDM PON

VI. IMPLEMENTATION OF PROPOSED WAVELENGTH DIVISION MULTIPLEXED PASSIVE OPTICAL NETWORK WITH DISPERSION COMPENSATION FIBER (DCF)

Elementary layout of proposed Wavelength Division Multiplexed Passive Optical Network (WDM-PON) project by using WDM Mux/DeMux is depicted in Fig.4.11. In this layout already developed C band wavelengths from 1560nm to 1563nm are used for downstream and 1550nm to 1553nm for upstream with 1 nm spacing in each by using WDM transmitter block.

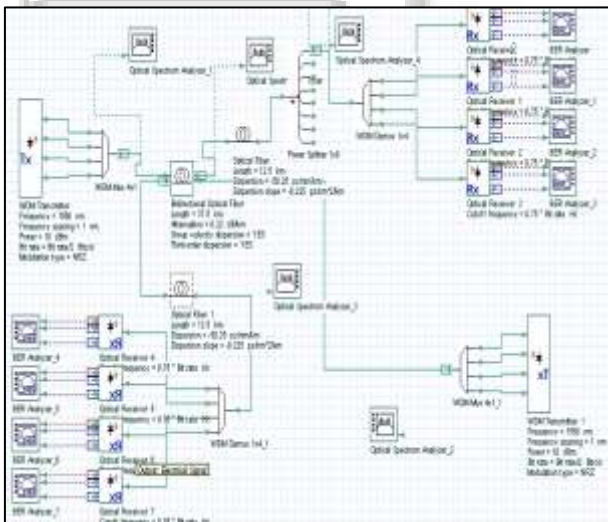

Fig. 11: four wavelengths WDM PON layout with DCF for proposed system

Each wavelength carries 5 GB/s data. Downstream data rate is 20 GB/s and upstream data rate is 20 GB/s. WDM multiplexed signal at optical line terminal can be observed by spectrum analyzer as depicted in Fig.11 where it can be analyzed that different multiplexed signal of wavelength 1560nm to 1563nm with 1 nm spacing with 10 dbm power each. For this layout different spectrum at different stages are given below.

ACKNOWLEDGEMENT

Through this paper we analyze WDM network in optical fiber communication using DCF and passive optical network and also simulate results on opti system simulation model .this

result in terms of BER and quality factor shows good efficiency of network using DCF in PON.

REFERENCES

- [1] Maier, G., Martinelli, M., Pattavina, A. and Salvadori, E. (2000). Design and cost performance of the multistage WDM-PON access networks. *J. Light. Technol.*. 18 (2): 125–143.
- [2] An, F., Kim, K. S., Gutierrez, D., Yam, S., Hu, E. S., Shrikhande, K. and Kazovsky, L. G. (2004). SUCCESS : A Next-Generation Hybrid WDM / TDM Optical Access Network Architecture. *J. Light. Technol.*. 22 (11): 2557–2569.
- [3] Banerjee, A., Park, Y., Clarke, F., Song, H., Yang, S., Kramer, G., Kim, K. and Mukherjee, B. (2005). Wavelength-division-multiplexed passive optical network (WDM-PON) technologies for broadband access: a review . *Journal of Optical Networking*. 4 (11): 737–758.
- [4] Lee, C., Sorin, W. V. and Kim, B. Y. (2006). Fiber to the Home Using a PON Infrastructure. *J. Light. Technol.*. 24 (12):4568–4583.02
- [5] Effenberger, F., Cleary, D., Haran, O., Kramer, G., Li, R. D., Oron, M. and Pfeiffer, T. 2007. An introduction to PON technologies. *IEEE Commun. Mag.*. 45 (3) :17–25.
- [6] Otaka, A. 2008. Power saving ad-hoc Report. IEEE. 1–7.
- [7] Ruffin, A. B., Downie, J. D. and Hurley, J. 2008. Purely passive long reach 10 GE-PON architecture based on duobinary signals and ultra-low loss optical fiber. *Conference on Optical Fiber Communication/National Fiber Optic Engineers Conference*. 17–19.
- [8] Effenberger, F. and El-Bawab, T. S. (2009). Passive Optical Networks (PONs): Past, present, and future. *Opt. Switch. Netw.*. 6 (3) :143–150.
- [9] Koutitas, G. and Demestichas, P. 2010. A Review of Energy Efficiency in Telecommunication Networks. *Telfor J.*. 2 (1) :2–7.
- [10] Dixit, A., Lannoo, B., Das, G., Colle, D., Pickavet, M. and Demeester, P. (2011). Flexibility Evaluation of Hybrid WDM / TDM PONs. *IEEE. International Conference on Advanced Networks and Telecommunication Systems (ANTS)*. 1–6.
- [11] Tadokoro, M., Kubo, R., Nishihara, S., Yamada, T. and Nakamura, H. (2012). Adaptive Bandwidth Aggregation Mechanisms Using a Shared Wavelength for Energy-Efficient WDM / TDM-PON. *International conference on Optical Network*. 87–88.
- [12] Andrade, D.M., Buttaboni, A., Tornatore, M., Boffi, P., Martelli, P. and Pattavina, A. (2015). Optimization of long-reach TDM/WDM passive optical networks. *Opt. Switch. Netw.*. 16 :36–45.
- [13] Kachhatiya, V. (2014). Conventional Band (C-band) Wavelength Division Multiplexed Passive Optical Network (WDM-PON). *International conferencing on communication and signal processing (IEEE)*. 377–381.
- [14] C. Bock and J. Prat, "WDM/TDM PON experiments using the AWG free spectral range periodicity to transmit

unicast and multicast data," *Optics Express* 13, 2887-2891 2005.

- [15] Kramer, G., Mukherjee, B., Pesavento, G., (2000). *Ethernet PON (ePON): Design and Analysis of an Optical Access Network*. University of California.
- [16] Lam, C. F. (2007). *Passive optical networks: principles and practice*. Elsevier Inc.

